

# OWNER'S MANUAL

## BGS-30 SELF-PROPELLED STRADDLE LIFT TRUCK



ACTUAL PRODUCT MAY NOT APPEAR EXACTLY AS SHOWN



### WARNING

Do not operate or service this product unless you have read and fully understand the entire contents of this manual. Failure to do so may result in property damage, bodily injury or death.

**BLUE GIANT**<sup>®</sup>

ISSUE DATE: MAY 1, 2017 REV.0 (PART # 038-1030E)

**TABLE OF CONTENTS**

<b>1.1 OWNER'S PURCHASE RECORD</b> .....	6	<b>6.0 TROUBLESHOOTING</b>	
<b>1.2 SAFETY PROCEDURES</b> .....	7	6.1 GENERAL .....	20
<b>2.0 INTRODUCTION</b>		6.2 CONTROLLER TROUBLESHOOTING .....	22
2.1 WARRANTY INFORMATION .....	7	6.2.1 ZAPI HANDSET .....	22
2.2 EXCLUSION OF LIABILITY .....	7	6.2.2 FAULT DETECTION .....	22
2.3 MANUFACTURER'S NOTE .....	7	6.2.2.1 GENERAL .....	22
<b>3.1 INTRODUCTION</b>		6.2.2.2 LOGBOOK ACCESS .....	22
3.2 GENERAL DESCRIPTION .....	8	6.2.3 TESTING TRUCK OPERATION .....	23
3.3 SAFETY FEATURES .....	8	6.2.4 SETTINGS AND ADJUSTMENTS .....	23
<b>4.0 OPERATION</b>		6.2.4.1 SET OPTIONS .....	23
4.2 OPERATING PRECAUTIONS .....	10	6.2.4.2 ADJUSTMENTS .....	27
4.3 BEFORE OPERATION .....	11	6.2.4.3 PARAMETER CHANGE .....	29
4.4 GENERAL CONTROL OPERATION .....	13	<b>7.0 STEERING ARM, CONTROL HEAD AND COMPARTMENT</b>	
4.5 DRIVING AND STOPPING PROCEDURES .....	13	7.1 CONTROL HEAD .....	34
4.6 BELLY-BUTTON SWITCH .....	14	7.1.1 CAP ASSEMBLY REMOVAL .....	34
4.7 STEERING ARM GAS SPRING .....	14	7.1.2 CAP ASSEMBLY INSTALLATION .....	35
4.8 LIFT AND LOWER CONTROLS .....	14	7.1.3 CONTROL HEAD REMOVAL .....	36
4.9 LOADING AND UNLOADING .....	14	7.1.4 CONTROL HEAD INSTALLATION .....	36
4.10 PARKING .....	14	7.1.5 SPEED POTENTIOMETER REPLACEMENT ...	36
<b>5.0 PLANNED MAINTENANCE</b>		7.1.6 BELLY-BUTTON SWITCH REPLACEMENT .....	36
5.1 GENERAL .....	14	7.1.7 HORN SWITCH REPLACEMENT .....	36
5.2 MONTHLY AND QUARTERLY CHECKS .....	14	7.1.8 LIFT AND LOWER SWITCH REPLACEMENT ...	36
5.3 BATTERY CARE .....	15	7.2 STEERING ARM .....	39
5.3.1 GENERAL .....	15	7.2.1 RETURN SPRING REPLACEMENT .....	39
5.3.2 SAFETY RULES .....	16	7.2.2 STEERING ARM REMOVAL .....	39
5.3.3 BATTERY CARE AND CHARGING .....	16	7.2.3 STEERING ARM INSTALLATION .....	39
5.3.4 BATTERY CLEANING .....	16	7.3 COMPARTMENT COVERS .....	39
5.3.5 MAINTENANCE FREE BATTERIES .....	16	7.3.1 REMOVAL .....	39
5.4 CHARGING BATTERIES .....	17	7.3.2 INSTALLATION .....	39
5.5 LUBRICATION .....	18	<b>8.0 BRAKE SERVICING</b>	
5.6 LIFT CHAIN MAINTENANCE .....	18	8.1 BRAKES .....	39
		8.1.1 AIR GAP ADJUSTMENT .....	39
		8.1.2 STOPPING DISTANCE ADJUSTMENT .....	40
		8.1.3 BRAKE ASSEMBLY REPLACEMENT .....	40

**9.0 TRANSMISSION, DRIVE WHEEL, LOAD WHEEL**

9.1 DRIVE WHEEL .....40  
 9.2 TRANSMISSION .....40  
 9.3 LOAD WHEEL .....41  
 9.3.1 REMOVAL .....41  
 9.3.2 LOAD WHEEL INSTALLATION .....41

**10.0 ELEVATION SYSTEM SERVICING**

10.1 GENERAL .....44  
 10.2 LIFT CHAIN LENGTH ADJUSTMENT .....44  
 10.2.1 TELESCOPIC .....44  
 10.2.2 TRIMAST FREE LIFT CHAIN .....46  
 10.2.3 TRIMAST SECONDARY LIFT CHAIN .....46  
 10.3 LIFT CHAIN WEAR INSPECTION .....48  
 10.4 LIFT CHAIN REPLACEMENT .....48  
 10.4.1 TELESCOPIC .....48  
 10.4.2 TRIMAST FREE LIFT CHAIN .....48  
 10.4.3 TRIMAST SECONDARY LIFT CHAIN .....49  
 10.5 LIFT CYLINDERS .....49

**11.0 HYDRAULIC SYSTEM SERVICING**

11.1 LINES AND FITTINGS .....50  
 11.2 HYDRAULIC PUMP, MOTOR AND RESERVOIR ASSEMBLY .....50  
 11.2.1 REMOVAL .....51  
 11.2.2 DISASSEMBLY AND REASSEMBLY .....51  
 11.2.3 INSTALLATION .....51  
 11.2.4 LIFT CYLINDER (TELESCOPIC) .....52  
 11.2.4.1 REMOVAL .....52  
 11.2.4.2 REPAIR .....52  
 11.2.4.3 INSTALLATION .....54  
 11.2.5 LIFT CYLINDER (TRIMAST FREE LIFT) .....55  
 11.2.5.1 REMOVAL .....55  
 11.2.5.2 REPAIR .....55  
 11.2.5.3 INSTALLATION .....56  
 11.2.6 LIFT CYLINDER (TRIMAST SECONDARY) ... .58

11.2.6.1 REMOVAL .....58  
 11.2.6.2 REPAIR .....58  
 11.2.6.3 INSTALLATION .....58

**12.0 ELECTRICAL COMPONENTS**

12.1 ELECTRICAL CONTROL PANEL .....60  
 12.1.1 MAINTENANCE .....60  
 12.1.2 CLEANING .....60  
 12.1.3 PANEL REMOVAL .....60  
 12.1.4 PANEL DISASSEMBLY.....60  
 12.1.5 PANEL INSTALLATION .....60  
 12.2 HORN REPLACEMENT .....60  
 12.3 PUMP MOTOR .....60  
 12.4 DRIVE MOTOR .....60  
 12.4.1 MOTOR REMOVAL .....60  
 12.4.2 MOTOR INSTALLATION .....60  
 12.5 DEADMAN SWITCH .....62

**13.0 OPTIONAL EQUIPMENT**

13.1 LOAD BACKREST .....62

**14.0 ILLUSTRATED PARTS BREAKDOWN .....64**

## LIST OF ILLUSTRATIONS

<b>FIGURE 1 NAME PLATE</b>	<b>FIGURE 12-2 CONTROL HANDLE ASSEMBLY</b> (NOT USED WHEN SIDE SHIFT)
<b>FIGURE 1-2 BGS-30 LIFT TRUCK</b>	<b>FIGURE 12-3 UPPER COVER ASSEMBLY</b> (NOT USED WHEN SIDE SHIFT)
<b>FIGURE 2-1 LOAD CENTER</b>	<b>FIGURE 12-4 EMERGENCY REVERSE SWITCH ASSEMBLY</b> (NOT USED WHEN SIDE SHIFT)
<b>FIGURE 2-2 SAMPLE OF OPERATOR CHECK LIST</b>	<b>FIGURE 12-5 CONTROL HEAD ASSEMBLY (FOR SIDE SHIFT)</b> USED UP TO SERIAL NUMBER S2315284
<b>FIGURE 2-3 FORWARD / REVERSE CONTROL</b>	<b>FIGURE 12-6 CONTROL HEAD ASSEMBLY (FOR SIDE SHIFT)</b> USED FROM SERIAL NUMBER S2315285
<b>FIGURE 2-4 PUSHBUTTON SWITCHES</b>	<b>FIGURE 12-7 TRANSMISSION, MOTOR, BRAKE ASSEMBLY</b>
<b>FIGURE 2-5 BRAKE ACTUATION</b>	<b>FIGURE 12-8 TRANSMISSION USED FROM: S2214154 ON</b> BGS-30 AND S2215045 ON BGS-40
<b>FIGURE 2-6 BELLY-BUTTON SWITCH</b>	<b>FIGURE 12-9 COMPARTMENT</b>
<b>FIGURE 3-1 LUBRICATION DIAGRAM</b>	<b>FIGURE 12-10 ADJUSTABLE STRADDLE (BGS-30 ONLY)</b>
<b>FIGURE 4-1 CONNECTING THE HANDSET</b>	<b>FIGURE 12-11 FIXED STRADDLE (BGS-40 ONLY)</b>
<b>FIGURE 4-2 ZAPI HANDSET</b>	<b>FIGURE 12-12 BATTERY COMPARTMENT</b>
<b>FIGURE 4-3 ZAPI HANDSET</b>	<b>FIGURE 12-13 WINDSHIELD (TELESCOPIC)</b>
<b>FIGURE 4-4 THROTTLE REGULATION</b>	<b>FIGURE 12-14 WINDSHIELD (TRIMAST)</b>
<b>FIGURE 4-5 ZAPI HANDSET</b>	<b>FIGURE 12-15 CASTER FOR ADJUSTABLE STRADDLE</b> (BGS-30 ONLY) - UP TO SERIAL NUMBER S2118100
<b>FIGURE 4-6 ZAPI CONTROLLER CONNECTORS</b>	<b>FIGURE 12-16 CASTER FOR ADJUSTABLE STRADDLE</b> (BGS-30 ONLY) - FROM SERIAL NUMBER S2118101
<b>FIGURE 5-1 CONTROL HEAD</b>	<b>FIGURE 12-17 CASTER FIXED STRADDLE (BGS-40 ONLY)</b>
<b>FIGURE 5-2 STEERING ARM</b>	<b>FIGURE 12-18 ELEVATION SYSTEM (TELESCOPIC)</b> USED UP TO SERIAL NUMBER S2112138
<b>FIGURE 5-3 EMERGENCY REVERSE SWITCH ASSEMBLY</b>	<b>FIGURE 12-19 ELEVATION SYSTEM (TELESCOPIC)</b> USED FROM SERIAL NUMBER S2112139
<b>FIGURE 5-4 CAP ASSEMBLY</b>	<b>FIGURE 12-20 ELEVATION SYSTEM (TRIMAST)</b> USED UP TO SERIAL NUMBER S2112138
<b>FIGURE 6-1 BRAKE ASSEMBLY</b>	<b>FIGURE 12-21 ELEVATION SYSTEM (TRIMAST)</b> USED FROM SERIAL NUMBER S2112139
<b>FIGURE 7-1 TRANSMISSION, MOTOR, BRAKE ASSEMBLY</b>	<b>FIGURE 12-22 FORK CARRIAGE (TELESCOPIC)</b>
<b>FIGURE 7-2 ADJUSTABLE STRADDLE</b>	<b>FIGURE 12-23 FORK CARRIAGE (TRIMAST)</b>
<b>FIGURE 8-1 CHAIN ASSEMBLY</b>	<b>FIGURE 12-24 SIDE SHIFT ASSEMBLY</b>
<b>FIGURE 8-2 ELEVATION SYSTEM (TELESCOPIC)</b>	<b>FIGURE 12-25 CHAIN ASSEMBLY</b>
<b>FIGURE 8-3 MAST (TRIMAST)</b>	
<b>FIGURE 9-1 HYDRAULIC SYSTEM</b>	
<b>FIGURE 9-2 MAST (TELESCOPIC)</b>	
<b>FIGURE 9-3 LIFT CYLINDER (TELESCOPIC)</b>	
<b>FIGURE 9-4 MAST (TRIMAST)</b>	
<b>FIGURE 9-5 FREE LIFT CYLINDER (TRIMAST)</b>	
<b>FIGURE 9-6 SECONDARY LIFT CYLINDER (TRIMAST)</b>	
<b>FIGURE 10-1 ELECTRICAL SYSTEM</b>	
<b>FIGURE 10-2 ELECTRICAL PANEL</b>	
<b>FIGURE 10-3 TRANSMISSION, MOTOR, BRAKE ASSEMBLY</b>	
<b>FIGURE 10-4 ELECTRICAL SYSTEM</b>	
<b>FIGURE 12-1 STEERING SYSTEM</b>	

**FIGURE 12-26 HYDRAULIC SYSTEM**

(NOT USED WHEN SIDE SHIFT OPTION)

**FIGURE 12-27 HYDRAULIC SYSTEM**

(USED WHEN SIDE SHIFT OPTION)

**FIGURE 12-28 PUMP AND MOTOR ASSEMBLY**

NOT WHEN SIDE SHIFT OPTION (USED UP TO SERIAL NUMBER S2117012)

**FIGURE 12-29 PUMP AND MOTOR ASSEMBLY**

NOT WHEN SIDE SHIFT OPTION (USED FROM SERIAL NUMBER S2117013)

**FIGURE 12-30 PUMP AND MOTOR ASSEMBLY**

(USED WHEN SIDE SHIFT OPTION ON TRUCK)

**FIGURE 12-31 HYDRAULIC SYSTEM (TELESCOPIC)**

NOT WHEN SIDE SHIFT OPTION - USED UP TO 12-14-2011

**FIGURE 12-32 HYDRAULIC SYSTEM (TELESCOPIC)**

NOT WHEN SIDE SHIFT - USED BETWEEN 12-15-2011 AND 12-26-2012

**FIGURE 12-33 HYDRAULIC SYSTEM (TELESCOPIC)**

NOT WHEN SIDE SHIFT - USED FROM 12-27-2012

**FIGURE 12-34 HYDRAULIC SYSTEM (TELESCOPIC)**

USED WHEN SIDE SHIFT OPTION

**FIGURE 12-35 HYDRAULIC SYSTEM (TRIMAST)**

NOT WHEN SIDE SHIFT OPTION - USED UP TO 12-14-2011

**FIGURE 12-36 HYDRAULIC SYSTEM (TRIMAST) NOT WHEN**

SIDE SHIFT - USED BETWEEN 12-15-2011 AND 12-26-2012

**FIGURE 12-37 HYDRAULIC SYSTEM (TRIMAST NOT WHEN**

SIDE SHIFT) - USED FROM 12-27-2012

**FIGURE 12-38 HYDRAULIC SYSTEM (TRIMAST)**

USED WHEN SIDE SHIFT OPTION

**FIGURE 12-39 LIFT CYLINDER (TELESCOPIC)**

**FIGURE 12-40 FREE LIFT CYLINDER (TRIMAST)**

**FIGURE 12-41 SECONDARY LIFT CYLINDER (TRIMAST)**

**FIGURE 12-42 ELECTRICAL SYSTEM**

USED UP TO SERIAL NUMBER S2112138

**FIGURE 12-43 ELECTRICAL SYSTEM**

USED FROM SERIAL NUMBER S2112139

**FIGURE 12-44 ELECTRICAL PANEL**

**FIGURE 12-45 DRIVE MOTOR**

**FIGURE 12-46 WIRING HARNESS**

(NOT USED WHEN SIDE SHIFT OPTION)

**FIGURE 12-47 WIRING HARNESS**

(USED WHEN SIDE SHIFT OPTION)

**FIGURE 12-48 WIRING CABLES**

**FIGURE 12-49 BATTERY PACK**

(FACTORY INSTALLED) USED UP TO S2410120

**FIGURE 12-50 BATTERY PACK (FACTORY INSTALLED)**

USED FROM SERIAL NUMBER S2410121 TO D24140007

**FIGURE 12-51 BATTERY PACK (FACTORY INSTALLED)**

USED FROM SERIAL NUMBER D24140008

**1.1 OWNER’S PURCHASE RECORD**

<b>OWNER’S PURCHASE RECORD</b> Please record information for future inquiries and to validate warranty. (See Section 2.1 for warranty validation)	
<b>Dealer:</b>	<b>Date in Service:</b>
	<b>Number of Units:</b>
<b>Owner’s Name:</b>	<b>Order Number:</b>
<b>Serial Number:</b>	<b>Year of Construction:</b>

The manufacturer offers a full line of dock levelers, dock safety equipment, accessories, ergonomic and scissor lift equipment, seals and shelters, and industrial trucks. Concurrent with a continuing product improvement program, specifications are subject to change without notice (see section 2.2 of this manual). Please contact the manufacturer for latest information. Some features illustrated may be optional in certain market areas.

**1.2 SAFETY PROCEDURES**

1. Do not operate this truck unless you have been authorized and trained to do so, and have read all warnings and instructions in Operator’s Manual and on this truck.
2. Do not operate this truck until you have checked its condition. Give special attention to tires, horn, battery, controller, lift system (including forks or attachments, chains, cables and limit switches), brakes, steering mechanism, guards and safety devices.
3. Operate truck only from designated operating position. Never place any part of your body into the mast structure or between the mast and the truck. Do not carry passengers. Keep feet clear of truck and wear foot protection.
4. Observe applicable traffic regulations. Yield right of way to pedestrians. Slow down and sound horn at cross aisles and wherever vision is obstructed.
5. Start, stop, travel, steer and brake smoothly. Slow down for turns and on uneven or slippery surfaces that could cause truck to slide or overturn. Use special care when traveling without load as the risk of overturn may be greater.
6. Travel with lifting mechanism as low as possible. Always look in direction of travel. Keep a clear view, and when load interferes with visibility, travel with load trailing.
7. Use special care when operating on ramps travel slowly, and do not angle or turn. Travel with load downhill.
8. Do not overload truck. Check nameplate for capacity and load center information.
9. When using forks, space forks as far apart as load will permit. Before lifting, be sure load is centered, forks are completely under load, and load is as far back as possible against load backrest.
10. Do not handle unstable or loosely stacked loads. Use special care when handling long, high or wide loads, to avoid losing the load, striking bystanders, or tipping the truck.
11. Do not handle loads which are higher than the load backrest or load backrest extension unless load is secured so that no part of it could fall backward.
12. Elevate forks or other lifting mechanism only to pick up or stack a load. Watch out for obstructions, especially overhead.
13. Do not lift personnel except on a securely attached specially designed work platform. **USE EXTREME CARE WHEN LIFTING PERSONNEL.** Make sure mast is vertical, place truck controls in neutral and apply brakes. Lift and lower smoothly. Remain in operating position or immediate vicinity as long as personnel are on the work platform. Never transport personnel on forks or work platform.
14. Do not allow anyone to stand or pass under load or lifting mechanism.
15. When leaving truck, neutralize travel control, fully lower lifting mechanism and set brake. When leaving truck unattended, also shut off power.

## 2.0 INTRODUCTION

The following is a quick reference to important procedures that must be followed while using the dock equipment. It is not intended to cover, or suggest that it does cover, all procedures necessary to ensure safe operation. All operators should be aware of and abide by all workplace safety regulations applicable to the operation of the dock equipment. These laws and regulations include but are not limited to:

- The Occupational Safety and Health Act (USA)
- Occupational Safety and Health Acts for Individual States (USA)
- Canadian Material Handling Regulations

For additional information on these regulations as well as industry standards that may apply to this product, please contact:

American National Standards Institute (ANSI)



1430 Broadway  
New York, NY 10018  
Telephone: (212) 642-4900

Also a member of:



Loading Dock Equipment Manufacturers  
A Product Section of Material Handling Industry of America  
A Division of Material Handling Industry  
8720 Red Oak Blvd, Suite 201  
Charlotte, NC, 28217-3992  
Telephone: (704) 676-1190

## 2.1 WARRANTY INFORMATION

Thank you for purchasing Blue Giant products. We appreciate your business, and are confident that our product will serve you for many years to come. In the event that you experience a problem with our product, our Warranty Center is here to support the Blue Giant product(s) that you have purchased.

To validate warranty on recently purchased equipment, please complete and submit your information with our online Warranty Registration at [www.bluegiant.com](http://www.bluegiant.com).

### DEALER INFORMATION

Name:

Contact:

Telephone:

For more information about Blue Giant Warranty Support, please contact your local Blue Giant Equipment dealer, representative or authorized partner near you. You may also visit [www.bluegiant.com](http://www.bluegiant.com) or phone 1.905.457.3900.

\* Note that failure to validate warranty at the time of receipt can seriously affect the outcome of any claim.

## 2.2 EXCLUSION OF LIABILITY

The manufacturer assumes no liability for damage or injury to persons or property which occur as a result of defects or faults in or incorrect use of dock equipment. The manufacturer also assumes no liability for lost profits, operating downtimes, or similar indirect losses incurred by the purchaser. Injury to third parties, irrespective of its nature, is not subject to compensation.

The manufacturer reserves the right to make changes at any time to the modules, components, and accessories, concurrent with its continuing product development program. Specifications, operating instructions, and illustrations included in this manual are subject to change without notice. Please contact manufacturer for the latest information.

## 2.3 MANUFACTURER'S NOTE

This industrial truck has been carefully inspected and tested at the manufacturer's plant prior to shipment, but should be checked upon receipt for transport damage. Any observed transport damage is to be listed on the signed copy of the freight document. Notify the freight forwarder of any damage WITHIN 48 HOURS.

### 3.1 INTRODUCTION

This publication describes the 24 volt transistor BGS-30 Self-Propelled Straddle Lift Truck distributed by Blue Giant Equipment Corporation. Included are operating instructions, planned maintenance instructions, lubrication procedures, corrective maintenance procedures and a complete parts list with part location illustrations.

Users shall comply with all requirements indicated in applicable OSHA standards and current edition of A.N.S.I. B56.1 Part II. By following these requirements and the recommendations contained in this manual, you will receive many years of dependable service from your BGS-30 lift truck.

### 3.2 GENERAL DESCRIPTION

The BGS-30 Self-Propelled Straddle Lift Truck, lifts and transports payloads up to 3,000 pounds on either rigid or adjustable forks. BGS-40 Self-Propelled Straddle Lift Truck, lifts and transports payloads up to 4,000 pounds on either rigid or adjustable forks.

The Telescopic truck has either a 104, 126 or 141 inch lift. The TRIMAST truck has either a 158, 177, or 189 inch lift. The TRIMAST fork carriage will free lift the first 4 feet without changing the overall lift height. Then the mast will start to rise. However, if the truck has an optional load backrest, the backrest will raise above the mast before the end of the full free lift.

The forward and reverse motion is controlled by either of two controller levers mounted on the control head. Stopping and turning is controlled by the steering arm. Lift and Lower is controlled by pushbuttons on the control head. The battery powered lift truck is quiet and without exhaust fumes.

The reversible AC motor propels the lift truck in forward or reverse direction throughout the available speed range. The BGS-30 lift truck can be driven with forks raised or lowered; however, the speed is restricted when the platform is raised above a preset limit.

The model number will be found on the name plate (**Figure 1-1**) along with the serial number, lifting capacity, and load center. **Figure 1-2** shows the locations of the truck's main components and controls.

### 3.3 SAFETY FEATURES

The BGS-30 is designed engineered to provide maximum safety for operator and payload. Some of the safety features incorporated into the design are:

- All control functions automatically return to "OFF" when released
- Externally accessible quick-disconnect battery plug within operator's reach
- Separately fused control circuits and power circuits
- Readily accessible horn button
- Fork carriage backrest to help stabilize the load
- Handle to provide a firm hand hold for operator
- Flow control valve regulates maximum lowering speed within prescribed limits
- Relief valve maintains hydraulic pressure within prescribed limits
- High visibility color scheme of truck provides visual alert of truck's presence
- Battery Indicator
- Casters

FIGURE 1 NAME PLATE

MODEL NO.		SERIAL NO.	
MAX CAP LB/ KG	LOAD CTR IN/ MM	LIFT HGT IN/ MM	
ALT CAP LB/ KG	LOAD CTR IN/ MM	LIFT HGT IN/ MM	
TRUCK WT LESS BATTERY LB/ KG	BATTERY MIN WT LB/ KG		
TRUCK WT WITH BATTERY LB/ KG	BATTERY MAX WT LB/ KG		
TRUCK TYPE <input type="text"/>	BATTERY TYPE <input type="text"/>	CERTIFIED <input type="text"/>	VOLTAGE <input type="text"/>
COMPLIES WITH THE APPLICABLE REQUIREMENTS OF ANSI B56.1 AND OSHA STANDARDS			



FIGURE 1-2 BGS-30 LIFT TRUCK

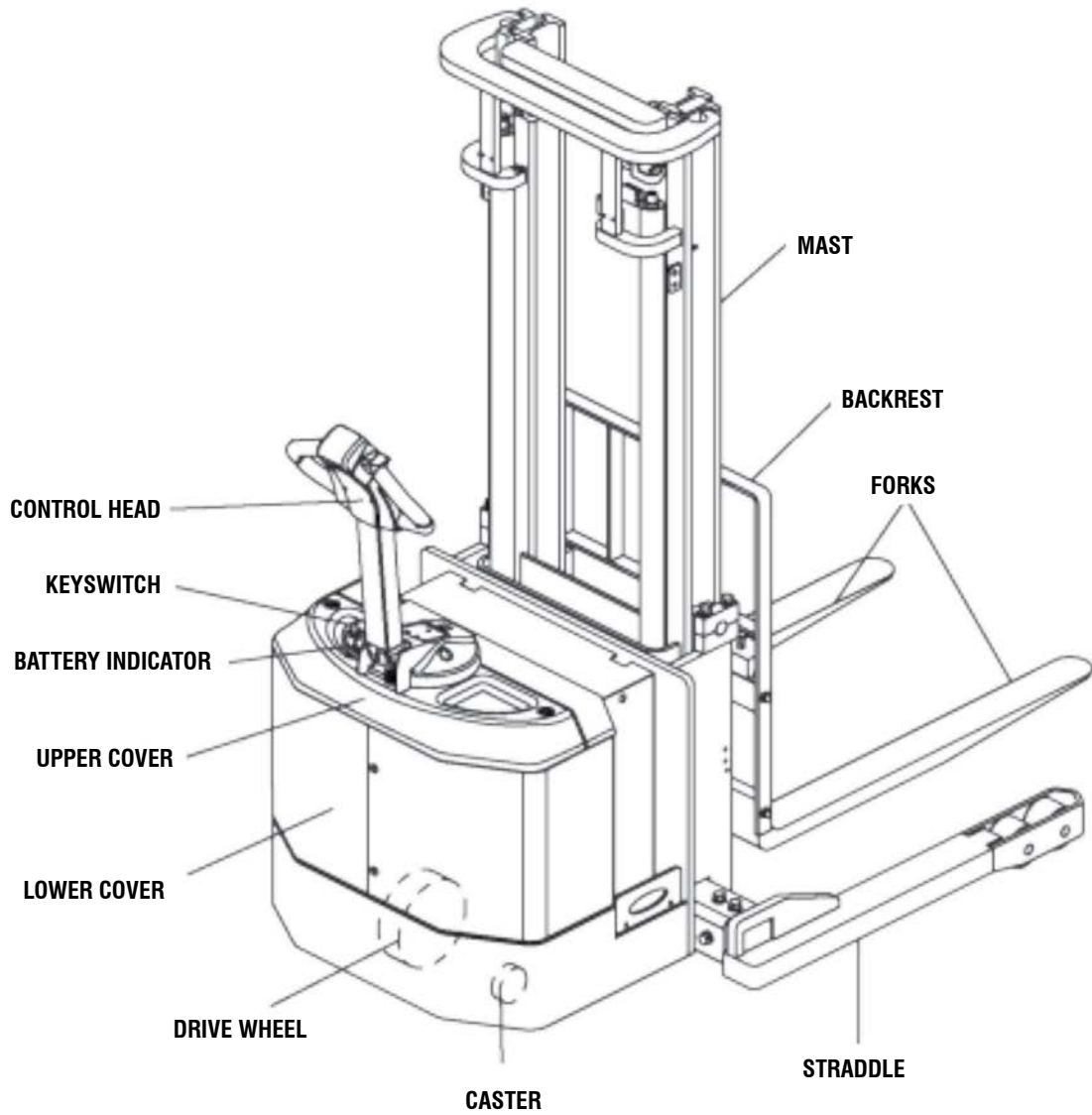

## 4.0 OPERATION

### 4.1 GENERAL

This section gives detailed operating instructions for the BGS-30 lift truck. The instructions are divided into the various phases of operations, such as operating lift, driving, and stopping. Routine precautions are included for safe operation.

### 4.2 OPERATING PRECAUTIONS

## ! WARNING

Improper operation of the lift truck may result in operator injury, or load and / or lift truck damage. Observe the following precautions when operating the BGS-30 lift truck.

The following safety precautions must be adhered to at all times:

1. Do not operate this truck unless you have been trained and authorized to do so.
2. All warnings and instructions must be read and understood before using the equipment.
3. Equipment must not be altered in any way.
4. Equipment must be inspected by a qualified person on a regular basis.
5. Do not exceed the rated capacity. Overloading may result in damage to the hydraulic system and structural components.
6. Be certain that the lifting mechanism is operating smoothly throughout its entire height, both empty and loaded.
7. Be sure that mast is vertical - do not operate on a side slope.
8. Be sure the truck has a firm and level footing.
9. Avoid overhead wires and obstructions.
10. Check for obstructions when raising or lowering the fork carriage.
11. Do not handle unstable or loosely stacked loads. Use special care when handling long, high, or wide loads to avoid tipping, loss of load, or striking bystanders.
12. Center and carry the load as far back as possible toward the fork carriage back rest. The center-of gravity of the load must not exceed the load center listed on the nameplate. See **Figure 2-1** for load center limitations.
13. Pick up loads on both forks. Do not pick up on only one fork.
14. When traveling, always lower the load as far as possible.
15. When stacking pallets in racks and it is necessary to move the load in a raised position, use caution. Operate truck smoothly.
16. Observe applicable traffic regulations. Yield right of way to pedestrians. Slow down and sound horn at cross aisles and wherever vision is obstructed.
17. Operate truck only from designated operation position. Never place any part of your body between the mast uprights. Do not carry passengers.
18. Do not allow anyone to stand or pass under load or lifting mechanism.
19. When leaving truck, neutralize travel control. Fully lower lifting mechanism and set brake. When leaving truck unattended, turn off key switch, remove key and disconnect battery.

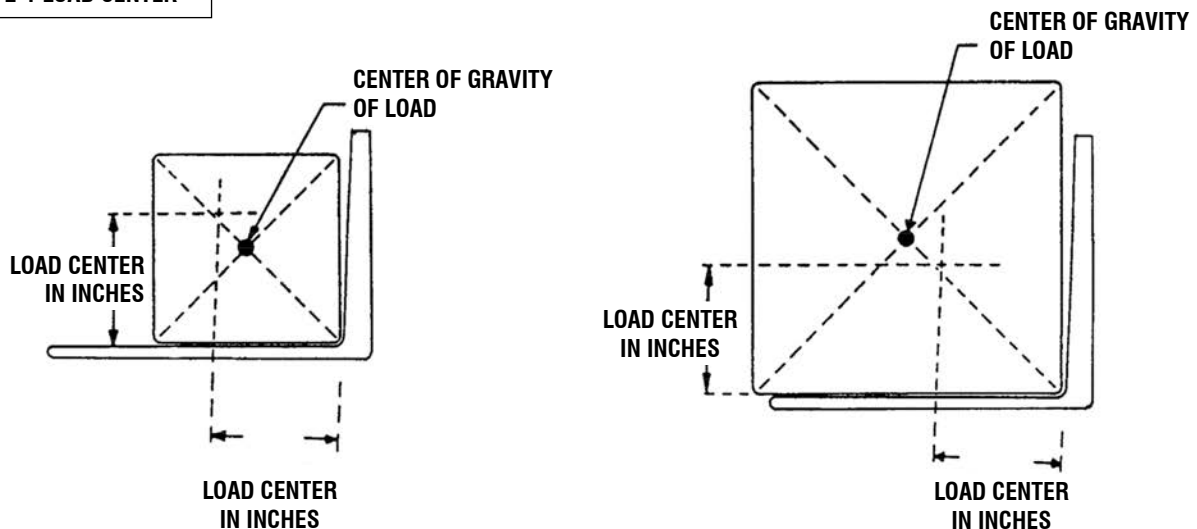

**FIGURE 2-1 LOAD CENTER**



### 4.3 BEFORE OPERATION

The BGS-30 lift truck which should be checked prior to operation. Depending on use, some trucks may require additional checks.

**Figure 2-2** shows a sample format for an Operator Checklist, which can be modified as necessary to fit your operation.

 <b>WARNING</b>
Periodic maintenance of this truck by a <b>QUALIFIED TECHNICIAN</b> is required.
 <b>CAUTION</b>
A <b>QUALIFIED SERVICE TECHNICIAN</b> should check the truck monthly for proper lubrication, proper fluid levels, brake maintenance, motor maintenance and other areas specified in the <b>SECTION 5</b> .
 <b>WARNING</b>
If the truck is found to be unsafe and in need of repair, or contributes to an unsafe condition, report it immediately to the designated authority. Do not operate it until it has been restored to a safe operating condition. Do not make any unauthorized repairs or adjustments. All service must be performed by a qualified maintenance technician.

**TABLE 2-1 OPERATOR CHECKS**

ITEM	DESCRIPTION
Transmission and Hydraulic Systems	Check for signs of fluid leakage.
Forks	Check for cracks and damage; and, that they are properly secured.
Chains, Cables and Hoses	Check that they are in place, secured correctly, functioning properly and free of binding or damage.
Guards and Load Backrest	Check that safety guards are in place, properly secured and not damaged.
Safety Signs	Check that warning labels, nameplate, etc., are in good condition and legible.
Horn	Check that horn sounds when operated.
Steering	Check for binding or looseness in steering arm when steering.
Travel Controls	Check that speed controls on control head operate in all speed ranges in forward and reverse and that belly button switch functions.
Wheels	Check drive wheel for cracks or damage. Move truck to check load for freedom of rotation.
Hydraulic Controls	Check operation of lift and lower to their maximum positions.
Brakes	Check that brakes actuate when steering arm is raised to upright position, and when lowered to horizontal position.
Deadman / Parking Brake	Check that steering arm raises to upright position when released and brake applies.
Battery Disconnect	Check that battery can be disconnected and reconnected. Check for connector damage.
Battery Charge	Check the battery indicator.
High Speed Limit Switch	Allow for enough space to operate truck in high speed. Elevate forks approximately two feet, then test drive truck to check if high speed is cut out.

**FIGURE 2-2 SAMPLE OF OPERATOR CHECK LIST**

***BLUE GIANT***<sup>®</sup>

**Electric Truck  
Daily Operator Check List**

DATE: \_\_\_\_\_ OPERATOR: \_\_\_\_\_

VEHICLE NUMBER: \_\_\_\_\_ MODEL NUMBER: \_\_\_\_\_

DEPARTMENT: \_\_\_\_\_ SHIFT: \_\_\_\_\_

CHECK	O.K. ✓	NEED MAINTENANCE
Load Wheels		
Horn		
Lift - Lower Control		
Attachment Operation		
Forward and Reverse Controls		
Steering		
Brakes		
Hydraulic Leaks, Cylinders, Valves, Hoses, etc.		

April 1, 2017

#### 4.4 GENERAL CONTROL OPERATION

The speed control (See **Figure 2-3**) located on each side of the control head provides fingertip control for driving the truck. Rotate the control in the direction you want to travel. The farther you rotate the control from the neutral position, the faster the truck will travel.

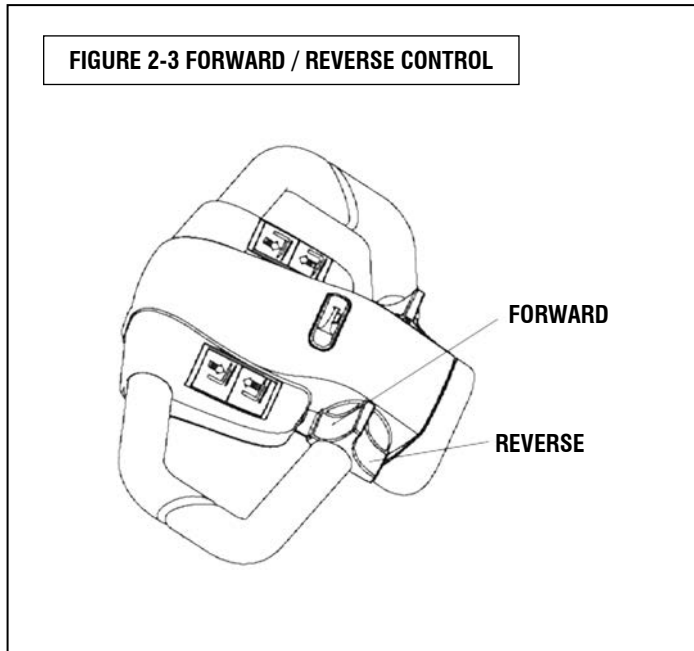

The pushbutton switches (See **Figure 2-4**), located on the front of the control head activate the lift-lower controls and the horn.

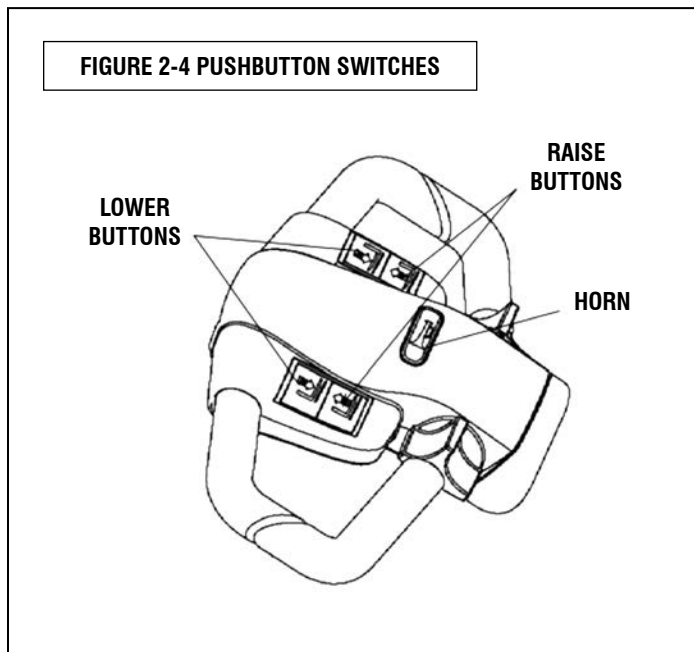

The brake is fully applied by lowering or raising the steering arm. (See **Figure 2-5**) All traction control power is shut off when the brake is engaged. When the steering arm is in the upright position, the brake acts as a parking brake. Deadman braking occurs when the handle is released and spring action raises steering arm to the upright position.

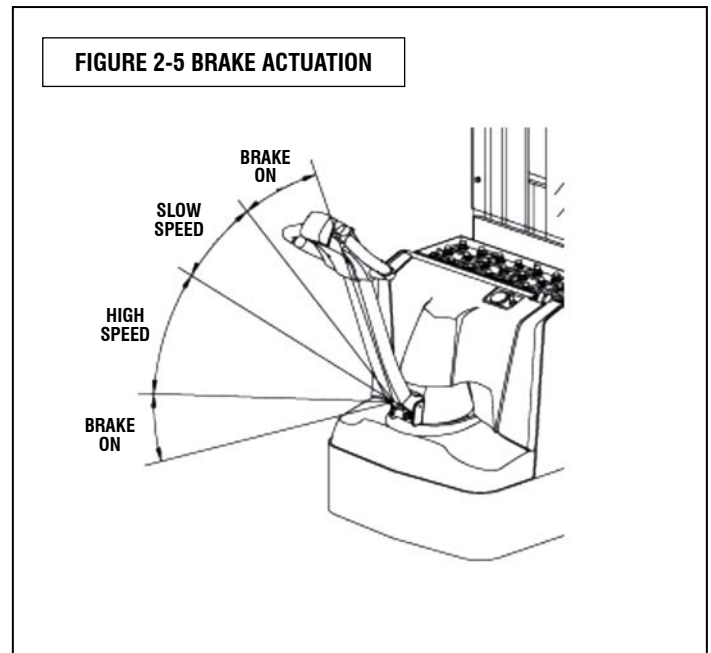

#### 4.5 DRIVING AND STOPPING PROCEDURES

1. Connect the batteries and turn on the key switch. Grasp the grips of the steering head so that the speed control can be comfortably operated by either thumb.
2. Lower the steering arm to a comfortable position above horizontal to disengage the brake and to energize the electrical circuits. If the truck is not moved, the electrical circuits will time out and will de-energize. See **Figure 2-5**.
3. To move forward (with load in front), slowly press the speed control forward. See **Figure 2-3**. Press the forward speed control farther to increase speed.
4. To slow down or stop, release the speed control and lower or raise the steering arm to the horizontal or vertical position. See **Figure 2-5**. In those positions, the brake engages, slowing or stopping the truck.
5. Procedures for movement in reverse are the same as in the forward direction except slowly press the speed control backward. See **Figure 2-3**.

## 4.6 BELLY-BUTTON SWITCH

The belly-button switch (**Figure 2-6**) minimizes the possibility of the driver being pinned by the steering arm while driving the lift truck in slow speed. If the switch presses against the operator while the lift truck is being driven toward the operator, the switch changes the direction of the lift truck.

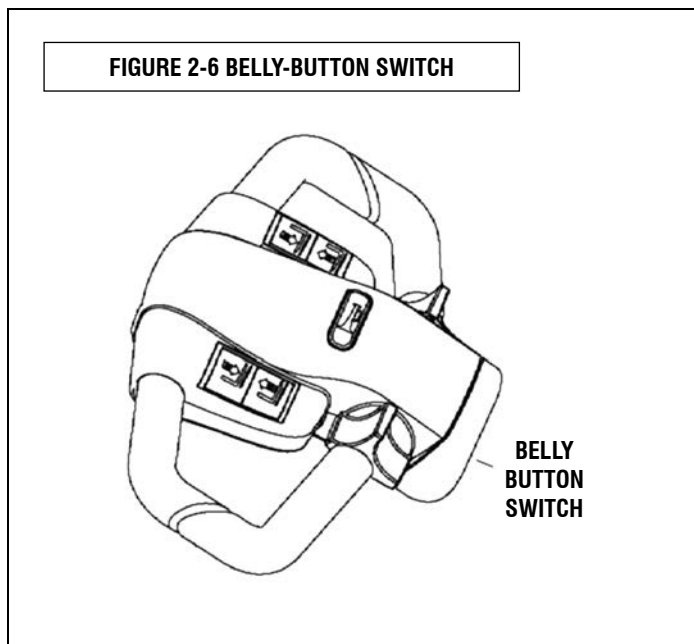

## 4.7 STEERING ARM GAS SPRING

The steering arm gas spring automatically raises the steering arm to the upright position when the steering arm is released. If the steering arm does not return fully, the steering arm gas spring requires replacement. Return truck to maintenance for repair.

## 4.8 LIFT AND LOWER CONTROLS

Lift / Lower Control buttons are located on the steering control head. (**Figure 2-4**) To lift forks, push in either LIFT button and hold until forks reach desired height. To lower forks, push in either LOWER button and hold until forks descend to desired height.

## 4.9 LOADING AND UNLOADING

1. Move truck to location where load is to be picked up.
2. Move the truck into position so forks are within pallet or skid, and the load is centered over the forks and as far back as possible.
3. Raise forks to lift load.
4. Drive to area where load is to be placed.
5. Move truck to align load with its new position.
6. Lower the load until it rests squarely in place and the forks are free.
7. Slowly move the truck out from under the load.

## 4.10 PARKING

When finished with moving loads, return the truck to its maintenance or storage area. Turn off the key switch and disconnect the batteries. Charge batteries as necessary. Refer to battery care instructions.

## 5.0 PLANNED MAINTENANCE

### 5.1 GENERAL

Planned maintenance consists of periodic visual and operational checks, parts inspection, lubrication, and scheduled maintenance designed to prevent or discover malfunctions and defective parts. The operator performs the checks in SECTION 4, , and refers any required servicing to a qualified maintenance technician who performs the scheduled maintenance and any required servicing.

### 5.2 MONTHLY AND QUARTERLY CHECKS

**Table 3-1** is a monthly and quarterly inspection and service chart based on normal usage of equipment eight hours per day, five days per week. If the lift truck is used in excess of forty hours per week, the frequency of inspection and service should be increased accordingly. These procedures must be performed by a qualified service technician or your Blue Giant Service Representative.

## 5.3 BATTERY CARE

### 5.3.1 GENERAL

The BGS-30 may be equipped with maintenance free or industrial wet cell batteries. The care and maintenance of the battery is very important to obtain efficient truck operation and maximum battery life.

#### CAUTION

Gases produced by a battery can be explosive. Do not smoke, use an open flame, create an arc or sparks in the vicinity of the battery. Ventilate an enclosed area well when charging.

#### CAUTION

Batteries contain sulfuric acid which may cause severe burns. Avoid contact with eyes, skin or clothing. In case of contact, flush immediately and thoroughly with clean water. Obtain medical attention when eyes are affected. A baking soda solution (one pound to one gallon of water) applied to spilled acid until bubbling stops, neutralizes the acid for safe handling and disposal.

Leakage voltage from battery terminals to battery case can cause misleading trouble symptoms with the truck electrical system. Since components of the truck electrical system are insulated from truck frame, leakage voltage will not normally affect truck operation unless a short circuit or breakdown of circuit wire insulation to truck frame occurs.

A voltage check from battery connector terminal to battery case should indicate near zero volts. Typically, however, the sum of the voltages at both terminals will equal battery volts. This leakage voltage will discharge the battery. As battery cleanliness deteriorates, the usable charge of the battery decreases due to this self discharge.

Although a leakage voltage reading of zero volts may not be possible, a cleaner battery will have more usable charge for truck operation and not affect operation of electronic devices on the unit.

**TABLE 3-1 MONTHLY AND QUARTERLY INSPECTION AND SERVICE CHART**

INTERVAL	VISUAL CHECKS - INSPECTION OR SERVICE
Monthly	Check mechanical brake for proper operation
Monthly	Check load wheels for wear. A poly load wheel must be replaced if worn to within 1/16 inch of hub. Check for separation from hub
Monthly	Check drive wheel for wear. A poly drive wheel must be replaced if worn to within 3/4 inch of hub. Check for separation from hub
Monthly	Inspect wiring for loose connections and damaged insulation
Monthly	Inspect contactors for proper operation
Monthly	Check deadman brake switch for proper operation
Monthly	check lift chain tension, lubrication and operation (see paragraph 5-6.)
Quarterly	Check lift cylinder for leakage
Quarterly	Check for excessive jerking of steering arm when stopping or starting
Semi-annually	Inspect for chain wear (See SECTION 10)

### 5.3.2 SAFETY RULES

- Wear protective clothing, such as rubber apron, gloves, boots and goggles when performing any maintenance on batteries. Do not allow electrolyte to come in contact with eyes, skin, clothing or floor. If electrolyte comes in contact with eyes, flush immediately and thoroughly with clean water. Obtain medical attention immediately. Should electrolyte be spilled on skin, rinse promptly with clean water and wash with soap. A baking soda solution (one pound to one gallon of water) will neutralize acid spilled on clothing, floor or any other surface. Apply solution until bubbling stops and rinse with clean water.
- If truck is equipped with wet cell batteries, keep vent plugs firmly in place at all times except when adding water or taking hydrometer readings. Do not allow dirt, cleaning solution or other foreign material to enter cells. Impurities in electrolyte has a neutralizing effect reducing available charge.
- Do not bring any type of flame, spark, etc., near the battery. Gas formed while the battery is charging, is highly explosive. This gas remains in cell long after charging has stopped.
- Do not lay metallic or conductive objects on battery. Arcing will result.
- Do not touch non-insulated parts of DC output connector or battery terminals to avoid possible electrical shock.
- De-energize all AC and DC power connections before servicing battery.
- Do not charge a frozen battery.
- Do not use charger if it has been dropped or otherwise damaged.

### 5.3.3 BATTERY CARE AND CHARGING



Never smoke or bring open flame near the battery. Gas formed during charging is highly explosive and can cause serious injury.

1. Charge the battery only in areas designated for that use.
2. Make certain the charger being used matches the voltage and amperage of the truck battery.
3. Before disconnecting or connecting batteries to a charger, make sure the charger is "OFF". If an attempt is made to do this while the charger is "ON", serious injury to you, the battery and the charger could result.
4. Before connecting the battery cable to the trucks receptacle, make sure the key switch is off. The battery cable must be fully connected before the truck is used. If the plug is not making good contact, heat will weld the two parts of the battery connector together, making it difficult to remove and necessary to replace.
5. Battery terminals should be checked and cleaned of corrosion regularly. Good battery terminal contact is essential not only for operation, but also for proper charging of the battery.
6. The charging requirements will vary depending on the use of the truck. The battery should be given as equalizing charge on a weekly basis. This charge should normally be an additional three hours at the finish rate.
7. Make certain battery used meets weight and size requirements of truck. NEVER operate truck with an undersized battery.

### 5.3.4 BATTERY CLEANING

For more information please see Battery Manufacturers Recommendations

### 5.3.5 MAINTENANCE FREE BATTERIES

Some trucks may be equipped with maintenance free batteries. These batteries are completely sealed, will not require any watering and have a full 80% discharge available.

Sealed Maintenance Free batteries contain a pressure release valve and under normal operating conditions do not require any special ventilation.



## ⚠ CAUTION

Do not try to open this battery or remove the pressure release valve.

Only under severe overcharging, such as connected to an improperly sized charger, will any significant amount of gasses be released from the battery. Also, being a valve regulated battery, it never requires watering.

### 5.4 CHARGING BATTERIES

Charging requirements will vary depending on depth of discharge and temperature. Follow safety rules when placing a battery on charge. Proceed as follows:

1. Park truck at charging station with carriage lowered and turn the key switch off.
2. Check the condition of the AC cord, the battery connector and battery cables. If there are any cuts in the cable, any exposed wires, loose plugs or connectors, DO NOT attempt to charge the batteries. Contact appropriate personnel for repairs to be made.
3. Disconnect the batteries from the truck and connect the batteries to the charger. Make sure connectors are mated properly.
4. Connect the charger to the appropriate power supply.
5. Follow the instructions for the charger being used.

BATTERY HAZARD	⚠ DANGER
	<p><b>EXPLOSIVE/POISON/CAUSTIC</b>  <b>NO SPARKS, FLAMES, SMOKING</b>  <b>BATTERY ACID</b> can cause blindness  and severe burns  <b>SHIELD EYES, AVOID SKIN CONTACT</b>  <b>IF SPLASHED</b> flush immediatly with water,  get medical help fast.</p> <p>Do not service battery while on charge.  Do not connect or disconnect battery from  charger while charger is on.</p> <p>Only qualified and experienced personnel should  perform maintenance and repair on batteries.</p> <p>Use caution while servicing or removing battery.  (Refer to Battery Safety Sheet).</p>

## 5.5 LUBRICATION

Refer to **Table 3-2** for the recommended types of grease and oil. **Table 3-3** in conjunction with **Figure 3-1** identifies the items requiring lubrication.

## 5.6 LIFT CHAIN MAINTENANCE

Fully raise and lower fork carriage while observing chains as they move over chain sheaves. Ensure chain is aligned and tracking properly and all links are pivoting freely. With fork carriage fully lowered, spray or brush on a film of SAE 30 or 40 engine oil.

**TABLE 3-2 RECOMMENDED LUBRICANTS  
SEE TABLE 3-3 FOR APPLICATION**

No. 1	Transmission oil—EP SAE 80W-90
	Transmission oil—EP SAE 10W-30 (Note)
No. 2	Grease—Lithium base, general purpose.
No. 3	Hydraulic oil-Heavy duty with a viscosity of 150 SUS foam suppressing agent and rust and oxidation inhibitors
	Hydraulic oil-Heavy duty with a viscosity of 100 SUS foam suppressing agent and rust and oxidation inhibitors (Note)
No. 4	SAE 30 or 40 Engine lubricating oil

**NOTE:** Used on cold conditioned trucks.

**TABLE 3-3 LUBRICATION CHART**

FIG 3-2 INDEX NO.	LOCATION	METHOD OF APPLICATION	TYPE (TABLE 3-2)	APPLICATION OF LUBRICANT
1	Inner and Outer Mast	Brush	No. 2	Full length of channel where rollers operate
2	Lift Chain	Brush or Spray	No. 4	See Paragraph 5-6
3	Fork Carriage	Brush	No. 2	Light coating where forks slide
4	Hydraulic Reservoir	Can	No. 3	With fork carriage fully lowered, fill reservoir with hydraulic oil to 1 inch below opening
5	Pivot Bearing Fitting	Gun	No. 2	Pressure lubricate
6	Transmission Capacity	Can	No. 1	Fill to level plug opening

FIGURE 3-1: LUBRICATION DIAGRAM

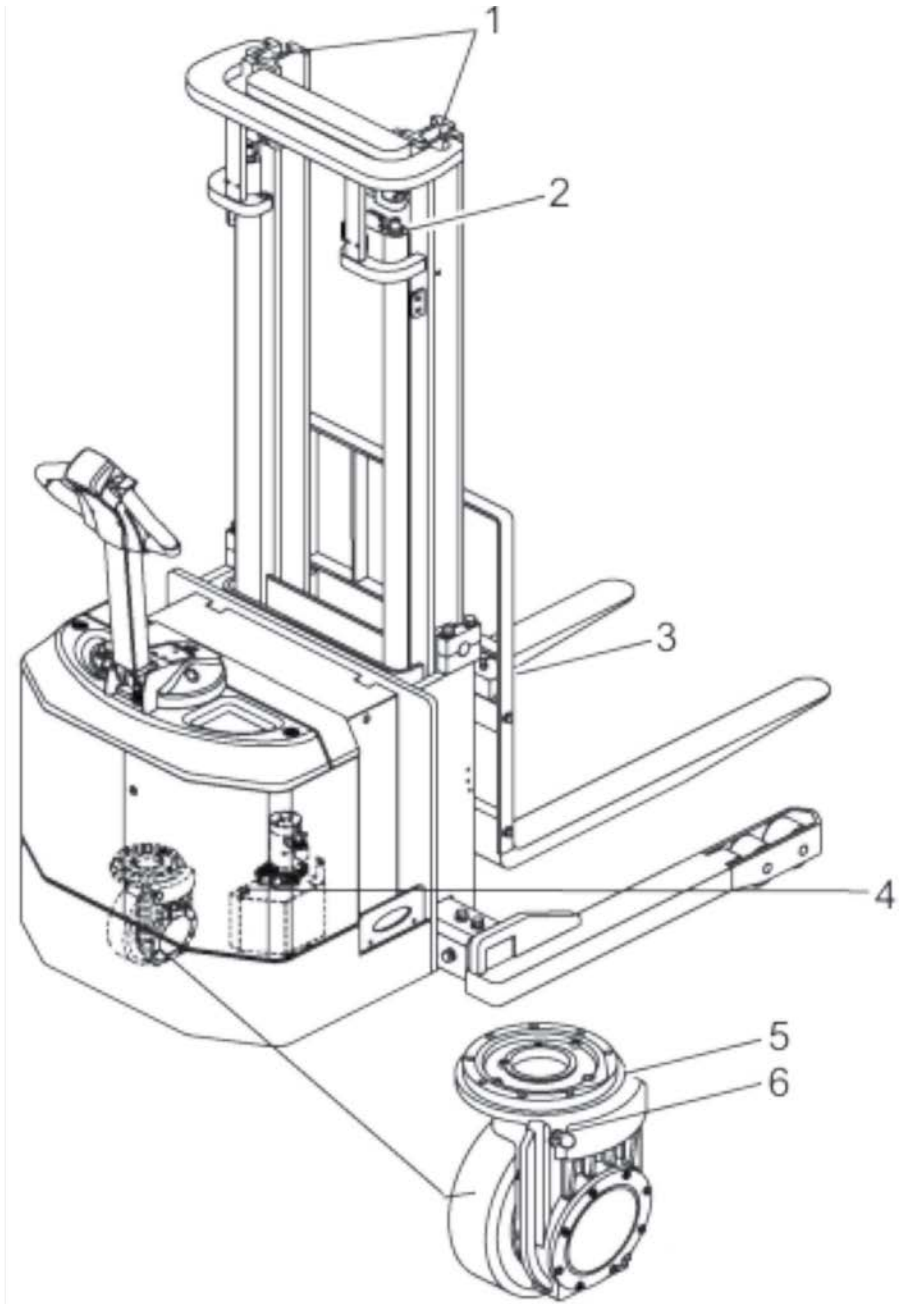

## 6.0 TROUBLESHOOTING

### 6.1 GENERAL

Use **Table 4-1** as a guide to determine possible causes of trouble. The table is divided into five main categories: Truck and Hydraulic System Will Not Operate; Truck Does Not Operate Forward or Reverse; Trouble With Braking; Trouble With Lifting Or Lowering, and Miscellaneous malfunctions.

**TABLE 4-1 TROUBLESHOOTING CHART**

MALFUNCTION	PROBABLE CAUSE	CORRECTIVE ACTION
<b>TRUCK AND HYDRAULIC SYSTEM WILL NOT OPERATE</b>  Truck will not travel nor will lift system operate	a. Fuse blown	Check fuse and replace if necessary
	b. Battery dead or disconnected	Check battery quick-disconnect plug and check battery voltage
	c. Keyswitch defective	Bypass keyswitch to determine if it is malfunctioning
	d. Defective wiring	Check for open circuit. Repair as required
<b>TRUCK DOES NOT OPERATE FORWARD OR REVERSE</b>  Truck does not travel forward or reverse All other functions operate normally	a. Check all wiring. A loose connection may be the cause of malfunction	Tighten all loose connections before further troubleshooting
	b. Defective dead man switch	Check and replace switch if defective
	c. Defective main contactor	Check for proper operation and replace if necessary
	d. Defective potentiometer	Check and replace potentiometer if defective
<b>TRUCK TRAVELS FORWARD BUT NOT IN REVERSE</b>  <b>TRUCK TRAVELS REVERSE BUT NOT IN FORWARD</b>  <b>TRUCK TRAVELS FORWARD AND IN REVERSE AT LOWER SPEEDS; WILL NOT TRAVEL AT HIGH SPEED</b>	Defective potentiometer in control head	Check and replace potentiometer if defective
<b>TROUBLE WITH BRAKING</b> Truck does not slow with brake, or brake does not engage	a. Defective dead man switch	Check deadman switch for continuity. If none found when the control arm is in the brake position, replace switch
	b. Defective electric brake	Adjust or replace brake
Brake will not release	a. Air gap more than 0.01 in (0.25mm)	Adjust
	b. Brake temperature above 281 F (140 C)	Allow to cool and check air gap
	b. Open brake circuitry or wiring	Make voltage checks
Brake drags	b. Air gap less than 0.01 in (0.25mm).	Adjust
	b. Defective electric brake	Replace
Brake grabs	a. Incorrect stopping distance adjustment.	Adjust
	b. Defective electric brake	Replace
Abnormal noise and chatter when brake is applied	Defective electric brake	Replace

TABLE 4-1 TROUBLESHOOTING CHART (continued)

MALFUNCTION	PROBABLE CAUSE	CORRECTIVE ACTION
<b>TROUBLE WITH LIFTING OR LOWERING</b> Oil sprays or flows from the top of the lift cylinder.	Defective packing in lift cylinder	Repair lift cylinder
Squealing sounds when lifting forks	a. Oil level too low	Identify oil leak
	b. Dry channels in mast	Apply grease
	c. Defective mast or carriage rollers	Replace rollers
Forks do not lift to top	a. Oil level too low	Add oil to reservoir
	b. Load larger than capacity	Refer to I.D. plate for capacity
Weak, slow or uneven action of hydraulic system	a. Defective pump or relief valve (0.25mm)	Check pressure. Adjust as necessary
	b. Worn lift cylinder	Replace cylinder
	c. Load larger than capacity (0.25mm)	Refer to I.D. plate for capacity
	d. Defective lift motor solenoid	Replace relay on pump motor
	e. Battery charge low	Charge battery
Forks do not lift, pump motor does not run	a. Battery is dead or disconnected adjustment	Check and recharge if required
	b. Defective wiring	Check and repair as required
	c. Defect in electrical system for operating pump motor	Check lift switch in control head, as well as the relay
Forks do not lift, motor runs	Defect in hydraulic system	Check the oil level in the reservoir and the oil lines to the lift cylinder, and repair as required. If normal, check the hydraulic pump, and relief valve. Repair, or adjust
Forks lift, but will not go down		Check lowering control switch in control head and lowering solenoid on valve assembly. Replace as required
Load will not hold	a. Oil bypassing internally in control valve	Replace valve assembly
	b. Worn lift cylinder or packing	Repack cylinder
Platform does not lift to top. Pump motor runs	a. Oil level too low	Add oil to reservoir
	b. Load larger than capacity	Refer to nameplate on side of mast for maximum load capacity.
	c. Batteries need charging	Change batteries
Forks creep downward under load when in a raised position	Leak in hydraulic system, lift cylinder or lowering valve	Check for leaking fitting in hydraulic line and repair as required. Repack lift cylinder or replace valve assembly

**TABLE 4-1 TROUBLESHOOTING CHART (continued)**

MALFUNCTION	PROBABLE CAUSE	CORRECTIVE ACTION
<b>MISCELLANEOUS</b> Steering arm does not return to the upright position	a. Weak return spring	Replace spring
	b. Binding	Check and free the binding item. Verify that the cable has not been damaged. Repair or replace as needed
Truck moves forward when arm is pulled down	a. Belly-button switch defective	Check for short, and repair or replace as necessary
	b. Short in control head	Check wiring and repair as required
Steering arm jerks excessively starting or stopping the truck	Drive wheel worn	Replace drive wheel if worn to within 3/4 inch of hub
Drive motor is jerky	Motor internally damaged or worn	Replace motor

## 6.2 CONTROLLER TROUBLESHOOTING

### 6.2.1 ZAPI HANDSET

A Zapi Handset is available that is designed specifically for use with the Zapi controller. It serves multiple functions of reading diagnostic data, testing truck operation, setting options, adjustments and parameter changes of the controller. The Zapi Handset is available through your Blue Giant dealer. If you require dealer location information, contact Blue Giant.

Remove the rubber plug from the CNC connector of the controller and plug in the Zapi Handset connector as shown in **Figure 4-1**.



**FIGURE 4-1 CONNECTING THE HANDSET**

### 6.2.2 FAULT DETECTION

#### 6.2.2.1 GENERAL

The controller provides diagnostics information to assist technicians in troubleshooting problems. When a fault is detected, an alarm is recorded in the logbook. It has a FIFO (First Input First Output) structure that means the oldest alarm is lost when the database is full and a new alarm occurs. The logbook is composed of alarms with the following information:

- The alarm code
- The times that each alarm occurs consecutively
- The Hour Meter value when the latest event of every alarm occurred
- The invert temperature when the latest event of every alarm occurred. This function permits a deeper diagnosis of problems as the recent history can be revisited.

#### 6.2.2.2 LOGBOOK ACCESS

To view the alarm logbook proceed as follows:

1. Connect the Zapi Handset, refer to paragraph 6-2.1.
2. Press the ROLL down button (1, **Figure 4-2**) and the ENTER button (3) at the same time to enter the MAIN MENU.
3. Press the ROLL down button (2) or the ROLL up button (1) to find the ALARMS display.
4. Press the ENTER button (3) to view the alarms.
5. Press the OUT button (6) to exit the alarms.

**NOTE:** Refer to [www.bluegiant.com](http://www.bluegiant.com) for the Zapi supplement containing detailed information on alarm codes. There are two versions shown. The BGS-25 uses the Standard version which lists the error by: Alarm Name, Repetitions, Temperature and Hour Meter reading.

## 6.2.3 TESTING TRUCK OPERATION

The Zapi Handset can be used to test certain truck operations as follows:

1. Connect the Zapi Handset, refer to paragraph 6-2.1.
2. Press the ROLL down button (1, **Figure 4-2**) and the ENTER button (3) at the same time to enter the MAIN MENU.
3. Press the ROLL down button (2) or the ROLL up button (1) to find the TESTER display.
4. Press the ENTER button (3) to view the tests.
5. To verify various switch functions, locate the switch on the display and then operate that function to verify operation.
6. Press the OUT button (6) to exit the tests.

## 6.2.4 SETTINGS AND ADJUSTMENTS

### 6.2.4.1 SET OPTIONS

To set options proceed as follows and refer to **Table 4-2**:

1. Connect the Zapi Handset, refer to paragraph 6-2.1.
2. Press the ROLL up button (1, **Figure 4-2**) and the SET up button (5) at the same time to enter the CONFIG MENU.
3. Press the ROLL down button (1) or the ROLL up button (2) to find the SET OPTIONS display.
4. Press the ENTER button (3) to view the options.
5. Press the ROLL down (2) or the ROLL up button (1) to find the option to be changed.
6. Press the SET up button (5) or the SET down button (6) until the desired value setting is reached. The option is now set at the desired value.
7. Press the OUT button (4) to exit the options.

**FIGURE 4-2 ZAPI HANDSET**

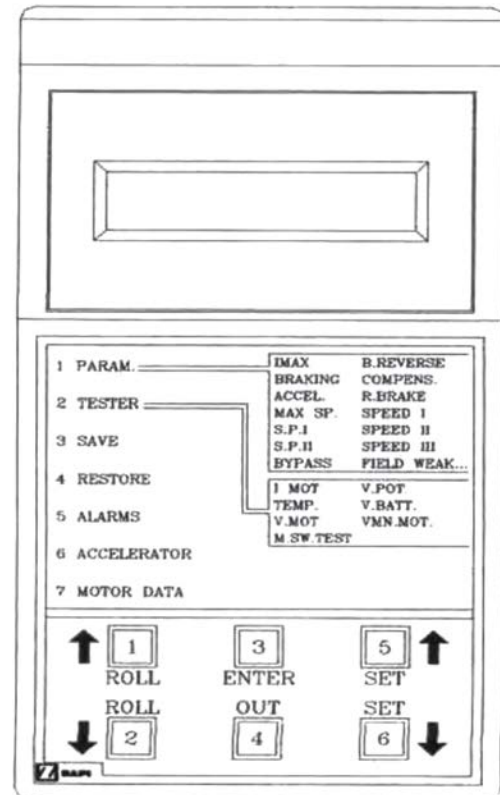

TABLE 4-2 SET OPTIONS

PARAMETER	FACTORY SETTING	DESCRIPTION
TILLER switch	HANDLE	This option handles the input CNB #3 (Table 4-5). This input opens when the operator leaves the truck (released). It is connected to a keyswitch controlled voltage when the operator is present.
SET INPUT #1	OPTION #1	<p><b>Standard Version only</b> This option handles the digital input CNA #15. It can be can be set as:</p> <ul style="list-style-type: none"> <li>OPTION #1: CNA is managed as a cutback speed input (SR #1).</li> <li>OPTION #2: CNA is managed as a digital handbrake input.</li> <li>OPTION #3: CNA is managed as an inching backward.</li> </ul> <p>The input CNA #15 (Table 4-5) can only be used as Aux Lowering request when the MDIPRC is PRESENT.</p> <p>This input must be connected to a keyswitch controlled voltage. The SR #1 becomes active when CNA #15 (Table 4-5) is open. The inching backward becomes active when the CNA #15 (Table 4-5) is closed to a keyswitch controlled voltage.</p>
SET INPUT #2	PRESENT	<p><b>It can be can be set as:</b></p> <ul style="list-style-type: none"> <li>PRESENT: CNA #14 (Table 4-5) is managed as a cutback speed input (SR #2).</li> <li>OPTION #1: CNA #14 (Table 4-5) is managed as an inching backward.</li> </ul> <p>The input CNA #14 (Table 4-5) can only be used as Aux Lifting request when the MDIPRC is PRESENT. This input must be connected to a keyswitch controlled voltage. The SR #2 becomes active when CNA #14 (Table 4-5) is open. The inching backward becomes active when the CNA #14 (Table 4-5) is closed to a keyswitch controlled voltage.</p>
SET INPUT #4	OPTION #1	<p><b>This option handles the digital input CNB #7 (Table 4-5). It can be can be set as:</b></p> <ul style="list-style-type: none"> <li>BELLY CNB #7 (Table 4-5) is managed as a Belly Switch input</li> <li>BRAKE CNB #7 (Table 4-5) is managed as service brake input. This information can be used also to recognize when the operator is driving with a pressed pedal braking.</li> <li>EX.HYDRO: CNB #7 (Table 4-5) is managed as Exclusive Hydro</li> </ul> <p>This input must be connected to a keyswitch controlled voltage. The Belly switch active level is specified on the QUICK INV LOGIC below. The service brake of the exclusive hydro becomes active when CNB #7 is opened.</p>
HOUR COUNTER	RUNNING	<p><b>This option specifies the hour counter mode. It can be set as:</b></p> <ul style="list-style-type: none"> <li>RUNNING: The counter registers travel time only.</li> <li>key on: The counter registers when the keyswitch is closed.</li> </ul>



TABLE 4-2 SET OPTIONS (continued)

PARAMETER	FACTORY SETTING	DESCRIPTION
BATTERY CHECK	Level = 1	<p><b>This option specifies the handling of the low battery charge detection. It can be set as:</b></p> <ul style="list-style-type: none"> <li>Level 0: Nothing happens, the battery charge level is ignored.</li> <li>Level 1: A BATTERY LOW alarm is raised when the battery level is calculated being less than 10% of the full charge. A BATTERY LOW alarm inhibits the Lifting function.</li> <li>Level 2: A BATTERY LOW alarm is raised when the battery level is calculated being less than 10% of the full charge. A BATTERY LOW alarm reduces the maximum truck speed down to 24% of the full truck speed then, if the MDI-PRC is absent, inhibits the Lifting function.</li> <li>Level 3 Equivalent to Level 1; a BATTERY LOW alarm is raised when the battery level is calculated being less than 10% of the full charge. A BATTERY LOW alarm inhibits the Lifting function.</li> </ul>
HYDRO KEY ON	OFF	ON / OFF: If this options is programmed ON the traction Inverter manages a hydraulic steering function when the keyswitch is switched ON (only if the AUX OUTPUT #1 option is programmed as HYDRO CONTACT or as WXCLUSIVE HYDRO).
STOP ON RAMP	OFF	Not used.
AUX OUTPUT #1	BRAKE	<p><b>This option handles output CNA #3 (Table 4-5). It can be used as:</b></p> <ul style="list-style-type: none"> <li>BRAKE: CNA #3 (Table 4-5) drives an electromechanical Brake.</li> <li>HYDROCOMNT: CNA #3 (Table 4-5) drives the contractor for a hydraulic steering function when the direction input or brake pedal input are active or a movement of the truck is detected.</li> <li>EX.HYDRO: CNA #3 (Table 4-5) drives the contractor for a hydraulic steering function when the exclusive hydro input is active.</li> <li>FREE: CNA #3 (Table 4-5) is not used. The current this output can sink is up to 3Adc.</li> </ul>
PEDAL BRAKING	NONE	<p><b>The analog input CNA #18 (Table 4-5) has one of two functions:</b></p> <ul style="list-style-type: none"> <li>Pedal Braking input.</li> <li>Command input for lifting / lowering proportional valves in MDIPRC version. To turn from the first to the second function is just enough to set PEDAL BRAKING to HNONE.</li> </ul> <p><b>This option handles the analog input CNA #18 (Table 4-5) when used as pedal braking input:</b></p> <ul style="list-style-type: none"> <li>ANALOG: With this setting it is possible to modulate the strength of the braking when the accelerator is released. The strength of the braking is proportional to the brake pedal potentiometer connected to this input. When the pedal potentiometer voltage is equal / less than the SET POT BRK MIN, the minimum release braking strength is applied (following the RELEASE BRAKING setting). When the pedal potentiometer voltage is equal / higher than the SET POT BRK MAX, the maximum release braking strength is applied (following the PEDAL BRAKING setting). In the intermediate position, the electrical braking strength is a linear function between the minimum (RELEASED BRAKING) and maximum (PEDAL BRAKING) intensity. When there is also a switch connected to the pedal braking (i.e. SET INPUT #4 to level BRAKE), it must be closed, otherwise the release braking is stuck to the minimum strength disregarding the pedal potentiometer position.</li> <li>DIGITAL: No pedal potentiometer is expected. Only when both the SET INPUT #4 is Level BRAKE and the brake switch connected to CNB #4 (Table 4-5) is closed, the release electrical braking follows the PEDAL BRAKING setting (maximum strength); in all of the other conditions the release electrical braking follows the RELEASE BRAKING setting (minimum strength).</li> <li>NONE: The analog input CNA #18 (Table 4-5) is not used for the release braking modulation.</li> </ul>

TABLE 4-2 SET OPTIONS (continued)

PARAMETER	FACTORY SETTING	DESCRIPTION
QUICK INVERSION	BELLY	<p><b>This option specifies the quick inversion mode when the SET INPUT #4 is set BELLY. It can be set as:</b></p> <ul style="list-style-type: none"> <li>• NONE: The quick inversion function is not managed (no effect when CNB #7 (Table 4-5) switches over).</li> <li>• TIMED: The quick inversion function is timed.</li> <li>• BELLY: The quick inversion function is managed but not timed.</li> </ul>
AUX VOLTAGE #1	100%	<p>This option specifies the percentage of the keyswitch controlled voltage to be applied to the loads on CNA #1 (Table 4-5) (main contactor coil) and CNA #3 (Table 4-5) (electromechanical brake). The voltage modulation is set with a PWM at 1 kHz frequency. After an initial delay of about 1 sec in which the entire keyswitch controlled voltage is applied to the loads, the PWM reduces the voltage at the loads down to the specified percentage.</p>
PERFORMANCE	OPTION #1	<p><b>This option can be set:</b></p> <ul style="list-style-type: none"> <li>• OPTION #1</li> <li>• OPTION #2</li> </ul>
QUICK INV. LOGIC	OPTION #1	<p><b>This option specifies the active level for the Belly switch input (CNB #7):</b></p> <ul style="list-style-type: none"> <li>• OPTION #1: The quick inversion is executed when CNB #7 (Table 4-5) is closed to a keyswitch controlled voltage.</li> <li>• OPTION #2: The quick inversion is executed when CNB #7 (Table 4-5) is opened from a keyswitch controlled voltage.</li> </ul>
MDI-PRC	ABSENT	<p><b>This option specifies:</b></p> <ul style="list-style-type: none"> <li>• PRESENT: The MDI-PRC is connected to the ACO via the CAN</li> <li>• BUS: the handling of the Hydraulics is specified on the TRUCK TYPE setting.</li> <li>• ABSENT: The MDI-PRC is not connected to the ACO: the TRUCK</li> <li>• TYPE: disappears from the SET OPTIONS function list.</li> </ul>
MOT SET-UP	OFF	Not used

6.2.4.2 ADJUSTMENTS

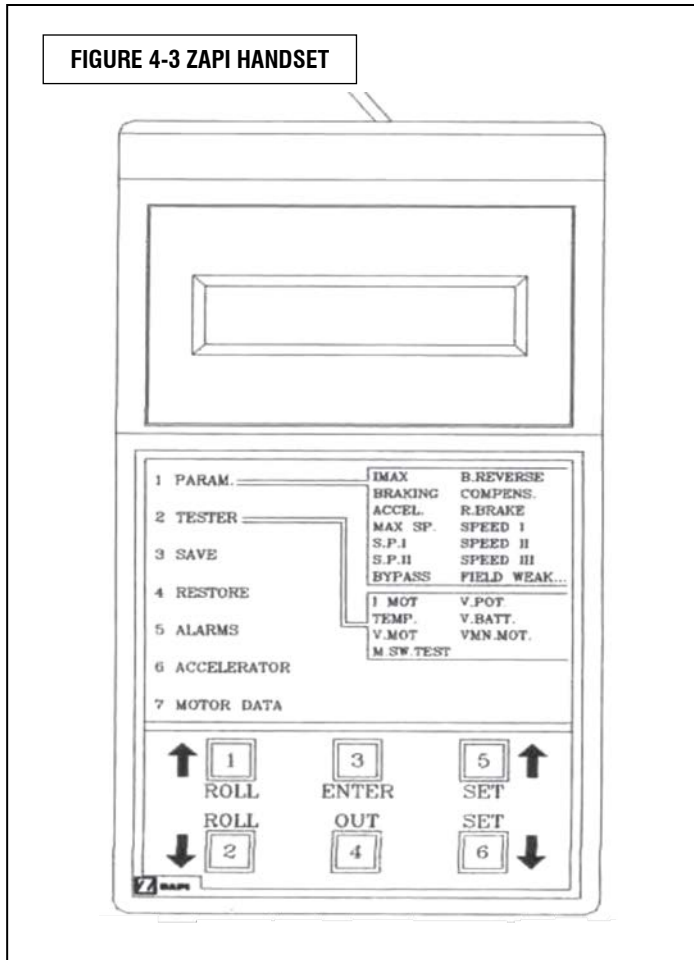

To change an adjustment proceed as follows and refer to **Table 4-3**:

1. Connect the Zapi Handset, refer to paragraph 6-2.1.
2. Press the ROLL up button (1, **Figure 4-3**) and the SET up button (5) at the same time to enter the CONFIG MENU.
3. Press the ROLL down button (1) or the ROLL up button (2) to find the ADJUSTMENTS display.
4. Press the ENTER button (3) to view the adjustments.
5. Press the ROLL down button (2) or the ROLL up button (1) to find the adjustment to be changed.
6. Press the SET up button (5) or the SET down button (6) until the desired value setting is reached. The adjustment is now set at the desired value.
7. Press the OUT button (4) to exit the adjustments.

**TABLE 4-3 ADJUSTMENTS**

PARAMETER	FACTORY SETTING	DESCRIPTION
SET POT BRK MIN	0.5 V	This setting records the minimum value of braking pedal potentiometer when the braking pedal switch is closed; the procedure is similar to the PROGRAM VACC function. This procedure must be carried out only if the PEDAL BRAKING option is programmed as ANALOG. No adjustment is necessary when PEDAL BRAKING options is programmed as NONE.
SET POT BRK MAX	4.5 V	This setting records the maximum value of braking pedal potentiometer when the braking pedal is fully pressed; the procedure is similar to the PROGRAM VACC function. This procedure must be carried out only if the PEDAL BRAKING option is programmed as ANALOG. No adjustment is necessary when PEDAL BRAKING options is programmed as NONE.
SET BATTERY TYPE	24V	Selects the nominal battery voltage.
ADJUST BATTERY	XX V	Do not modify - Factory adjusted (Fine adjustment of the battery voltage measured by the controller).
THROTTLE 0 ZONE	9%	Establishes a deadband in the accelerator input curve.

**TABLE 4-3 ADJUSTMENTS (continued)**

PARAMETER	FACTORY SETTING	DESCRIPTION
THROTTLE X POINT	45%	This parameter together with the THROTTLE Y POINT, changes the characteristic of the accelerator input curve: when the accelerator is de-pressed to X point percent, the corresponding truck speed is Y point percent of the Maximum truck speed. The relationship between the accelerator position and the truck speed is linear between the THROTTLE 0 ZONE and the X point and also between the X point and the maximum accelerator position but with two different slopes ( <b>Figure 4-4</b> ).
THROTTLE Y POINT	68%	This parameter together with the THROTTLE X POINT, changes the characteristic of the accelerator input curve: when the accelerator is de-pressed to X point percent, the corresponding truck speed is Y point percent of the Maximum truck speed. The relationship between the accelerator position and the truck speed is linear between the THROTTLE 0 ZONE and the X point and also between the X point and the maximum accelerator position but with two different slopes ( <b>Figure 4-4</b> ).
ADJUSTMENT #01	LEVEL = 5	Adjust the upper level of the battery charge table (Level 0 to 9).
ADJUSTMENT #02	LEVEL = 5	Adjust the lower level of the battery charge table (Level 0 to 9).
LOAD HM FROM MDI	OFF	When set On, the Hourmeter of the Controller is transferred and recorded on the Hourmeter of the Standard MDI (connected on the Serial Link).
CHECK UP DONE	OFF	Turn it On when asked Maintenance service has been executed to cancel the CHECK UP NEEDED warning.
CHECK UP TYPE	NONE	<p><b>It specifies the handling of the CHECK UP NEEDED warning:</b></p> <ul style="list-style-type: none"> <li>• NONE: No CHECK UP NEEDED warning.</li> <li>• OPTION #1: CHECK UP NEEDED warning on the handset and MDIPRC after 300 hours.</li> <li>• OPTION #2: Equal to OPTION #1 but Speed reduction after 340 hours.</li> <li>• OPTION #3: Equal to OPTION #2 but the truck definitively stops after 380 hours.</li> </ul>

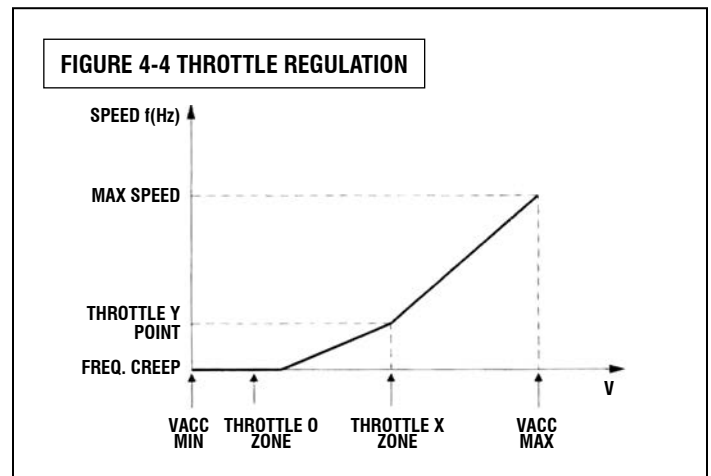

**6.2.4.3 PARAMETER CHANGE**

To change a parameter proceed as follows and refer to **Table 4-4**:

1. Connect the Zapi Handset, refer to paragraph 6-2.1.
2. Press the ROLL down button (1, **Figure 4-5**) and the ENTER button (3) at the same time to enter the MAIN MENU.
3. Press the ROLL down button (1) or the ROLL up button (2) to find the PARAMETER CHANGE display.
4. Press the ENTER button (3) to view the parameters.
5. Press the ROLL down button (2) or the ROLL up button (1) to find the parameter to be changed.
6. Press the SET up button (5) or the SET down button (6) until the desired value setting is reached. The parameter is now set at the desired value.
7. Press the OUT button (4) to exit the parameters.

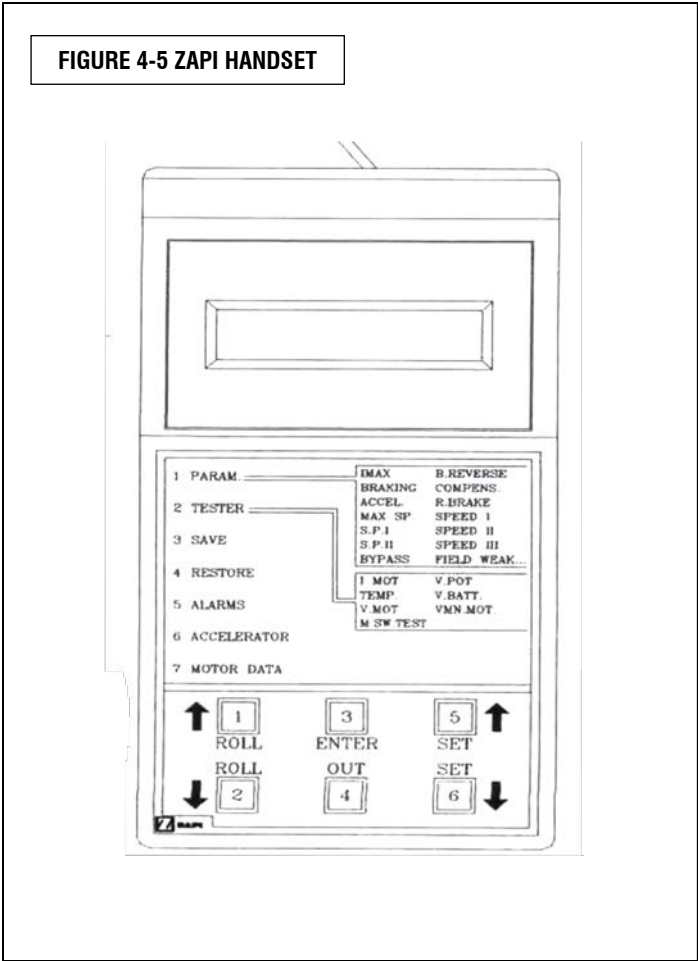

**TABLE 4-4 PARAMETER ADJUSTMENTS**

PARAMETER	FACTORY SETTING	DESCRIPTION
<b>ACCELER. DELAY</b>	LEVEL = 8	Level 0 to 9. It determines the acceleration ramp. At Level 9 the truck takes a long time to accelerate.
<b>RELEASE BRAKING</b>	LEVEL = 5	Level 0 to 9. It controls the deceleration ramp when the travel request is released. At Level 9 the truck brakes abruptly.
<b>INVERS. BRAKING</b>	LEVEL = 4	Level 0 to 9. It controls the deceleration ramp when the direction switch is inverted during travel. At Level 9 the truck brakes abruptly.
<b>PEDAL BRAKING</b>	LEVEL = 9	Level 0 to 9. It controls the deceleration ramp when the travel request is released and the brake pedal switch is pressed to its maximum. At Level 9 the truck brakes abruptly.

**TABLE 4-4 PARAMETER ADJUSTMENTS (continued)**

PARAMETER	FACTORY SETTING	DESCRIPTION
<b>SPEED LIMIT BRK</b>	LEVEL = 1	Level 0 to 9. It controls the deceleration ramp when the accelerator has turned down but not completely released. At Level 9 the truck decelerates abruptly.
<b>BRAKE CUTBACK</b>	LEVEL = 5	Level 0 to 9. It controls the deceleration ramp when the a speed reduction input becomes active and the motor slows down. At Level 9 the truck decelerates abruptly.
<b>MAX SPEED FORW</b>	100 Hz	Typically from 90 Hz to 160 Hz. It determines the maximum speed in forward direction.
<b>CUTBACK SPEED</b>	100%	Typically from 10% to 100%. It determines the percentage of the max speed applied when the cutback switch 1 (SR #1 on CNA #15 (Table 4-5) is active. When set to 100% the speed reduction is ineffective.
<b>CUTBACK SPEED 2</b>	37%	Typically from 10% to 100%. It determines the percentage of the max speed applied when the cutback switch 2 (SR #2 on CNA #14 (Table 4-5) is active. When set to 100% the speed reduction is ineffective.
<b>HS CUTBACK</b>	100%	Typically from 10% to 100%. It determine the percentage of the max speed applied when the Hard and Soft function (H&S switch on CNB #4 (Table 4-5) is active. When set to 100% the speed reduction is ineffective.
<b>FREQUENCY CREEP</b>	5.00 Hz	Hz value. This is the minimum speed applied when the forward or reverse switch is closed, but the accelerator at its minimum. In the ACO sense Coils this setting is higher equal than 5 Hz.
<b>RPM CREEP</b>	100%	A Percentage value. Set to 100% and not used.
<b>MAXIMUM CURRENT</b>	96%	It specifies the percentage of the absolute current (150A) at which the current will be limited. Normally MAXIMUM CURRENT is 100%. DO NOT CHANGE.
<b>INCHING SPEED</b>	0 Hz	Hz value. It determines the speed when the “Inching function” is active.
<b>INCHING TIME</b>	LEVEL = 0	Level 0 to 9. It determines the duration time when the “Inching function” is active.
<b>AUXILIARY TIME</b>	1	Time units value (seconds). For the encoder version, it determines the time duration (in seconds) in which the the frequency was arrived to zero.
<b>AUXILIARY TIME</b>	1	A Percentage of the Maximum Current. This setting increases the phase current when low frequency during starting operation. It is used to push up, in feedforward way, the torque when it is not possible to control the flux, in feedback way, because of the low frequency.

**FIGURE 4-6 ZAPI CONTROLLER CONNECTORS**

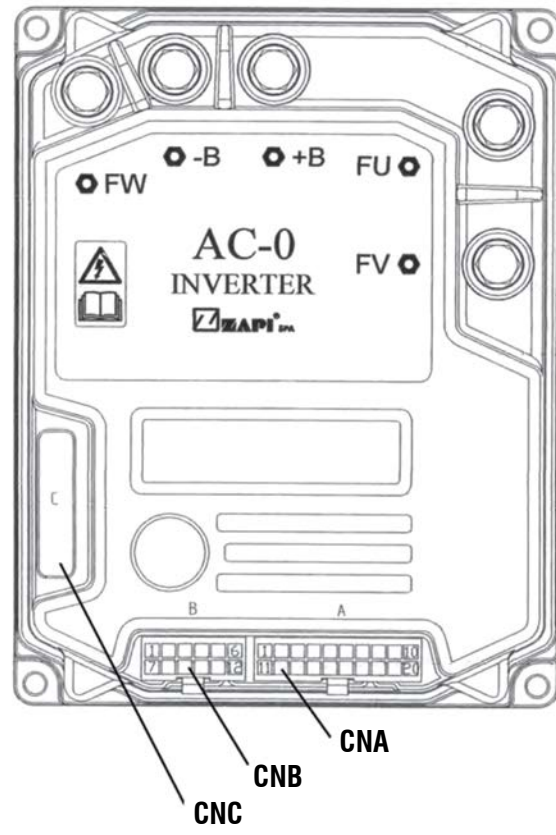

**TABLE 4-5 ZAPI CONTROLLER CONNECTOR PINS, CNA CONNECTOR**

PIN	ABBREVIATION	DESCRIPTION
CNA #1	NMC	Negative of main contactor coil.
CNA #2	PMC	Positive of main contactor coil.
CNA #3	NEB	Output for driving the electromechanical brake coil; drives the load to -Batt. Maximum current: 3 A.
CNA #4	NPC	Negative of pump contactor soil.
CNA #5	PPC / PEV	Positive of pump contactor coil and lowering electrovalve coil.
CNA #6	NEV	Negative of the lowering electrovalve coil.
CNA #7	CAN LOW	Low level CAN-BUS voltage I/O.
CNA #8	-BAT	-Bat.

**TABLE 4-5 ZAPI CONTROLLER CONNECTOR PINS, CNA CONNECTOR (continued)**

PIN	ABBREVIATION	DESCRIPTION
CNA #9	ENC+	Encoder Positive Supply (+5 or +12 VDC)
CNA #10	ENC-	Encoder Negative Supply (GND to minus battery)
CNA #11	HM(+B)	Output for driving an hourmeter; when the hourmeter is active this output provides a + Batt signal; 3 maximum current.
CNA #12	-BATT	-Batt
CNA #13	MOT TH	Motor thermal sensor input. The internal pull-up is a fixed 2mA (Max 5V) source current.
CNA #14	SR2	Speed reduction 2 input. Active low (switch opened).
CNA #15	SR1	Speed reduction 1 input. Active low (switch opened).
CNA #16	+12V	This output provides a +12V signal for the MDI PRC, it present; mA maximum current.
CNA #17	CAN HIGH	High level CAN-BUS voltage I/O
CNA #16	CPOTB	Brake potentiometer wiper
CNA #19	ENC A	Encoder Channel A
CNA #20	ENC B	Encoder Channel B

**TABLE 4-5 ZAPI CONTROLLER CONNECTOR PINS, CNB CONNECTOR**

CONNECTOR PIN	ABBREVIATION	DESCRIPTION
CNB #1	KEY SW	Connected to the power supply through a microswitch (KEY) with a 6.3-10 A fuse in series (this could be mounted on the AC-0 cover).
CNB #2	CM	Common for FW / BW / SR1 / SR2 / TILLER / H&S / BELLY / LIFTING / LOWERING microswitches. This connection supplies a keyswitch voltage level.
CNB #3	TILLER SW	Tiller request input. Must be connected to the tiller microswitch, active high.
CNB #4	H&S SW	Hard and Soft request input. Must be connected to the Hard and Soft microswitch, active high.
CNB #5	BACKWARD SW	Backward direction request input. Must be connected to the backward direction microswitch, active high.
CNB #6	FORWARD SW	Forward direction request input. Must be connected to the forward direction microswitch, active high.
CNB #7	BELLY SW	Quick inversion function input; must be connected to the Belly microswitch; it is active high.



**TABLE 4-5 ZAPI CONTROLLER CONNECTOR PINS, CNB CONNECTOR (continued)**

CONNECTOR PIN	ABBREVIATION	DESCRIPTION
CNB #8	LOWERING SW	Lowering request input, active high.
CNB #9	LIFTING SW	Lifting request input, active high voltage level.
CNB #10	CPOT	Lifting request input, active high.
CNB #11	NPOT	Negative of accelerator unit, tested for wire disconnection diagnosis.
CNB #12	PPOT	Potentiometer positive: 10V output; keep load > 1k

**TABLE 4-5 ZAPI CONTROLLER CONNECTOR PINS, CNC CONNECTOR**

CONNECTOR PIN	ABBREVIATION	DESCRIPTION
CNC #1	PCLRxD	Positive serial reception
CNC #2	NCLRxD	Negative serial reception
CNC #3	PCLTxD	Positive serial transmission.
CNC #4	NCLTxD	Negative serial transmission
CNC #5	GND	Negative console power supply
CNC #6	+12V	Positive console power supply
CNC #7	FLASH	Must be connected to C8 for the Flash memory programming (if used)
CNC #8	FLASH	Must be connected to C7 for the Flash memory programming (if used)

## 7.0 STEERING ARM, CONTROL HEAD AND COMPARTMENT

FIGURE 5-1 CONTROL HEAD

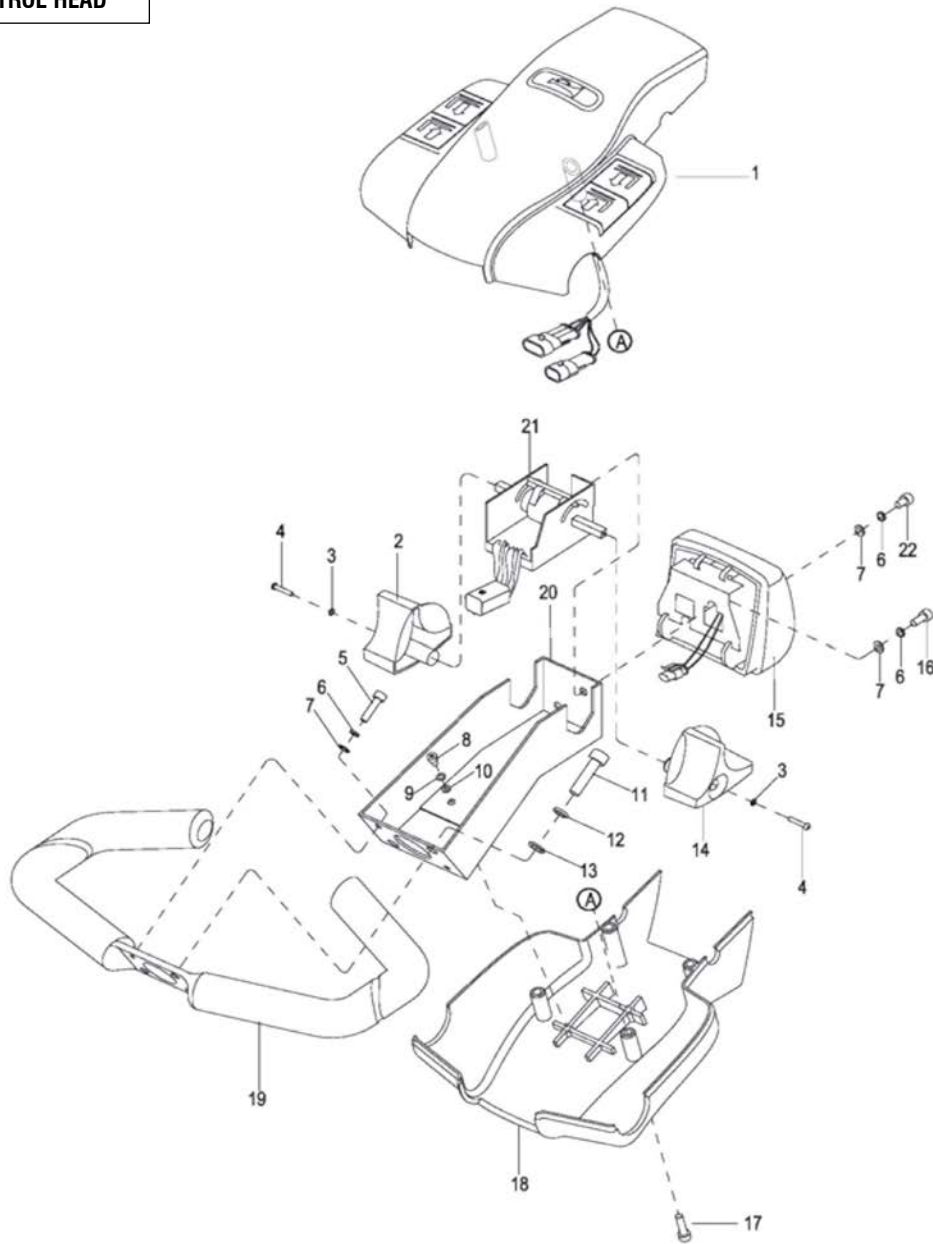

### 7.1 CONTROL HEAD

#### 7.1.1 CAP ASSEMBLY REMOVAL

1. Turn off the key switch and disconnect the batteries.
2. Remove four screws, lift up cap assembly and disconnect harness from harness.

7.1.2 CAP ASSEMBLY INSTALLATION

1. Hold cap assembly in place and connect harness (23) to harness.
2. Position cap assembly on control head and secure with four screws.
3. Reconnect the batteries and turn on the key switch.

WARNING

When removing the control head in the following steps, be sure to hold it in place until the control harness is disconnected.

**FIGURE 5-2 STEERING ARM**

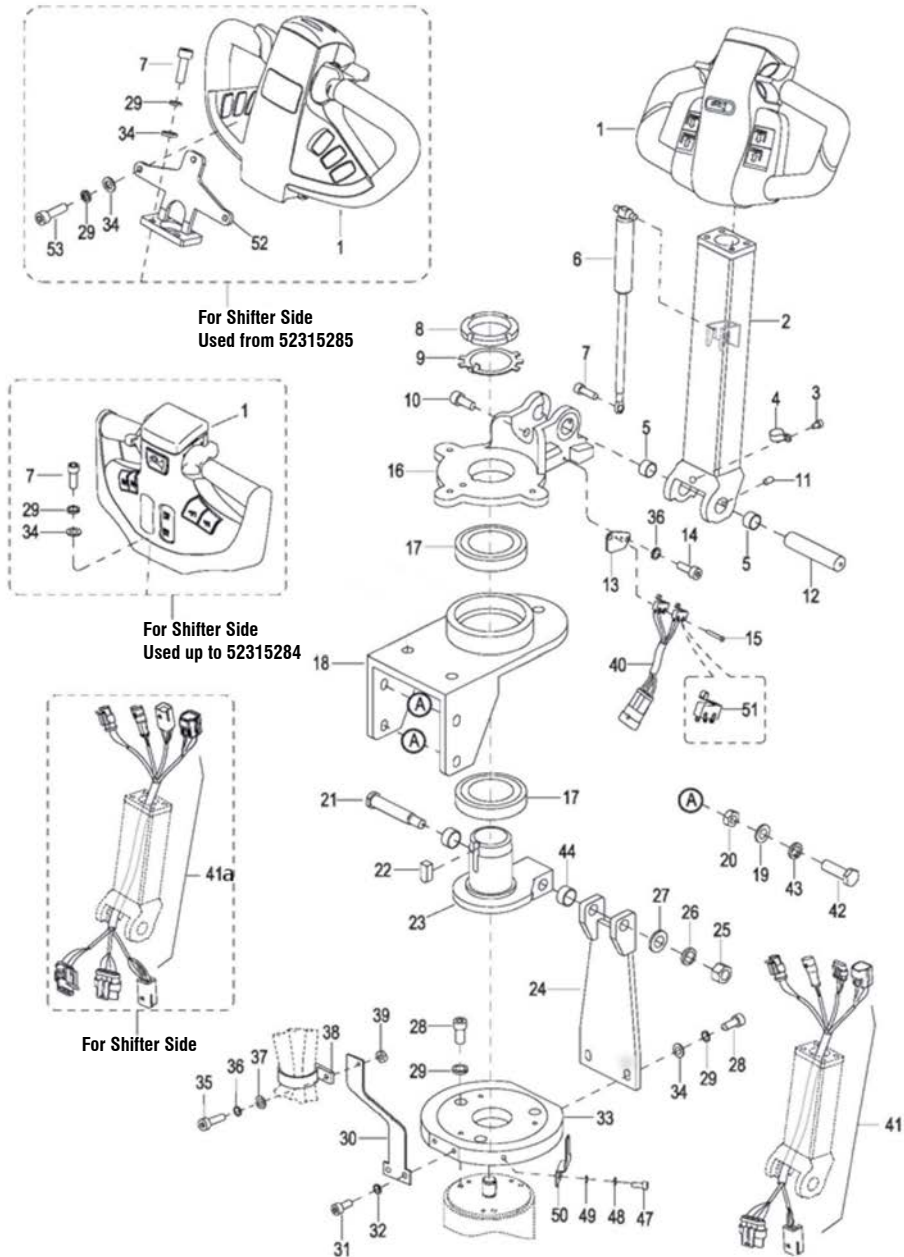

### 7.1.3 CONTROL HEAD REMOVAL

1. Remove the cap assembly as described in paragraph 7-1.1.
2. Disconnect harness from potentiometer and reversing switch.
3. Remove two screws, two lock washers and two flat washers.



## WARNING

When removing the control head in the following steps, be sure to hold it in place until the control harness is disconnected.

4. Remove two screws, two washers and two flat washers.
5. Remove the control head and handle.

### 7.1.4 CONTROL HEAD INSTALLATION

1. Hold control head and handle in place and install two screws, two washers and two flat washers.
2. Install two screws, two lock washers and two flat washers.
3. Reconnect harness to potentiometer and reversing switch.
4. Install the cap assembly as described in paragraph 7-1.2.

### 7.1.5 SPEED POTENTIOMETER REPLACEMENT

1. Remove the cap assembly as described in paragraph 7-1.1.
2. Disconnect harness from potentiometer.
3. Remove screw, washer and control knob from potentiometer.
4. Remove screw, washer and control knob from other side of potentiometer.
5. Remove screw, lock washer and flat washer.
6. Remove screw, lock washer and flat washer and remove potentiometer from bracket.
7. Position new potentiometer in bracket and secure with screw, lock washer and flat washer.
8. Install screw, lock washer and flat washer.
9. Install control knob on potentiometer and secure with screw, and washer.
10. Install control knob on the other side of potentiometer and secure with screw, and washer.
11. Connect harness to potentiometer.
12. Install the cap assembly as described in paragraph 7-1.2.

### 7.1.6 BELLY-BUTTON SWITCH REPLACEMENT

1. Remove the cap assembly as described in paragraph 7-1.1.
2. Disconnect harness from reversing switch.
3. Remove screw, lock washer and flat washer.
4. Remove screw, lock washer and flat washer and remove switch assembly from bracket.

5. Remove pin and bracket, and spring from button.
6. Remove two pins and switch assembly from bracket.
7. Position the new switch assembly in bracket and secure with two pins.
8. Position bracket in button and install pin.
9. Position switch assembly on bracket and secure with two screws.
10. Reconnect harness to reversing switch.
11. Install the cap assembly as described in paragraph 7-1.2.

### 7.1.7 HORN SWITCH REPLACEMENT

1. Remove the cap assembly as described in paragraph 7-1.1.
2. Remove three screws, bracket and springs.
3. Remove two pins and defective switch from bracket.
4. Unsolder harness from defective switch and connect it to the new switch.
5. Position the new switch in bracket and secure with two pins.
6. Position bracket in cover and secure with three screws.
7. Install the cap assembly as described in paragraph 7-1.2.

### 7.1.8 LIFT AND LOWER SWITCH REPLACEMENT

1. Remove the cap assembly as described in paragraph 7-1.1.
2. Remove switch assembly from cap.
3. Remove pin securing buttons and remove the buttons.
4. Remove two pins, two switches and four springs from bracket.
5. Unsolder harness from defective switch.
6. Solder the harness to new switch.
7. Position the new switches and four springs in bracket and secure with two pins.
8. Position switch assembly in cover and secure with pin.
9. Install the cap assembly as described in paragraph 7-1.2.

FIGURE 5-3 EMERGENCY REVERSE SWITCH ASSEMBLY

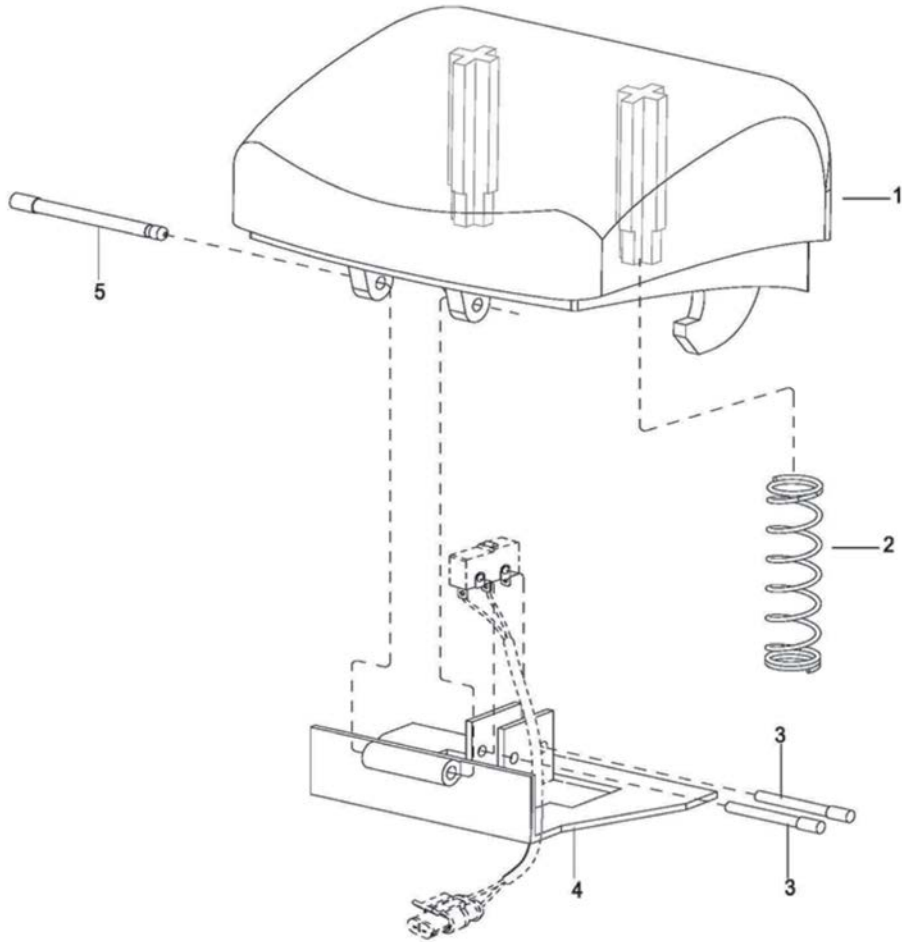
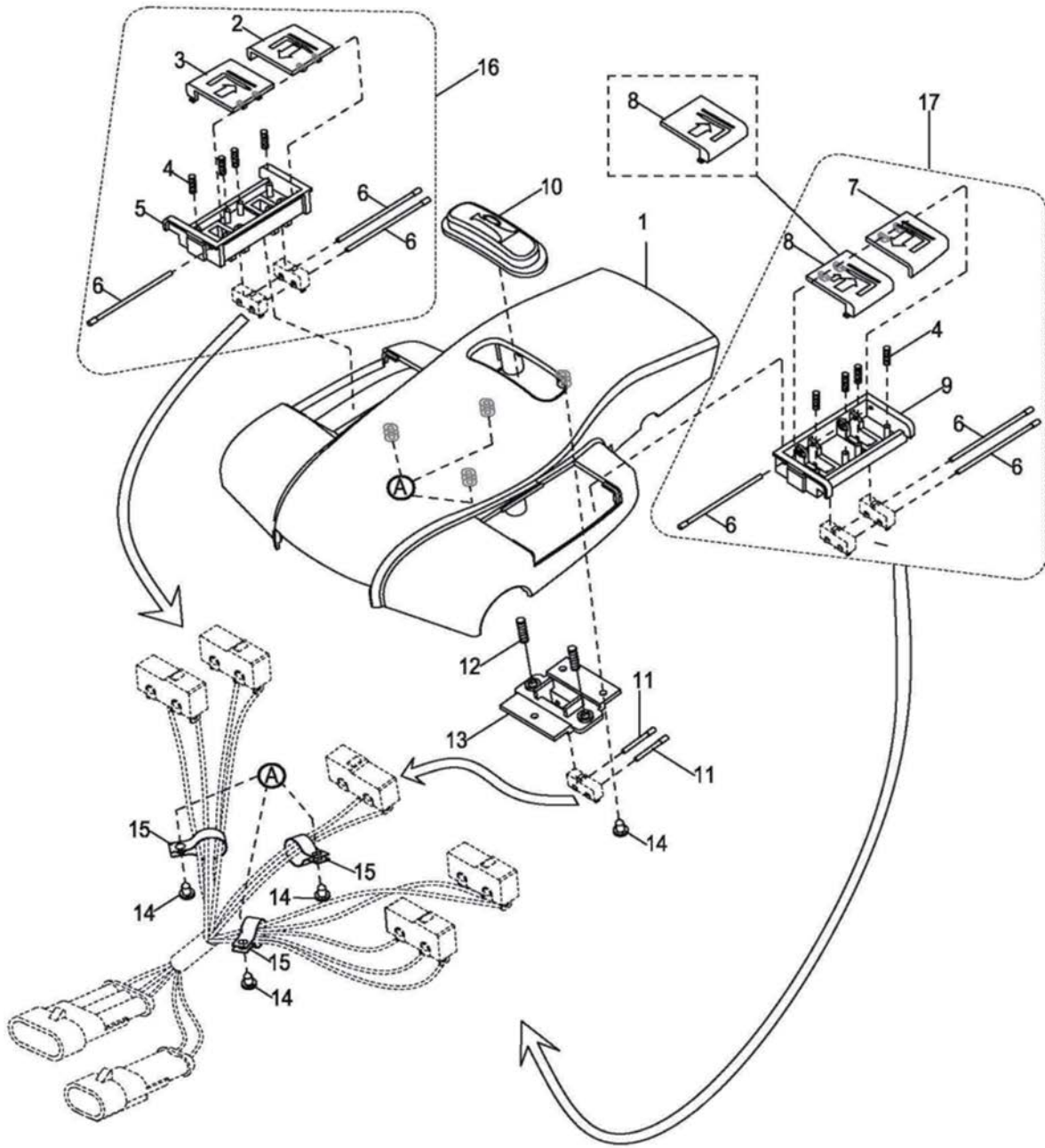

FIGURE 5-4 CAP ASSEMBLY



## 7.2 STEERING ARM

### 7.2.1 RETURN SPRING REPLACEMENT

1. Turn off the key switch and disconnect the batteries.
2. Remove three screws and middle cover.
3. Secure the steering arm in the upright position.
4. Remove screw and free the gas return spring from bracket.
5. Pull downward on the gas return spring to free it from its seat inside steering arm.
6. Position the new gas return spring inside the steering arm being sure it fully engages its seat.
7. Position the opposite end of the gas return spring on bracket and install screw.
8. Install middle cover and secure with three screws.
9. Reconnect the batteries and turn on the key switch.

### 7.2.2 STEERING ARM REMOVAL

1. Turn off the key switch and disconnect the batteries.
2. Disconnect harness from harness.
3. Attach a hoist to steering arm.
4. Remove screw, shaft and the steering arm.

### 7.2.3 STEERING ARM INSTALLATION

1. Position steering arm over the bracket and secure with the shaft and screw.
2. Reconnect harness from harness.
3. Reconnect the batteries and turn on the key switch.

## 7.3 COMPARTMENT COVERS

### 7.3.1 REMOVAL

1. Turn off the key switch and disconnect the batteries.
2. Remove three screws and middle cover.
3. Remove three screws and upper cover.
4. Remove two screws and two washers.
5. Open covers.

### 7.3.2 INSTALLATION

1. Close covers.
2. Install two screws and two washers.
3. Install upper cover and secure with three screws.
4. Install middle cover and secure with three screws.
5. Reconnect the batteries and turn on the key switch

## 8.0 BRAKE SERVICING

### 8.1 BRAKES

The brake system consists of a drive motor mounted brake. This brake is spring applied and electrically released.

#### 8.1.1 AIR GAP ADJUSTMENT

The "air gap" is the distance between the magnet body and the rotor plate with the brake applied. As the brake pads and rotor wear normally, the air gap will increase and should be readjusted when it measures more than 0.25 mm.

**NOTE:** If the air gap measures more than 0.25 mm, the brake may not release properly. Air gap adjustment can be performed as long as the brake pads and rotor function properly or until the adjustable spacer threads are fully engaged (adjustment limit reached).

1. Block load wheels.
2. Remove the compartment covers as described in paragraph 7-3.
3. Using low pressure air, remove any dirt between armatures and magnet body.
4. Using standard feeler gauges, check the gap between the magnet body and the rotor plate. The gap should be 0.25 mm.
5. If necessary, refer to **Figure 6-1** and adjust the gap as follows:
  - a. Loosen the three mounting screws by half a turn.
  - b. The threaded air gap adjusting nuts can then be screwed into Magnet Body by turning counterclockwise.
  - c. Turn the three mounting screws clockwise until the gap measures 0.012" (0.25 mm).
  - d. The threaded air gap adjusting nuts are then screwed clockwise until they bottom.
  - e. Finally tighten the three mounting screws to 52 in-lb (6 Nm).
  - f. Recheck the gap.
6. Remove load wheel blocks and check operation.
7. Install the compartment covers as described in paragraph 7-3.

FIGURE 6-1 BRAKE ASSEMBLY

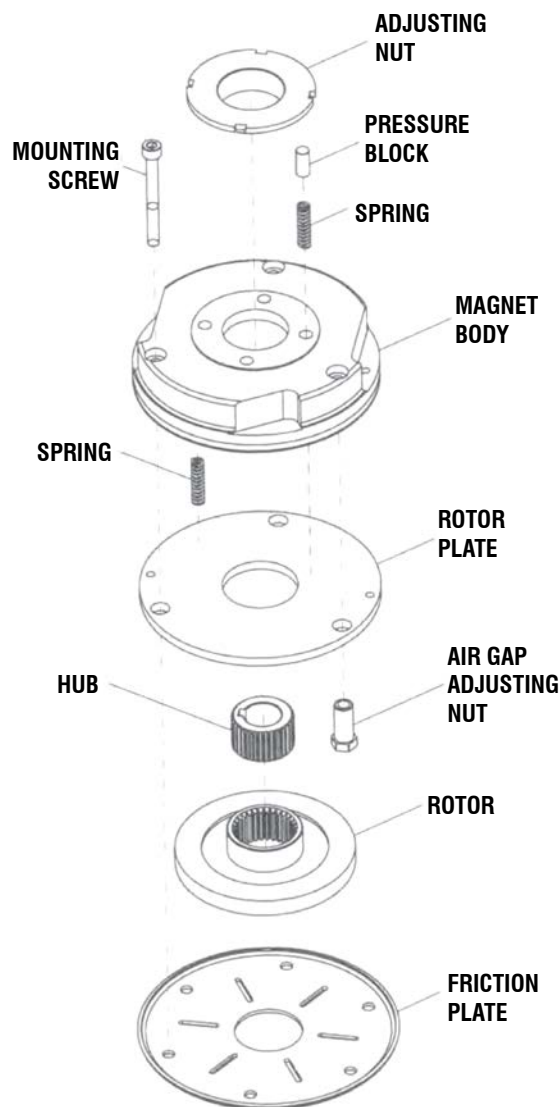

### 8.1.2 STOPPING DISTANCE ADJUSTMENT

The stopping distance of the truck should require minimal adjustment. However, this distance should be checked with each planned maintenance. Using an unloaded truck, run truck to its top speed on an even dry concrete surface. Move control handle into the lower braking position. Measure length of braking path from the actuation point of the brakes until the truck has stopped. The actual length of the braking path should be between approximately 1.5 - 2.5 ft (0.5-0.7 m).

To adjust stopping distance, proceed as follows:

1. Block load wheels.
2. Remove the compartment covers as described in paragraph 7-3.
3. Rotate the adjusting nut (**Figure 6-1**) clockwise to SHORTEN the stopping distance or counterclockwise to LENGTHEN the stopping distance.
4. Remove load wheel blocks and check operation.
5. Install the compartment covers as described in paragraph 5-3.

### 8.1.3 BRAKE ASSEMBLY REPLACEMENT

1. Block load wheels.
2. Remove the compartment covers as described in paragraph 7-3.
3. Disconnect electric brake from harness.
4. Remove the three mounting screws (**Figure 6-1**) and the brake.
5. Place the new brake into position and secure with the three mounting screws.
6. Finally tighten the three mounting screws to 52 inlb (6 Nm).
7. Reconnect electric brake from harness.
8. Remove load wheel blocks and check operation.
9. Install the compartment covers as described in paragraph 7-3.

## 9.0 TRANSMISSION, DRIVE WHEEL, LOAD WHEEL

### 9.1 DRIVE WHEEL

1. Turn off the key switch and disconnect the batteries.
2. Remove the compartment covers as described in paragraph 7-3.
3. Loosen but do not remove the five nuts.
4. Jack up the truck so the drive wheel is off the ground; then securely block the truck to prevent movement.
5. Remove the five nuts five washers and drive wheel from the transmission.
6. Install new drive wheel in reverse order of removal.
7. Install the compartment covers as described in paragraph 7-3.
8. Reconnect the batteries and turn on the keyswitch.

### 9.2 TRANSMISSION

1. Turn off the key switch and disconnect the batteries.
2. Remove the compartment covers as described in paragraph 7-3.
3. Remove the brake as described in paragraph 8- 1.3.
4. Remove the drive wheel as described in paragraph 9-1.
5. Remove two screws, two lock washers and two flat washers.
6. Note routing of cables to ensure proper installation.
7. Tag the cables connected to the drive motor; then disconnect these cables from the drive motor.
8. Support the transmission and remove the six screws, six lock washers and six flat washers.
9. Slowly lower the transmission out the bottom of the frame.
10. Install new transmission by reversing the steps above.



## 9.3 LOAD WHEEL

### 9.3.1 REMOVAL

1. Raise forks.
2. Turn off the key switch and disconnect the batteries.
3. Block the drive wheel to prevent the truck from rolling.
4. Jack up the forks to raise the load wheels off the floor. Securely block the forks in the raised position by positioning supports under both fork tips.
5. Remove screw or retaining ring securing shaft.

**NOTE:** When shaft is removed, load wheel will drop free.

6. Remove shaft, load wheel and washers.
7. Remove bearings from load wheel.

**NOTE:** Inspect the load wheel assembly. If the load wheel is worn within 1/8" of the metal sleeve, or is cracked or damaged, replace the entire load wheel and bearing assembly. Blue Giant recommends that both load wheel assemblies be replaced at the same time. This ensures level and safe operation of the lift truck.

### 9.3.2 LOAD WHEEL INSTALLATION

**NOTE:** Adjustable straddle shown, fixed straddle similar.

1. Install bearings in load wheel.
2. Position load wheel and washers in straddle.
3. Install shaft and secure with screw or retaining ring.
4. Remove blocking from under the truck.
5. Lower the forks.
6. Reconnect the batteries and turn on the keyswitch.

FIGURE 7-1 TRANSMISSION, MOTOR, BRAKE ASSEMBLY

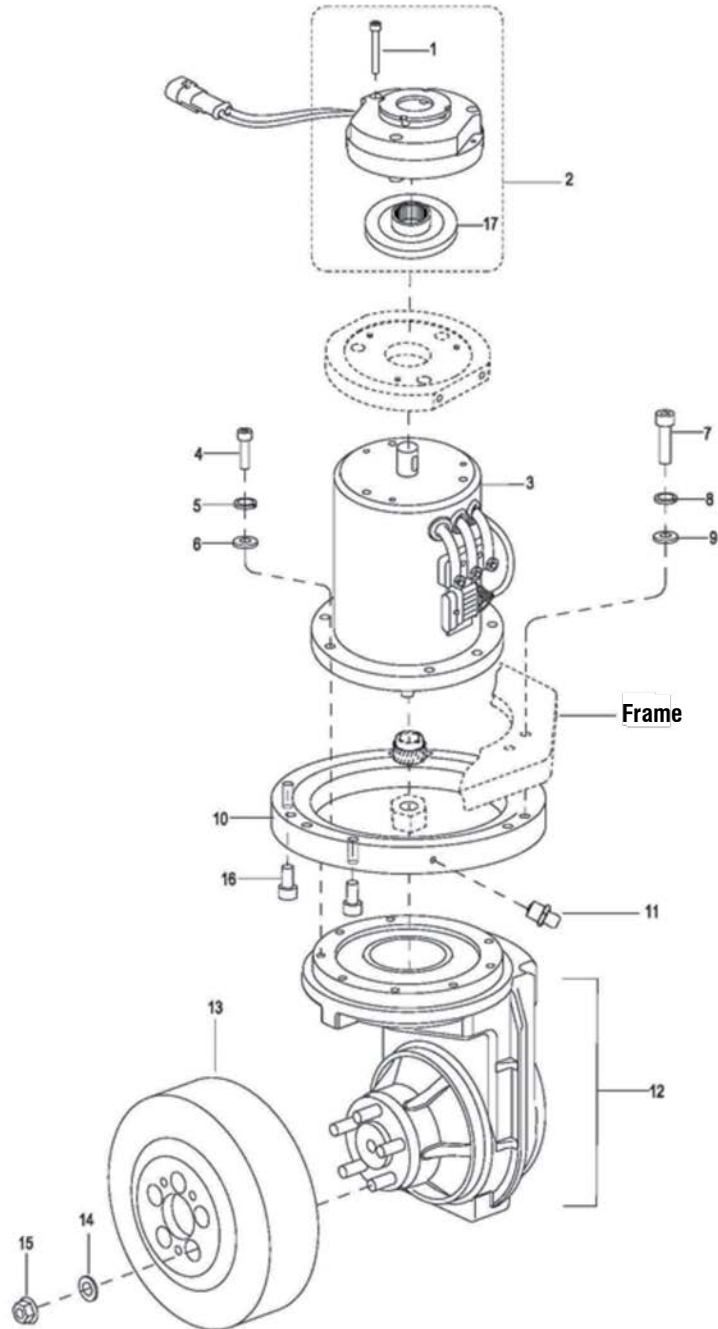

**FIGURE 7-2 ADJUSTABLE STRADDLE**

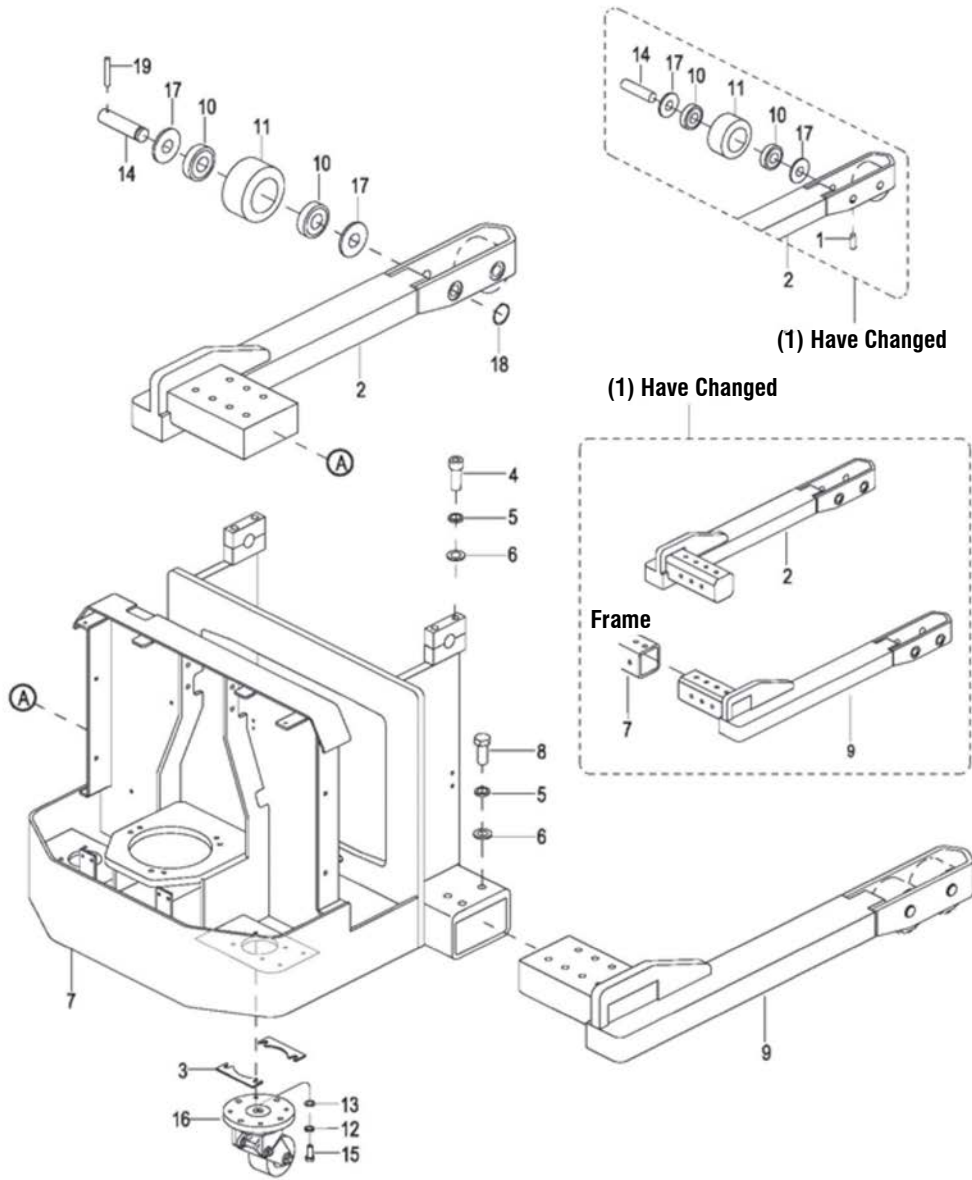

## 10.0 ELEVATION SYSTEM SERVICING

### 10.1 GENERAL

The elevation system includes the outer mast, inner mast, lift linkage, lift chains, lift cylinder and ram head.

### 10.2 LIFT CHAIN LENGTH ADJUSTMENT

#### 10.2.1 TELESCOPIC

1. Fully lower the fork carriage.
2. Turn off the key switch and disconnect the batteries.
3. Loosen jam nuts (2, **Figure 8-1**), located the above the mount of outer mast (20, **Figure 8-2**), to allow for adjustment of middle jam nut.



### WARNING

Before attempting any adjustment, make certain power is disconnected.

4. Break the lower jam nuts (2, **Figure 8-1**), located below the mount of outer mast, free from the middle jam nuts (2).
5. Take up slack in both lift chains with middle jam nut (2). Strive for equal tension on both chains.
6. Align anchors (1) so each clevis pin (4) is parallel to outer mast cross (20, **Figure 8-2**).
7. Tighten jam nuts securely while maintaining alignment of clevis pins (4).



### CAUTION

At least 3 full threads must be present below lower nut (2, **Figure 8-1**) after adjustment.

8. Reconnect the batteries and turn on the keyswitch.
9. Test chain by operating carriage. If slack is still apparent, repeat above procedure.

FIGURE 8-1 CHAIN ASSEMBLY

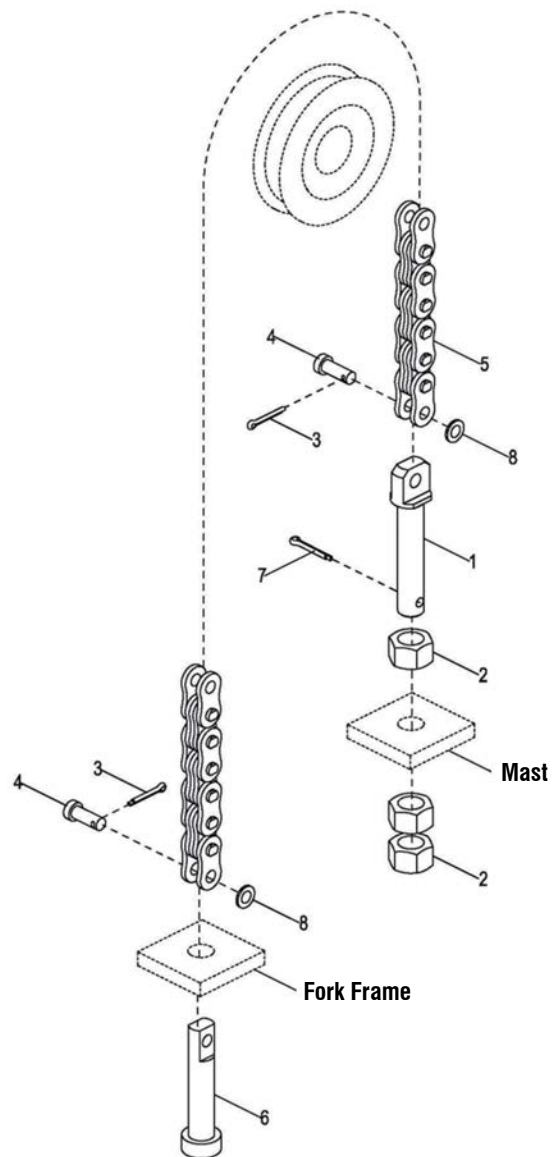
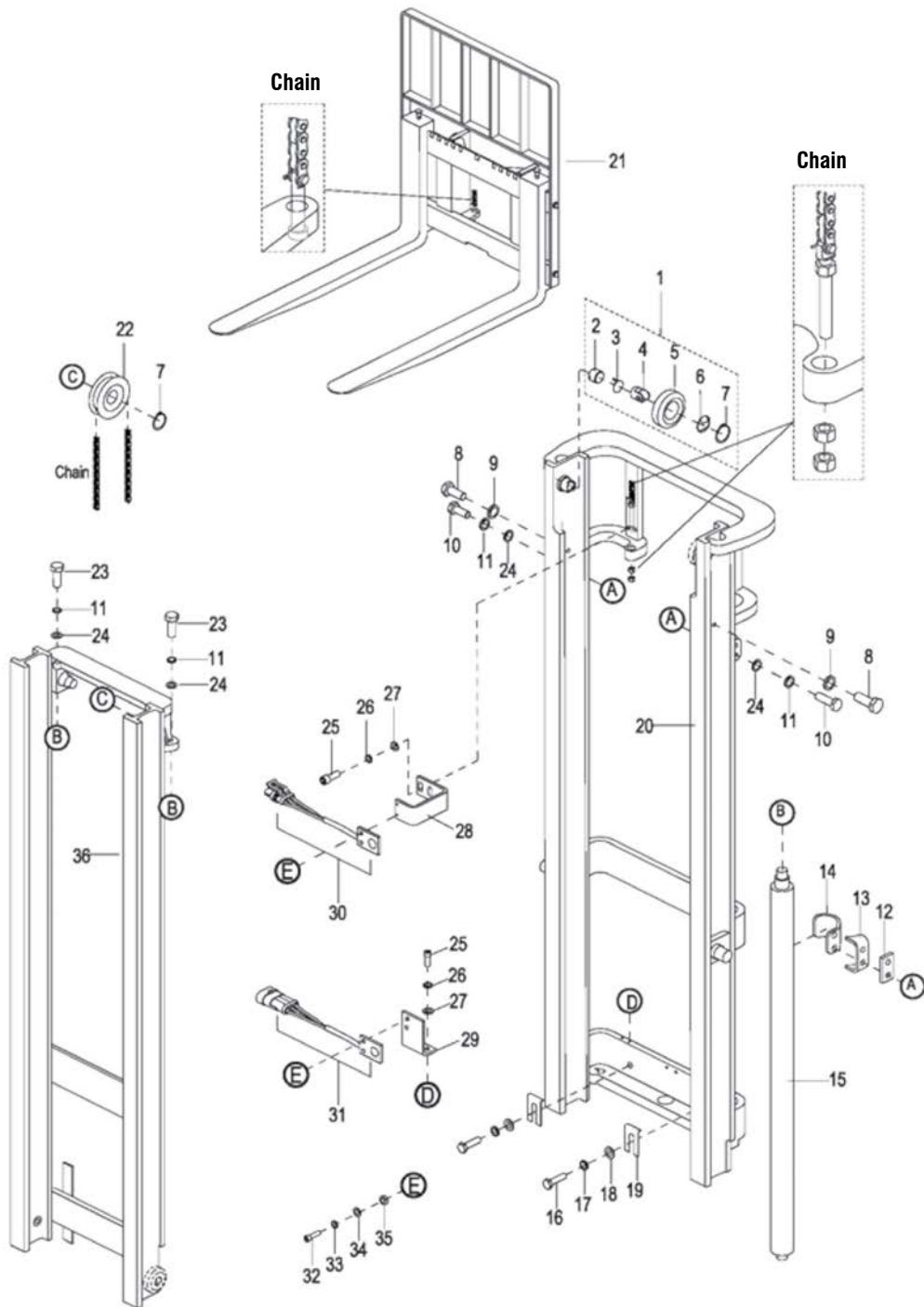

FIGURE 8-2 ELEVATION SYSTEM (TELESCOPIC)



### 10.2.2 TRIMAST FREE LIFT CHAIN

1. Fully lower the lift carriage.
2. Turn off the key switch and disconnect the batteries.



#### WARNING

Before attempting any adjustment, make certain power is disconnected.

3. Loosen jam nuts located the above the mounts of cylinder, to allow for adjustment of middle jam nut.
4. Break the lower jam nuts located below the mounts of cylinder free from the middle jam nuts.
5. Take up slack in both lift chains with middle jam nut. Strive for equal tension on both chains.
6. Align anchors (1) so each clevis pin (4) is parallel to inner mast.



#### CAUTION

At least 3 full threads must be present below lower nut after adjustment.

7. Tighten jam nuts securely while maintaining alignment of clevis pins.
8. Reconnect the batteries and turn on the keyswitch.
9. Test chain by operating carriage. If slack is still apparent, repeat above procedure.

### 10.2.3 TRIMAST SECONDARY LIFT CHAIN

1. Fully lower the lift carriage.
2. Turn off the key switch and disconnect the batteries.



#### WARNING

Before attempting any adjustment, make certain power is disconnected.

3. Loosen jam nuts, the mount of outer mast, to allow for adjustment of middle jam nut.
4. Break the lower jam nuts, located below the mount of outer mas, free from the middle jam nuts.
5. Take up slack in both lift chains with middle jam nut. Strive for equal tension on both chains.
6. Align anchors so each clevis pin is parallel to the outer mast.



#### CAUTION

At least 3 full threads must be present below lower nut after adjustment.

7. Tighten jam nuts securely while maintaining alignment of clevis pins.
8. Reconnect the batteries and turn on the keyswitch.
9. Test chain by operating carriage. If slack is still apparent, repeat above procedure.

**FIGURE 8-3 MAST (TRIMAST)**

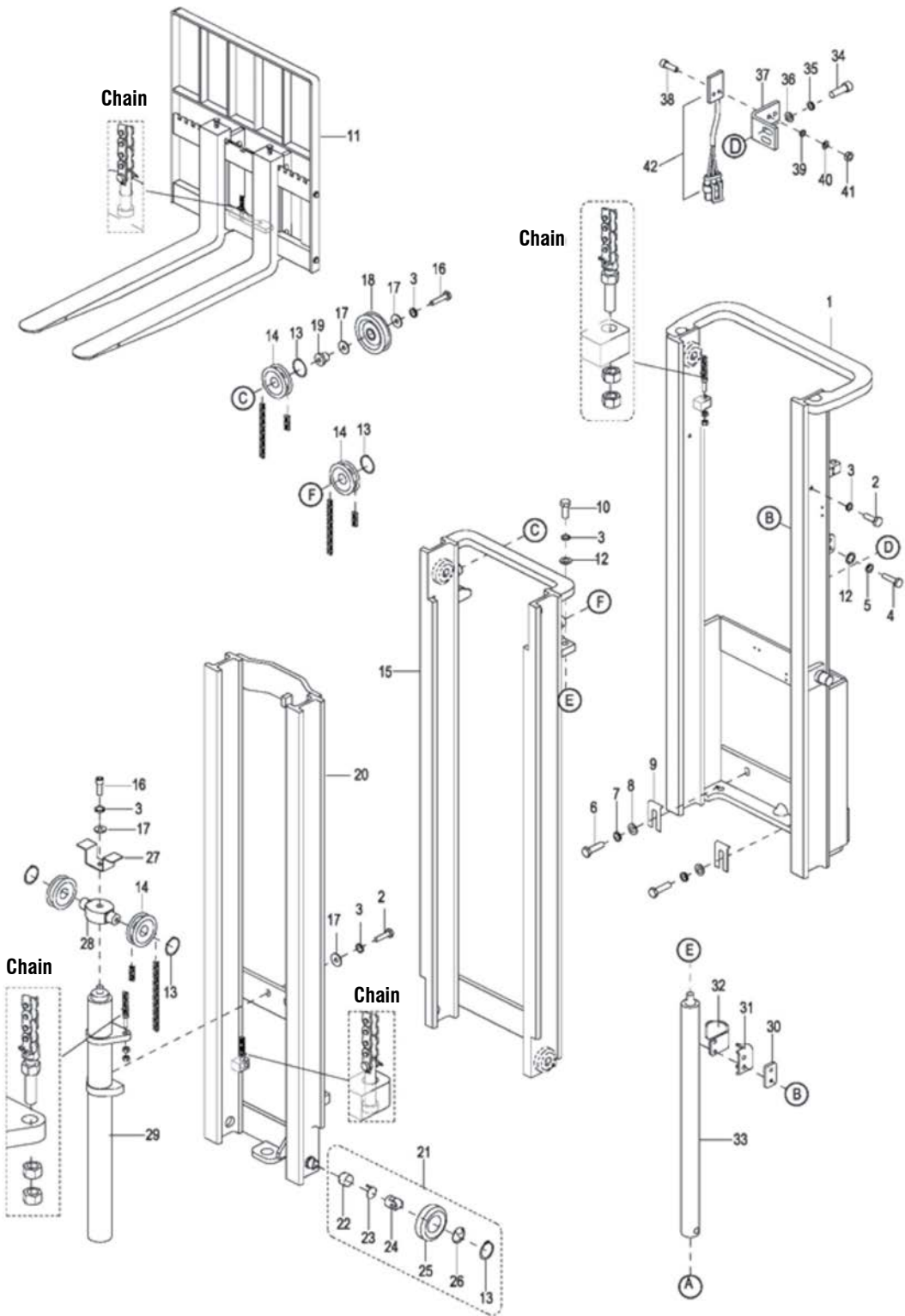

### 10.3 LIFT CHAIN WEAR INSPECTION

Both lift chains should be replaced when either chain is worn enough to increase its length by 3% or more. To make this determination proceed as follows.

Using a section of chain that sees the most frequent operation over the chain sheaves, isolate a vertical portion under tension from the weight of carriage and forks.

Measure the distance between pin centers on 20 vertical links. If the section measures 12.88" or more, the chain should be replaced.

New chain anchor pins should be installed when chains are replaced. Never replace a partial section of chain and never repair chain. Refer to paragraph 9-4. when installing new chain.

### 10.4 LIFT CHAIN REPLACEMENT

#### 10.4.1 TELESCOPIC

1. With the lift truck wheels securely blocked, raise the forks approximately three feet from floor and position blocks or strong supports under inner mast.
2. Lower inner mast onto the support. Check that arrangement is secure before proceeding.
3. Turn off the key switch and disconnect the batteries.



## WARNING

Before attempting any replacement, make certain power is disconnected.

4. Remove cotter pin and clevis pin connecting chain to chain anchor at the lift carriage.
5. Remove cotter pin and clevis pin connecting chain to chain anchor at the outer mast.
6. Remove chain from sheave.
7. Position new chain on sheave.
8. Secure chain to chain anchor at the outer mast with clevis pin and cotter pin.
9. Connect the opposite end of chain to chain anchor at the lift carriage with clevis pin and cotter pin.
10. Adjust the chains according to paragraph 10-2.
11. Reconnect the batteries and turn on the keyswitch.

#### 10.4.2 TRIMAST FREE LIFT CHAIN

1. With the lift truck wheels securely blocked, raise the forks approximately three feet from floor and position blocks or strong supports under the lift carriage.
2. Lower the lift carriage onto the support. Check that arrangement is secure before proceeding.
3. Turn off the key switch and disconnect the batteries.



## WARNING

Before attempting any replacement, make certain power is disconnected.



4. Remove cotter pin and clevis pin connecting chain to chain anchor at the lift carriage.
5. Remove cotter pin and clevis pin connecting chain to chain anchor at free lift cylinder.
6. Remove chain from sheave.
7. Position new chain on sheave.
8. Secure chain to chain anchor at free lift cylinder with clevis pin and cotter pin.
9. Connect the opposite end of chain to chain anchor at the lift carriage with clevis pin and cotter pin.
10. Adjust the chains according to paragraph 10-2.
11. Reconnect the batteries and turn on the keyswitch.

### 10.4.3 TRIMAST SECONDARY LIFT CHAIN

1. With the lift truck wheels securely blocked, raise the forks approximately five feet from floor and position blocks or strong supports under masts.
2. Lower the masts onto the support. Check that arrangement is secure before proceeding.
3. Turn off the key switch and disconnect the batteries.

## WARNING

Before attempting any replacement, make certain power is disconnected.

4. Remove cotter pin and clevis pin connecting chain to chain anchor at inner mast.
5. Remove cotter pin and clevis pin and connecting chain to chain anchor at outer mast.
6. Remove chain from sheave.
7. Position new chain on sheave.
8. Secure chain to chain anchor at outer mast with clevis pin and cotter pin.
9. Connect the opposite end of chain to chain anchor at inner mast with clevis pin and cotter pin.
10. Adjust the chains according to paragraph 10-2.
11. Reconnect the batteries and turn on the keyswitch.

### 10.5 LIFT CYLINDERS

**NOTE:** Removal and repair of lift cylinders are covered in SECTION 11.

## 11.0 HYDRAULIC SYSTEM SERVICING

### 11.1 LINES AND FITTINGS

#### **WARNING**

When forks are raised, pressure exists in the hydraulic system lines and fittings. To ensure release of pressure, forks must be fully lowered and the batteries disconnected before performing any maintenance on the hydraulic system.

**NOTE:** Leaking hydraulic fittings may be remedied by simply tightening fittings. If this does not remedy the leak, the fittings or line must be replaced.

1. Lower forks fully.
2. Turn off the key switch and disconnect the batteries.
3. Remove the compartment covers as described in paragraph 7-3.

#### **CAUTION**

Hydraulic oil can damage parts. Wipe off any oil immediately. Provide a container under the line or fitting before disconnecting. Telescopic Trucks: Refer to and parts pictures for Hydraulic System (Telescopic) trucks and remove leaking line or fitting and replace it with a new line or fitting.

**Telescopic Trucks:** Refer to and parts pictures for Hydraulic System (Telescopic) trucks and remove leaking line or fitting and replace it with a new line or fitting.  
**TRIMAST Trucks:** Hydraulic System (TRIMAST) trucks and remove leaking line or fitting and replace it with a new line or fitting.

4. Check level of hydraulic oil. If required, add hydraulic oil to bring to proper level. Use hydraulic oil listed in **Table 3-2**.
5. Reconnect the batteries and turn on the keyswitch (**14, Figure 12-42** or **14, Figure 12-43**).
6. Operate the lift and lower buttons to refill the cylinder and lines with hydraulic oil.
7. Check level of hydraulic oil. If required, add hydraulic oil to bring to proper level. Use hydraulic oil listed in **Table 3-2**.
8. Install the compartment covers as described in paragraph 5-3.

### 11.2 HYDRAULIC PUMP, MOTOR, AND RESERVOIR ASSEMBLY

The hydraulic pump / motor assembly can be disassembled and repaired. However, a defective pump, valve or motor requires replacement of that component.

#### **WARNING**

When forks are raised, pressure exists in the hydraulic system lines and fittings. To ensure release of pressure, forks must be fully lowered and the batteries disconnected before performing any maintenance on the hydraulic system.

FIGURE 9-1 HYDRAULIC SYSTEM

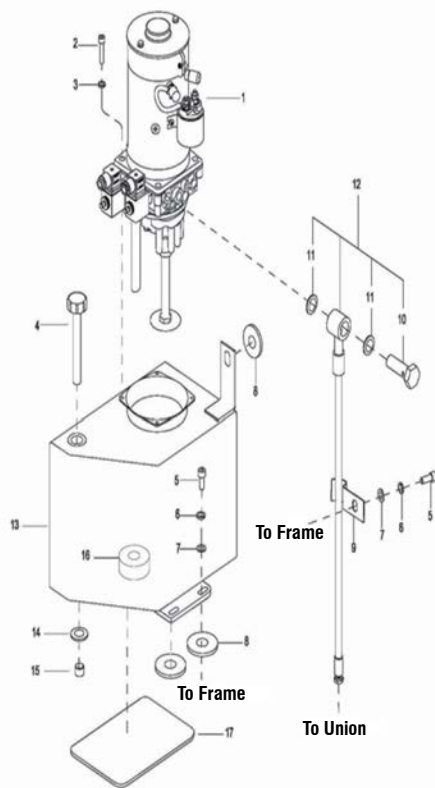

R6819 Hydraulic System (used when not side shift)

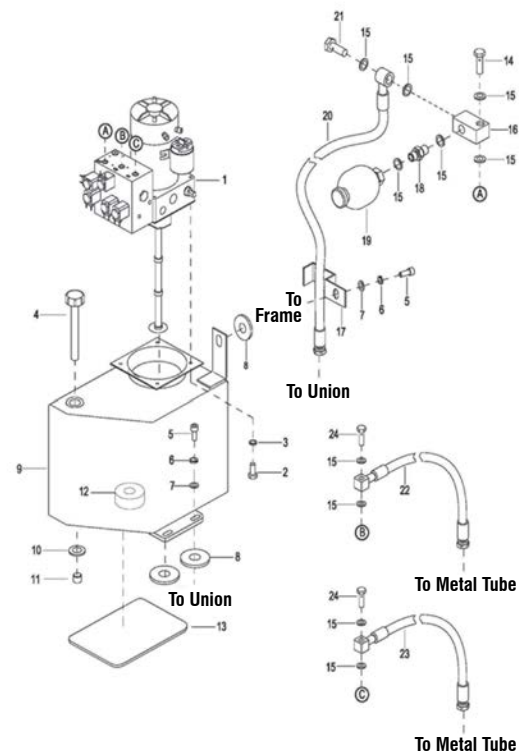

R8058 Hydraulic System (used when Side Shift)

### 11.2.1 REMOVAL

1. Lower forks fully.
2. Turn off the key switch and disconnect the batteries.
3. Remove the compartment covers as described in paragraph 7-3.
4. Tag and disconnect electrical leads from motor and solenoid of pump / motor assembly.

**NOTE:** The reservoir and hose will be filled with hydraulic oil. Place a container under the pump assembly to catch any hydraulic oil.

5. Disconnect hose from pump / motor assembly.
6. While supporting pump / motor assembly remove four screws and four lock washers.
7. Remove the pump / motor assembly (1).

### 11.2.3 INSTALLATION

1. While supporting the pump / motor assembly, install four screws and four lock washers.
2. Reconnect hose to the pump / motor assembly.
3. Connect electrical leads to motor and solenoid of pump / motor assembly.
4. Fill the hydraulic reservoir. Use hydraulic oil listed in **Table 3-2**.
5. Reconnect the batteries and turn on the keyswitch.
6. Operate the lift and lower buttons to refill the cylinder and lines with hydraulic oil.
7. Check level of hydraulic oil. If required, add hydraulic oil to bring to proper level. Use hydraulic oil listed in **Table 3-2**.
8. Install the compartment covers as described in paragraph 7-3.

### 11.2.2 DISASSEMBLY AND REASSEMBLY

1. Remove the hydraulic pump / motor assembly as described in paragraph 11-2.1.
2. Reassemble in reverse order.

## 11.2.4 LIFT CYLINDER (TELESCOPIC)

### 11.2.4.1 REMOVAL

1. With the lift truck wheels securely blocked, raise the forks approximately three feet from floor and position blocks or strong supports under inner mast.
2. Lower inner mast onto the support. Check that arrangement is secure before proceeding.
3. Turn off the key switch and disconnect the batteries.



### WARNING

Before attempting any replacement, make certain power is disconnected.



### CAUTION

Hydraulic oil can damage parts. Wipe off any oil immediately. Provide a container under the line or fitting before disconnecting.

4. Disconnect the hose from the bottom of lift cylinder.
5. Manually push the cylinder rod down as far as possible.



### WARNING

Support lift cylinder before performing the following steps to prevent cylinder from falling.

6. Remove two bolts, two lock washers, two flat washers, clip, bracket and shims.
7. Raise lift cylinder assembly up and out of truck.

### 11.2.4.2 REPAIR



### CAUTION

To prevent damage, use proper pipe clamp vise. The cylinder will be distorted if the vise is tightened too much.

1. Secure the lift cylinder in a vise, clamping lightly at the base of the cylinder.
2. Remove gland nut.
3. Remove wiper ring and O-ring from gland nut.
4. Pull out piston rod.
5. Remove piston and O-ring from rod.
6. Remove guide ring and seal from piston.
7. Coat all parts with hydraulic oil (**Table 3-2**).
8. Install guide ring and new seal on piston.
9. Install new O-ring on rod.
10. Install piston on rod.
11. Insert rod in cylinder tube.
12. Install wiper ring and O-ring on gland nut.
13. Install gland nut in cylinder tube.

**FIGURE 9-2 MAST (TELESCOPIC)**

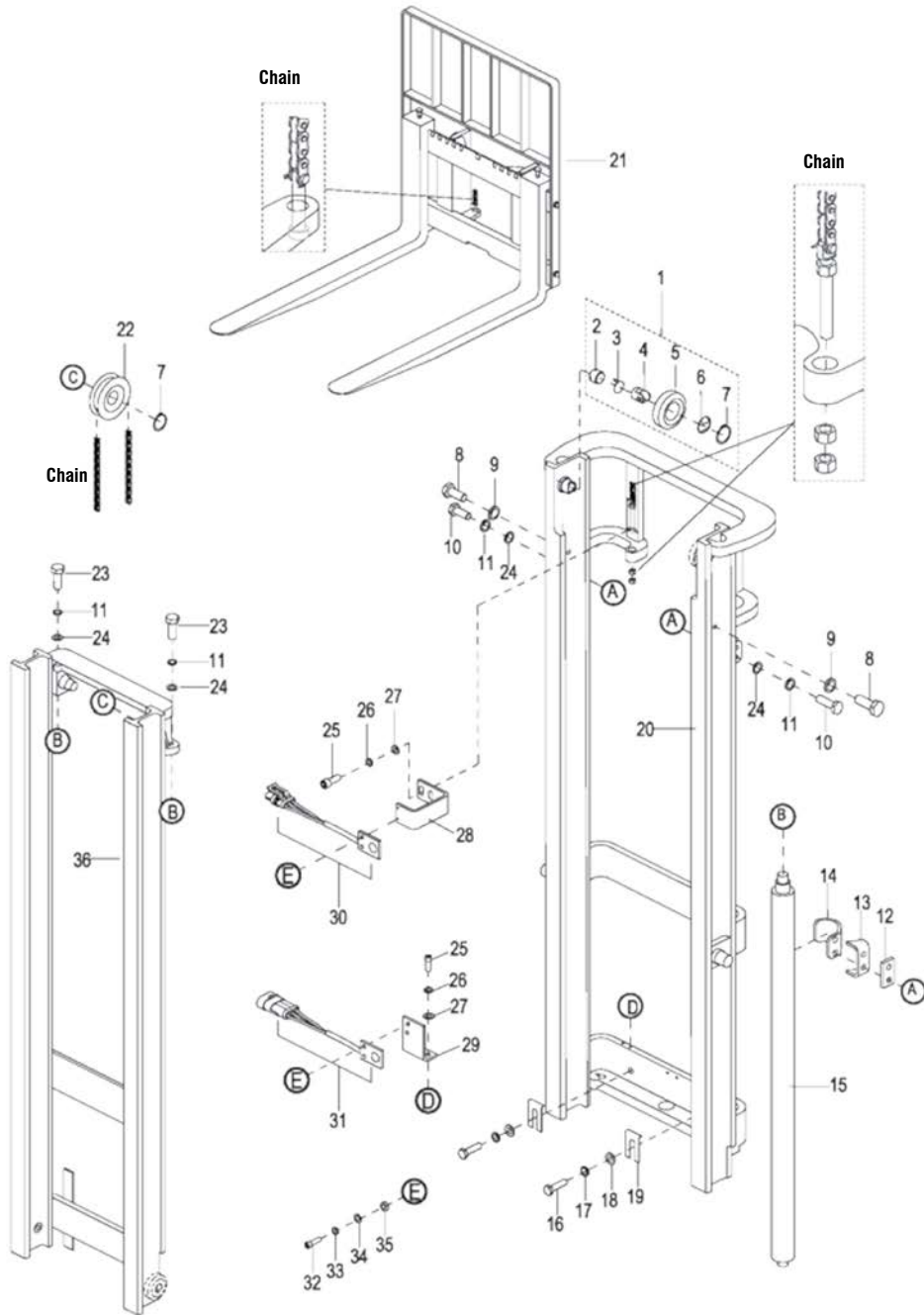

### 11.2.4.3 INSTALLATION

1. Position the cylinder on outer mast.
2. Install clip, bracket and shims and secure with two bolts, two lock washers, two flat washers.
3. Using a suitable lifting device, support the inner mast and remove the supports.
4. Slowly lower the inner mast while lining up the lift cylinder with its mounting taps.
5. Secure the top of the cylinder with screw, lock washer and flat washer.
6. Reconnect the hose to the bottom of lift cylinder.
7. Adjust the chains according to paragraph 10-2.
8. Fill the hydraulic reservoir. Use hydraulic oil listed in **Table 3-2**.
9. Reconnect the batteries and turn on the keyswitch.
10. Operate the lift and lower buttons to refill the cylinder and lines with hydraulic oil.
11. Check level of hydraulic oil. If required, add hydraulic oil to bring to proper level. Use hydraulic oil listed in **Table 3-2**.
12. Install the compartment covers as described in paragraph 7-3.

**FIGURE 9-3 LIFT CYLINDER (TELESCOPIC)**

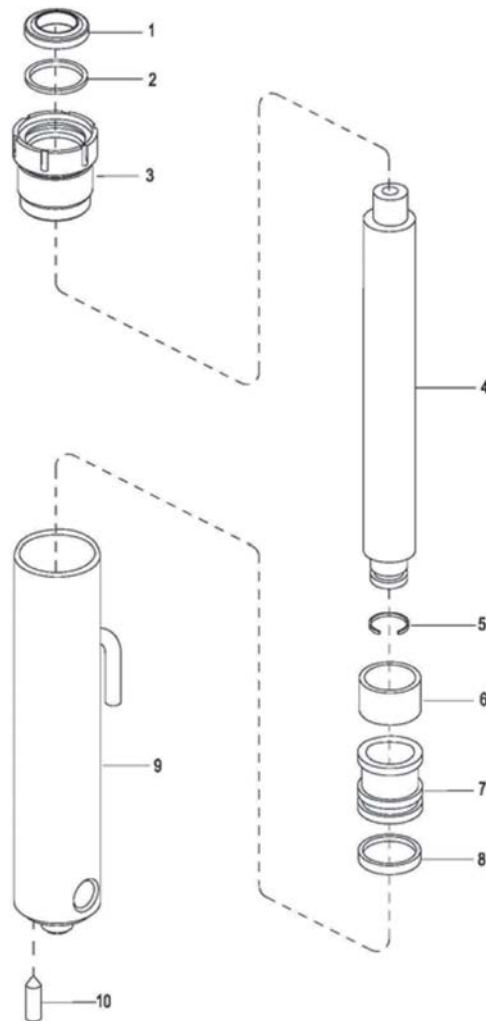

## 11.2.5 LIFT CYLINDER (TRIMAST FREE LIFT)

### 11.2.5.1 REMOVAL

1. Fully lower the lift carriage.
2. Turn off the key switch and disconnect the batteries.

#### WARNING

Before attempting any repairs or replacements, make certain power is disconnected.

3. Using another lift truck or suitable jack, raise lift carriage far enough to remove pressure on the free lift cylinder.
4. Remove cotter pin and clevis pin connecting the lift chain to the anchor at cylinder.
5. Remove chains from sheaves.
6. Remove screw, lock washer, flat washer, bracket and ram head from cylinder.

#### CAUTION

Hydraulic oil can damage parts. Wipe off any oil immediately. Provide a container under the line or fitting before disconnecting.

7. Disconnect the tube from the bottom of lift cylinder.
8. Support cylinder and remove two screws, two lock washers and two flat washers.
9. Raise lift cylinder assembly up and out of truck.

### 11.2.4.2 REPAIR

#### CAUTION

To prevent damage, use proper pipe clamp vise. The cylinder will be distorted if the vise is tightened too much.

1. Secure the lift cylinder in a vise, clamping lightly at the base of the cylinder.
2. Remove gland nut.
3. Remove wiper and O-ring from gland nut.
4. Pull out piston rod.
5. Remove guide ring, snap ring and inner collar from piston rod.
6. Coat all parts with hydraulic oil (**Table 3-2**).
7. Install guide ring, snap ring and inner collar on piston rod.
8. Insert rod in cylinder tube.
9. Install O-ring and wiper on gland nut.
10. Install gland nut in cylinder tube.

### 11.2.5.3 INSTALLATION

1. Position cylinder on inner mast and secure with two screws, two lock washers and two flat washers.
2. Reconnect the tube to the bottom of the cylinder.
3. Position bracket and ram head on cylinder and secure with screw, lock washer, and washer.
4. Position lift chains over sheave and secure lift chain to the anchor at cylinder with clevis pin and cotter pin.
5. Adjust the chains according to paragraph 10-2.
6. Fill the hydraulic reservoir. Use hydraulic oil listed in **Table 3-2**.
7. Reconnect the batteries and turn on the keyswitch.
8. Operate the lift and lower buttons to refill the cylinder and lines with hydraulic oil.
9. Check level of hydraulic oil. If required, add hydraulic oil to bring to proper level. Use hydraulic oil listed in **Table 3-2**.
10. Install the compartment covers as described in paragraph 7-3.

**FIGURE 9-4 MAST (TRIMAST)**

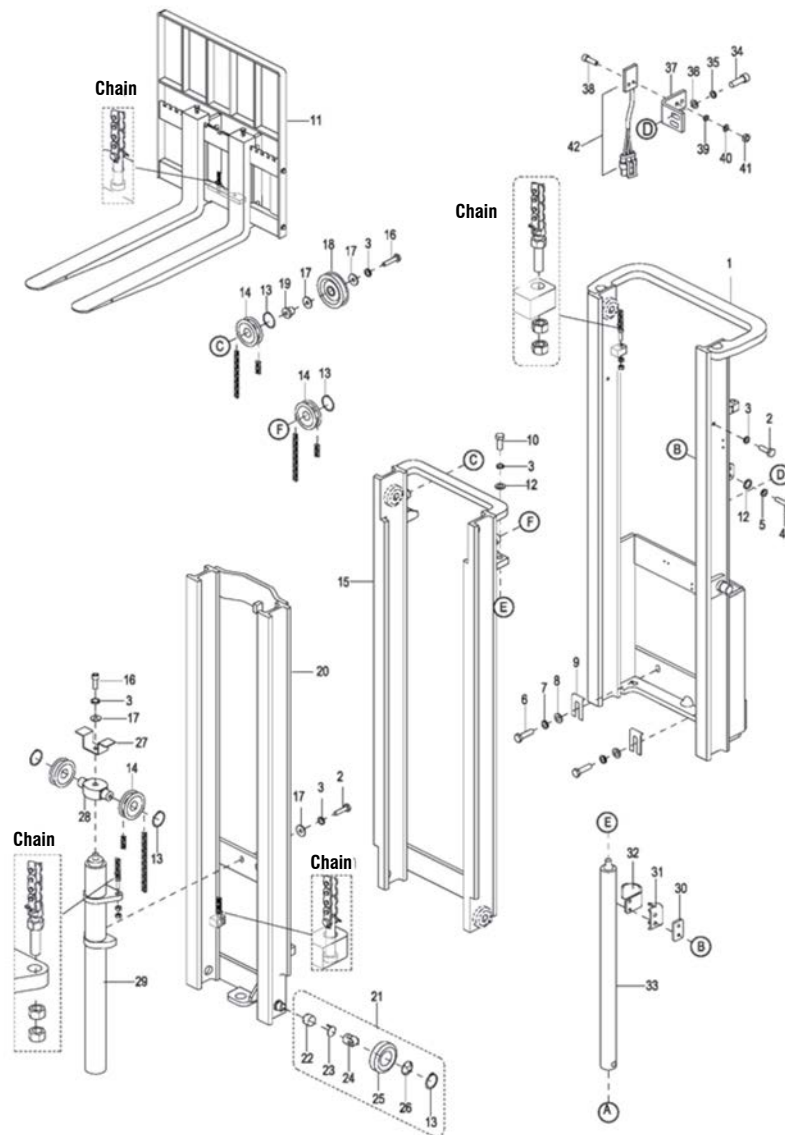
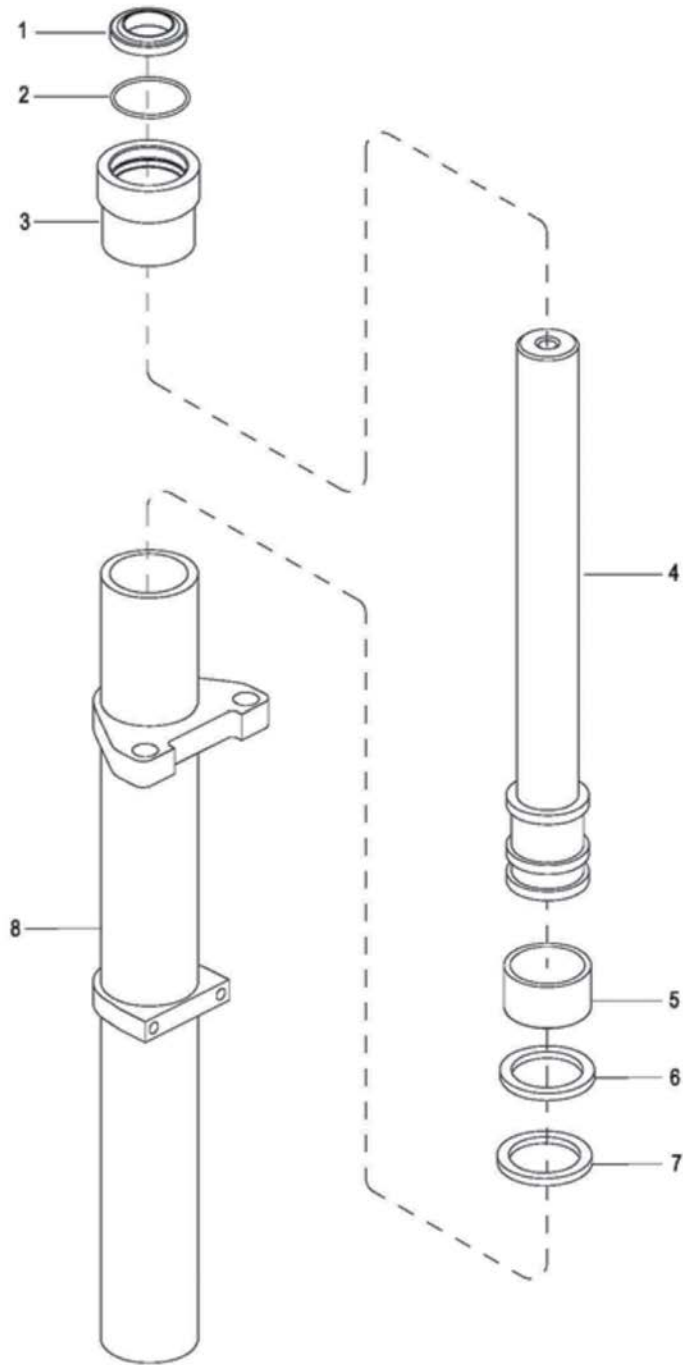



FIGURE 9-5 FREE LIFT CYLINDER (TRIMAST)



## 11.2.6 LIFT CYLINDER (TRIMAST SECONDARY)

### 11.2.6.1 REMOVAL

1. Fully lower the lift carriage.
2. Turn off the key switch and disconnect the batteries.



### WARNING

Before attempting any replacement, make certain power is disconnected.

3. Remove bolt holding cylinder in place securing the top of cylinder to mast.
4. Using another lift truck or suitable jack, raise middle mast far enough to remove pressure on the secondary lift cylinder.



### CAUTION

Hydraulic oil can damage parts. Wipe off any oil immediately. Provide a container under the line or fitting before disconnecting.

5. Disconnect the tube from the bottom of lift cylinder.
6. Support cylinder and remove two bolts, two lock washers, two flat washers, shims, bracket and clip.
7. Raise lift cylinder assembly up and out of truck.

### 11.2.6.3 INSTALLATION

1. Using another lift truck or suitable jack, raise middle mast far enough to allow installation of the secondary lift cylinder.
2. Slowly lower mast while aligning cylinder with the top on mast.
3. Secure the top of cylinder with flat washer, lock washer and screw.
4. Install clip, bracket, shims, two flat washers, two lock washers, and two bolts.
5. Reconnect the tube to the bottom of the lift cylinder.
6. Fill the hydraulic reservoir. Use hydraulic oil listed in **Table 3-2**.
7. Reconnect the batteries and turn on the keyswitch.
8. Operate the lift and lower buttons to refill the cylinders and lines with hydraulic oil.
9. Check level of hydraulic oil. If required, add hydraulic oil to bring to proper level. Use hydraulic oil listed in **Table 3-2**.
10. Install the compartment covers as described in paragraph 7-3.

### 11.2.4.2 REPAIR



### CAUTION

To prevent damage, use proper pipe clamp vise. The cylinder will be distorted if the vise is tightened too much.

1. Secure the lift cylinder in a vise, clamping lightly at the base of the cylinder.
2. Remove gland nut.
3. Remove wiper and O-ring from gland nut.
4. Pull out piston rod.
5. Remove piston and O-ring from piston rod.
6. Remove ring and seal from piston.
7. Coat all parts with hydraulic oil (**Table 3-2**).
8. Install ring and seal on piston.
9. Install piston and O-ring on piston rod.
10. Insert rod in cylinder tube.
11. Install wiper and O-ring on gland nut.
12. Install gland nut in cylinder tube.

FIGURE 9-6 SECONDARY LIFT CYLINDER (TRIMAST)

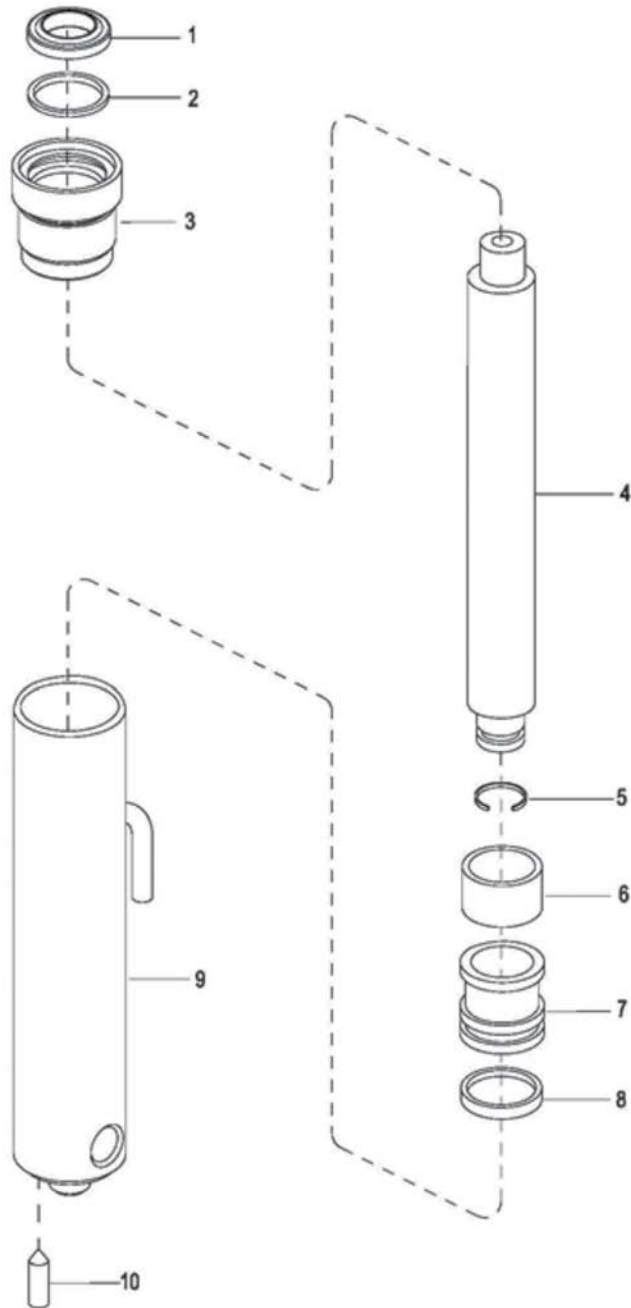

## 12.0 ELECTRICAL COMPONENTS

### 12.1 ELECTRICAL CONTROL PANEL

#### 12.1.1 MAINTENANCE

**NOTE:** Erratic operation of the truck may be caused by defective controller components. Before removing the electrical panel, perform troubleshooting procedures per SECTION 6, to determine corrective action to be taken.

There are no user-serviceable parts inside the controller. No attempt should be made to open the controller. Opening the controller may damage it and will void the warranty.

The controller is programmed at the factory specifically for the truck model on which it is equipped. It is important to replace the controller with the correct preprogrammed unit to assure proper performance settings intended for that particular truck. See **Figure 12-44** for the preprogrammed controller number.

It is recommended that the controller exterior be cleaned periodically, and if a Zapi Handset is available, this periodic cleaning provides a good opportunity to check the controller's diagnostic history file. It is also recommended that the controller's fault detection circuitry be checked whenever the vehicle is serviced.

#### 12.1.2 CLEANING

1. Turn off the key switch and disconnect the batteries.
2. Remove the compartment covers as described in paragraph 7-3.
3. Remove any dirt or corrosion from the bus bar area. The controller should be wiped clean with a moist rag. Allow it to dry before reconnecting the battery.
4. Make sure the connections to the buss bars are tight. Use two well insulated wrenches for this task in order to avoid steering the buss bars.

#### 12.1.3 PANEL REMOVAL

1. Turn off the key switch and disconnect the batteries.
2. Remove the compartment covers as described in paragraph 7-3.
3. Tag and disconnect all electrical cables which connect to the control panel.
4. Remove two screws, two washers, two flat washers and control panel.

#### 12.1.4 PANEL DISASSEMBLY

Refer to the parts page for location and identity of the major replacement components mounted on the panel and remove defective parts.

**NOTE:** Contactor is not repairable and must be replaced if defective.

#### 12.1.5 PANEL INSTALLATION

1. Install the control panel and secure with two screws, two washers, two flat washers.
2. Refer to and, connect all electrical cables to the control panel as noted during removal.
3. Install the compartment covers as described in paragraph 7-3.
4. Reconnect the batteries and turn on the keyswitch.

### 12.2 HORN REPLACEMENT

1. Turn off the key switch and disconnect the batteries.
2. Remove the compartment covers as described in paragraph 7-3.
3. Tag and disconnect all electrical connections from horn.
4. Remove screw, lock washer, flat washer, and horn.
5. Install horn and secure with screw, lock washer, flat washer.
6. Install the compartment covers as described in paragraph 7-3.
7. Reconnect the batteries and turn on the keyswitch.

### 12.3 PUMP MOTOR

The pump motor is replaceable but not repairable. Refer to paragraph 11-2.

### 12.4 DRIVE MOTOR

The drive motor exposed surfaces should be cleaned at least once a month to assure proper cooling of motor. Use an air hose to blow dust off of motor surfaces.

#### 12.4.1 MOTOR REMOVAL

1. Remove the brake as described in paragraph 8-1.3.
2. Remove the transmission as described in paragraph 9-2.
3. Remove the eight screws, eight lock washers and eight flat washers.
4. Lift motor from transmission.
5. Remove three screws, three lock washer and plate from the motor.
6. Remove mounting nut and gear from the motor.

#### 12.4.2 MOTOR INSTALLATION

1. Position key gear on the shaft of motor and secure with the mounting nut.
2. Install plate on the motor and secure with three screws and three lock washer.
3. Install drive motor onto transmission. Make sure to align the gears.
4. Reinstall the eight screws, eight lock washers and eight flat washers to secure the motor to the transmission.
5. Install the transmission as described in paragraph 9-2.
6. Reinstall the brake as described in paragraph 8-1.3.

FIGURE 10-1 ELECTRICAL SYSTEM

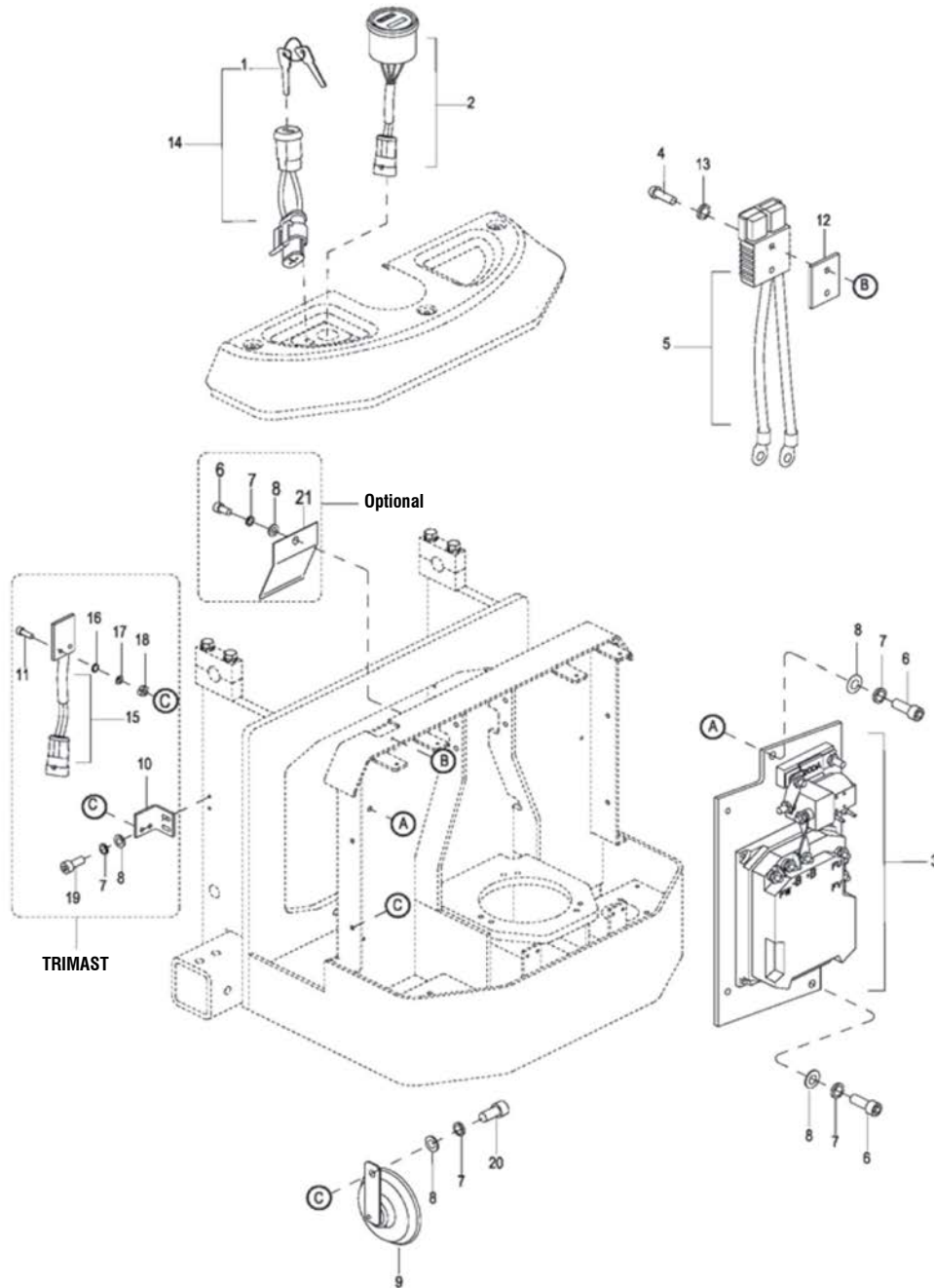

**FIGURE 10-2 ELECTRICAL PANEL**

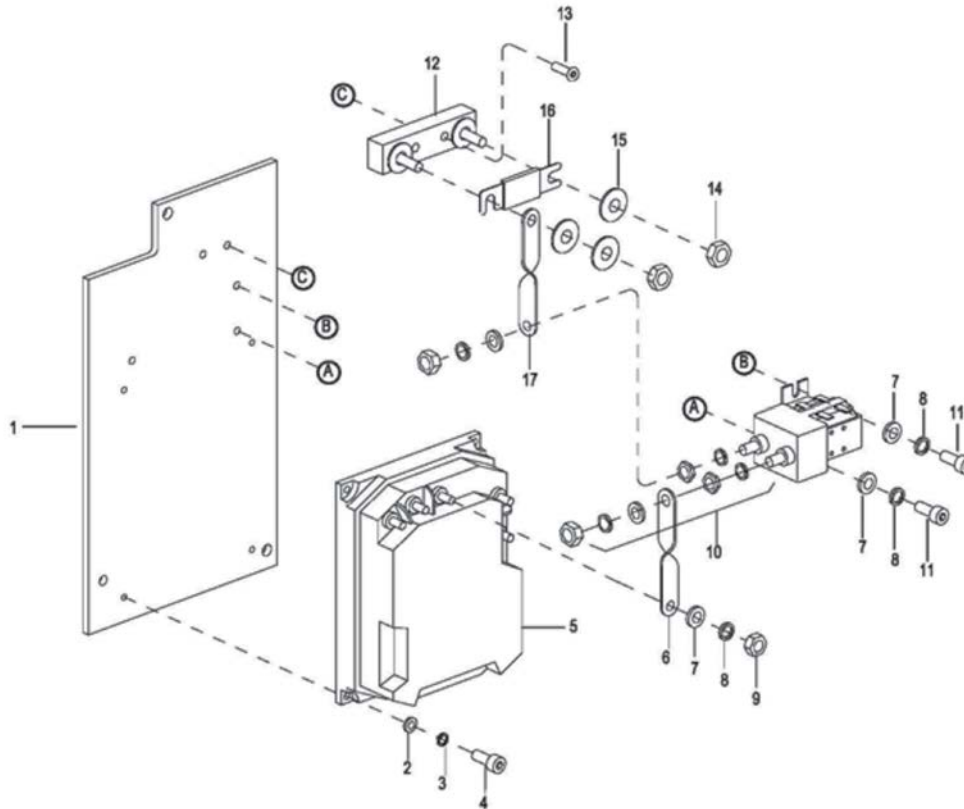

## 12.5 DEADMAN SWITCH

### 12.5.1 REPLACEMENT

1. Position key gear on the shaft of motor and secure with the mounting nut.
2. Install plate on the motor and secure with three screws and three lock washer.
3. Install drive motor onto transmission. Make sure to align the gears.
4. Reinstall the eight screws, eight lock washers and eight flat washers to secure the motor to the transmission.
5. Install the transmission as described in paragraph 9-2.
6. Reinstall the brake as described in paragraph 8-1.3.

## 13.0 OPTIONAL EQUIPMENT

### 13.1 LOAD BACKREST

A load backrest is available for addition to the lift truck to allow handling of high loads.

**FIGURE 10-3 TRANSMISSION, MOTOR, BRAKE ASSEMBLY**

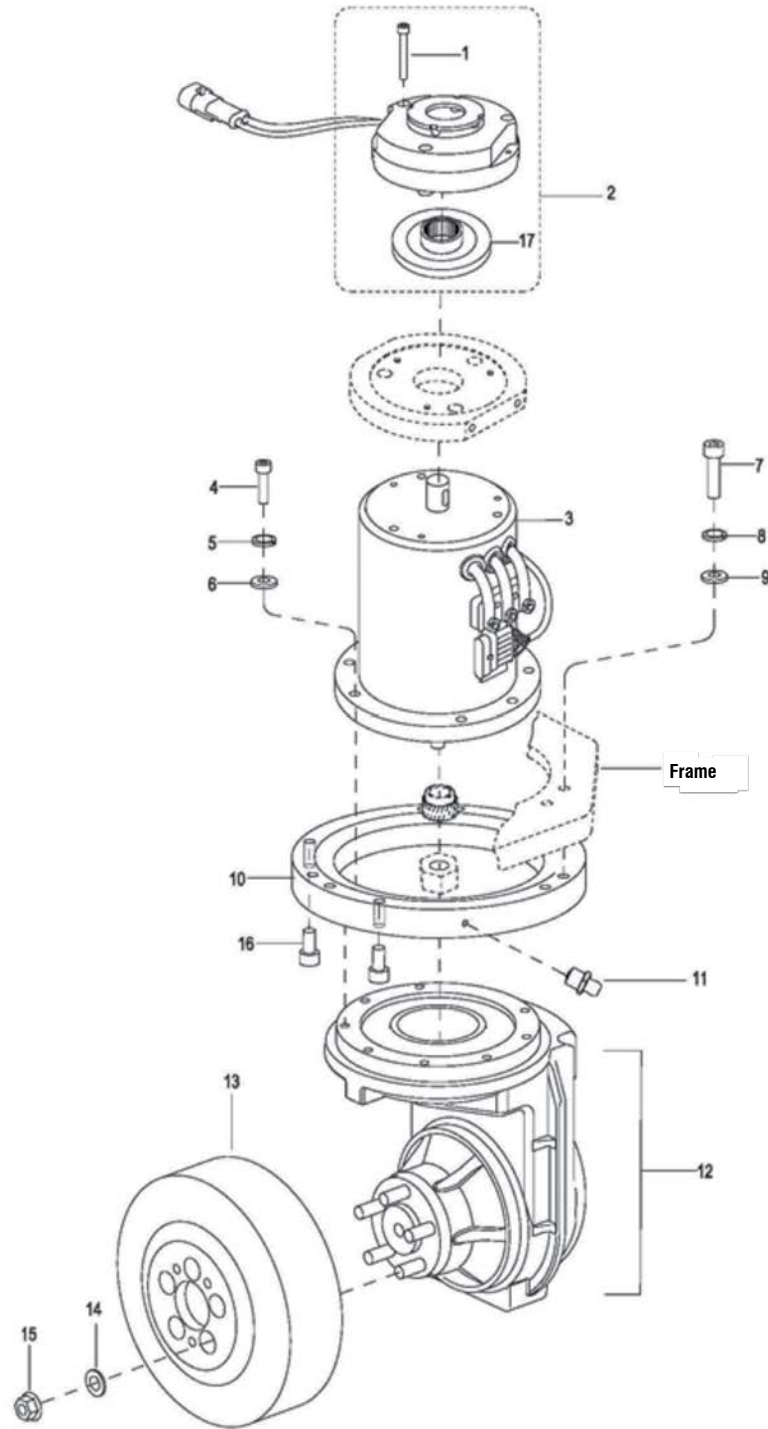

**FIGURE 12-1 STEERING SYSTEM**

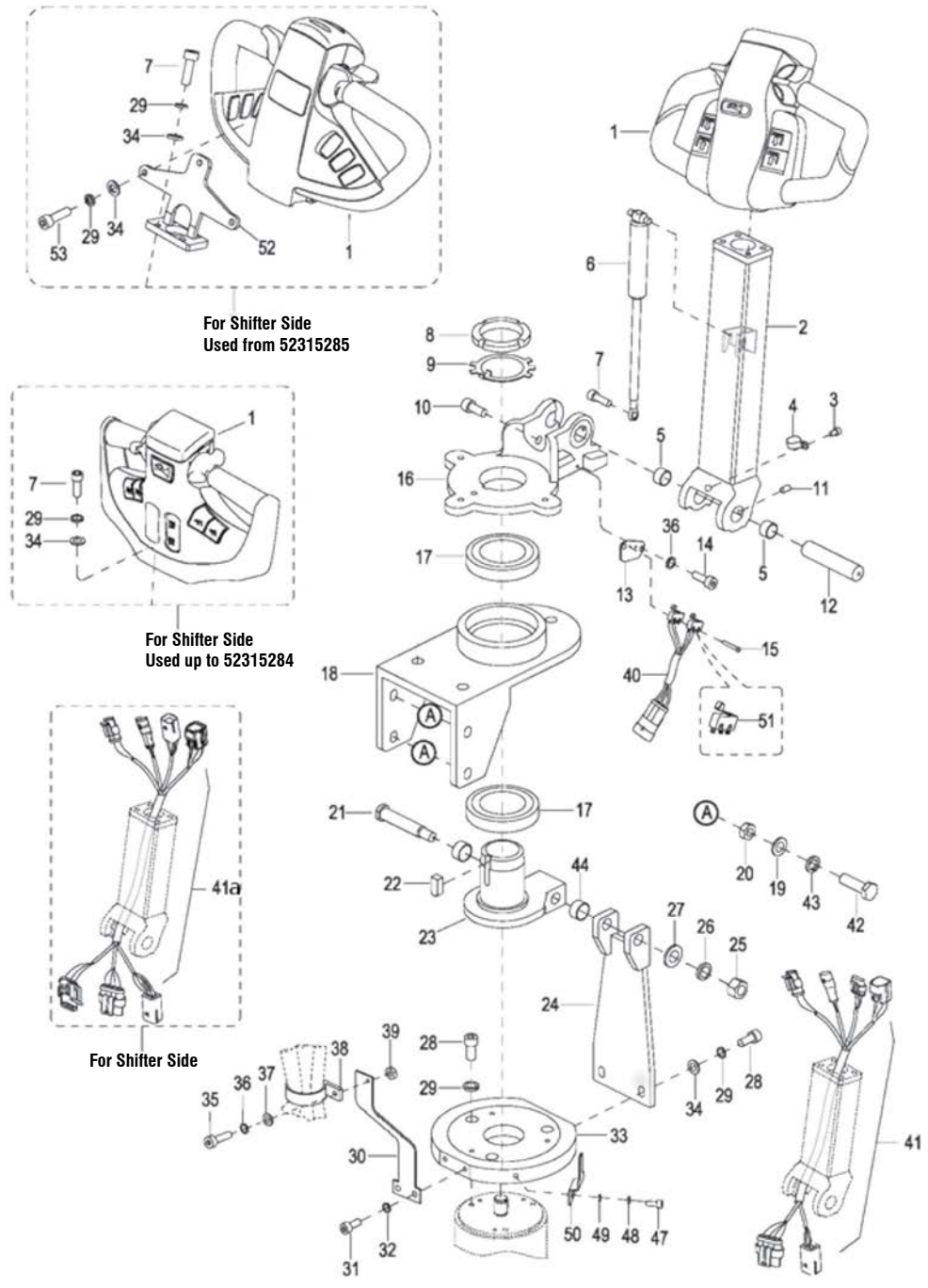



**STEERING SYSTEM**

INDEX NO.	PART NO.	PART NAME	NO. REQ.	NOTES
1	2125-340000-00-B	CONTROL POD ASSEMBLY	1	
1a	1280-360000-10-B	CONTROL POD ASSEMBLY	1	Used when side shift option, up to serial number S2315284
1b	2130-350000-40	CONTROL POD ASSEMBLY	1	Used when side shift option, from serial number S2315285
2	2130-340000-00	CONTROL HANDLE	1	
2a	2130-340000-40	CONTROL HANDLE	1	Used when side shift option, up to serial number S2315284
2b	2130-360000-40	CONTROL HANDLE	1	Used when side shift option, from serial number S2315285
3	0000-000010-00	SCREW M5 x 6	1	
4	0000-000490-00	HARNESS CLAMP	1	
5	0000-000011-00	BEARING 2015	2	
6	2130-350000-00	GAS SPRING	1	
7	0000-000322-00	SCREW M8 x 25	1	
8	0000-000114-00	NUT M52 x 1.5	1	
9	0000-000143-00	CHECK WASHER Ø52 x 1.5	1	
10	0000-000030-00	SCREW M10 x 16	1	
11	0000-000429-00	SCREW M5 x 8	1	
12	1120-300003-00	SHAFT	1	
13	2130-300006-00	SPACER	1	
14	0000-000088-00	SCREW M4 x 8	2	
15	0000-000377-00	SCREW M2 x 20	2	
16	2130-300001-00	TURNING BRACKET	1	
17	0000-000142-00	BEARING	2	
18	2130-330000-00	BRACKET	1	
19	0000-000007-00	FLATWASHER Ø10	4	
20	0000-000553-00	NUT M10	4	
21	1420-300001-00	PIN	1	
22	0000-000735-00	B TYPE KEY 8 x 7 x 14	1	
23	2130-320000-00	BRACKET	1	
24	2130-310000-00	BRACKET	1	

**FIGURE 12-1 STEERING SYSTEM (continued)**

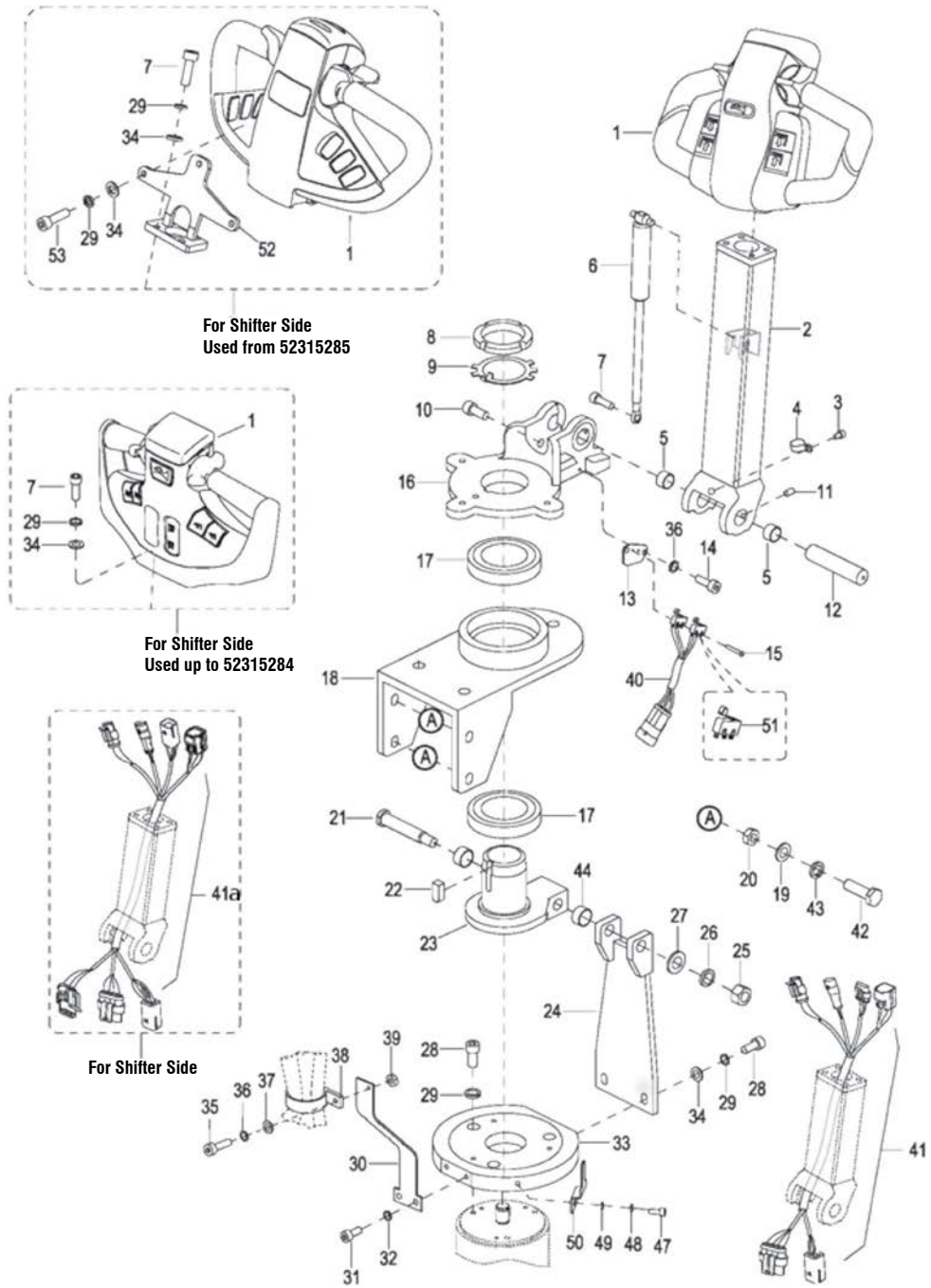

**STEERING SYSTEM (continued)**

INDEX NO.	PART NO.	PART NAME	NO. REQ.	NOTES
24	2130-310000-00	BRACKET	1	
25	0000-000165-00	NUT M12	1	
26	0000-000060-00	LOCKWASHER Ø12	1	
27	0000-000222-00	FLATWASHER Ø12	1	
28	0000-000109-00	SCREW M8 x 16	5	
29	0000-000159-00	LOCKWASHER Ø8	8	
30	1220-300007-00	FIXED PLATE	1	
31	0000-000055-00	SCREW M6 x 16	2	
32	0000-000056-00	LOCKWASHER Ø6	2	
33	1420-300006-00	BRAKE BASE	1	
34	0000-000176-00	FLATWASHER Ø8	5	
35	0000-000378-00	SCREW M4 x 16	1	
36	0000-000122-00	LOCKWASHER Ø4	3	
37	0000-000702-00	FLATWASHER Ø4	1	
38	0000-000491-00	PLASTIC RING	1	
39	0000-000209-00	NUT M4	1	
40	2130-520004-00	WIRE HARNESS -BELLY SWITCH	1	
41	2130-520002-00	WIRE HARNESS	1	
41a	2320-520002-00	WIRE HARNESS	1	Used when Side Shifter
42	0000-000283-00	BOLT M10 x 35	4	
43	0000-000063-00	LOCKWASHER Ø10	4	
44	0000-000011-00	BUSHING	2	
47	0000-000117-00	SCREW M5 x 10	1	
48	0000-000206-00	LOCKWASHER Ø5	1	
49	0000-000390-00	FLATWASHER Ø5	1	
50	1120-300007-00	BRACKET	1	
51	1220-560001-00	INCHING SWITCH I	2	
52	2333-320000-10	CONTROL POD BRACKET	1	Used from serial number S2315285
53	0000-000321-00	SCREW M8 x 20	3	Used from serial number S2315285

**FIGURE 12-2 CONTROL HANDLE ASSEMBLY (not used when side shift)**

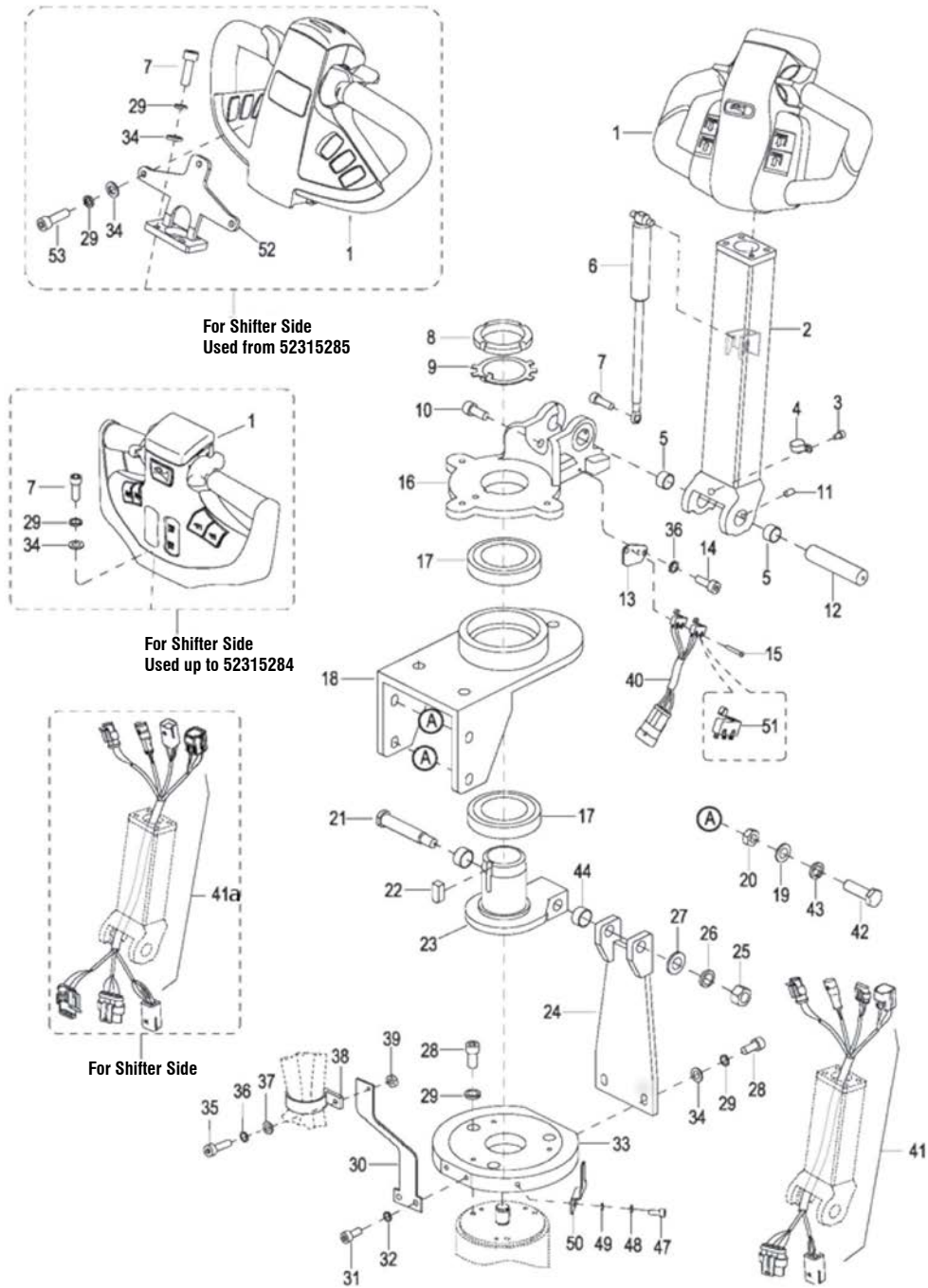

**CONTROL HANDLE ASSEMBLY (not used when side shift)**

INDEX NO.	PART NO.	PART NAME	NO. REQ.	NOTES
1	2125-342000-00-B	CAP ASSEMBLY	1	
2	1120-340005-00	CONTROL KNOB R	1	
3	0000-000038-00	LOCKWASHER Ø3	2	
4	0000-000037-00	SCREW M3 x 12	2	
5	0000-000004-00	SCREW M5 x 12	2	
6	0000-000206-00	LOCKWASHER Ø5	4	
7	0000-000390-00	FLATWASHER Ø5	4	
8	0000-000088-00	SCREW M4 x 8	2	
9	0000-000122-00	LOCKWASHER Ø4	2	
10	0000-000702-00	FLATWASHER Ø4	2	
11	0000-000322-00	SCREW M8 x 25	2	
12	0000-000159-00	LOCKWASHER Ø8	2	
13	0000-000176-00	FLATWASHER Ø8	2	
14	1120-340003-00	CONTROL KNOB L	1	
15	1120-343000-00-B	REVERSING SWITCH ASSEMBLY	1	With Wire
16	0000-000004-00	SCREW M5 x 12	1	
17	0000-000035-00	SCREW M5 x 20	4	
18	1120-340002-00	COVER	1	
19	1120-341000-00	HANDLE	1	
20	1120-340001-00	POD	1	
21	1220-520008-0C	ACCELERATOR HARNESS	1	
22	0000-000010-00	SCREW M5 x 6	1	

FIGURE 12-3 UPPER COVER ASSEMBLY (NOT USED WHEN SIDE SHIFT)

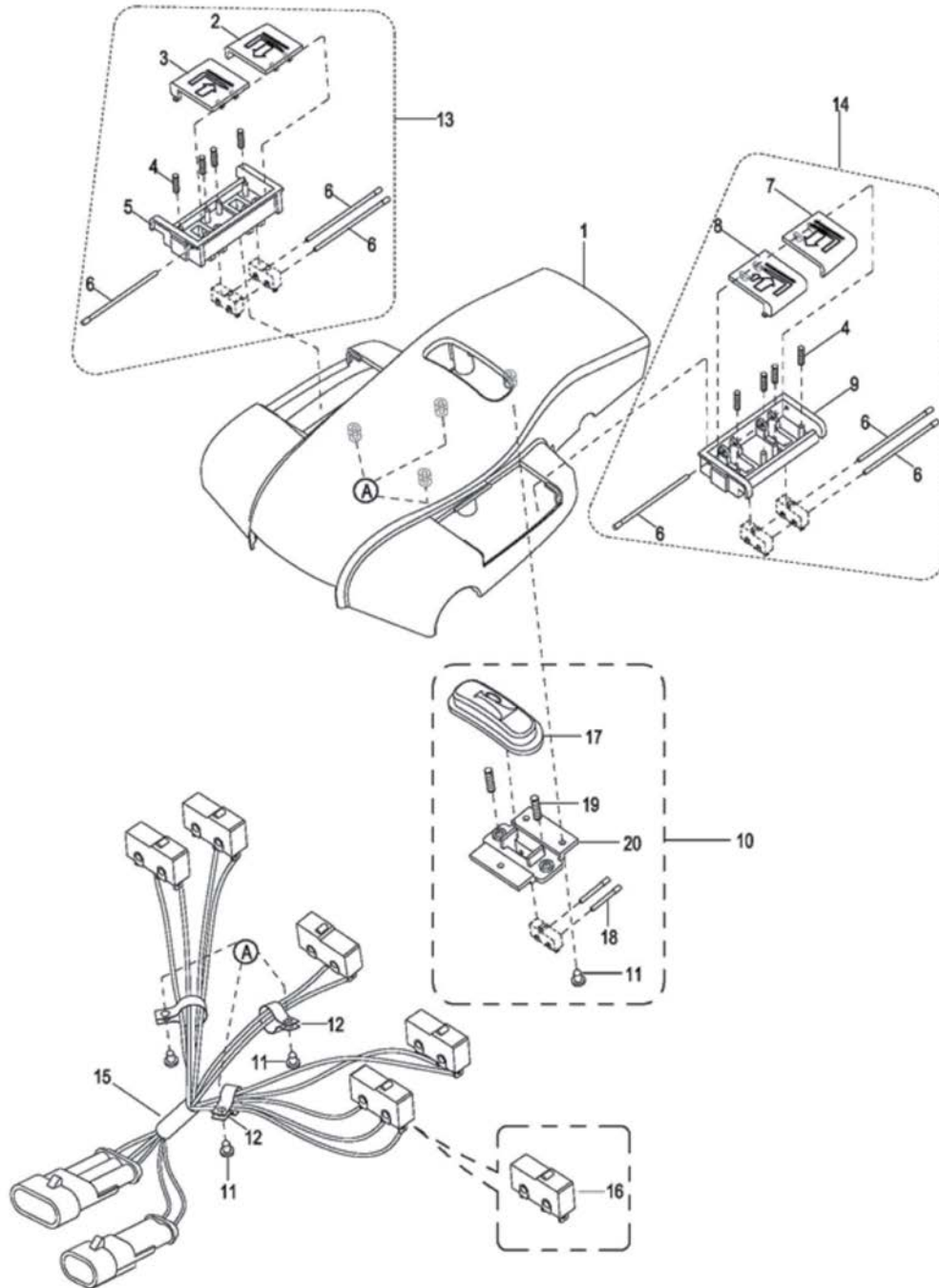

**UPPER COVER ASSEMBLY (not used when side shift)**

INDEX NO.	PART NO.	PART NAME	NO. REQ.	NOTES
1	1120-342001-00	UPPER COVER	1	
2	1120-342203-00	BUTTON FOR LIFTING (R)	1	
3	1120-342202-00	BUTTON FOR LOWERING (R)	1	
4	1120-342102-00	SPRING	8	
5	1120-342201-00	BUTTON BRACKET (R)	1	
6	1120-342105-00	PIN	6	
7	1120-342104-00	BUTTON FOR LIFTING (L)	1	
8	1120-342103-10	2-SPEED BUTTON FOR LOWERING (L)	1	
9	1120-342101-00	BUTTON BRACKET (L)	1	
10	1120-342300-00	HORN BUTTON ASSEMBLY	1	
11	0000-000039-00	SCREW ST3.5 x 9.5	6	
12	0000-000490-00	LINE CLAMP	3	
13	1120-342200-00	LIFTING AND LOWER BOX (R) ASSEMBLY	1	
14	2125-342100-00	2-SPEED LIFT AND LOWER BOX (L) ASSEMBLY	1	
15	2125-520014-0C	2-SPEED WIRING HARNESS- BUTTONS	1	
16	1220-560002-00	INCHING SWITCH II	5	
17	1120-342002-00	HORN BUTTON	1	
18	1120-342005-00	PIN	2	
19	1120-342003-00	SPRING	2	
20	1120-342004-00	BUTTON BRACKET	1	

FIGURE 12-4 EMERGENCY REVERSE SWITCH ASSEMBLY (NOT USED WHEN SIDE SHIFT)

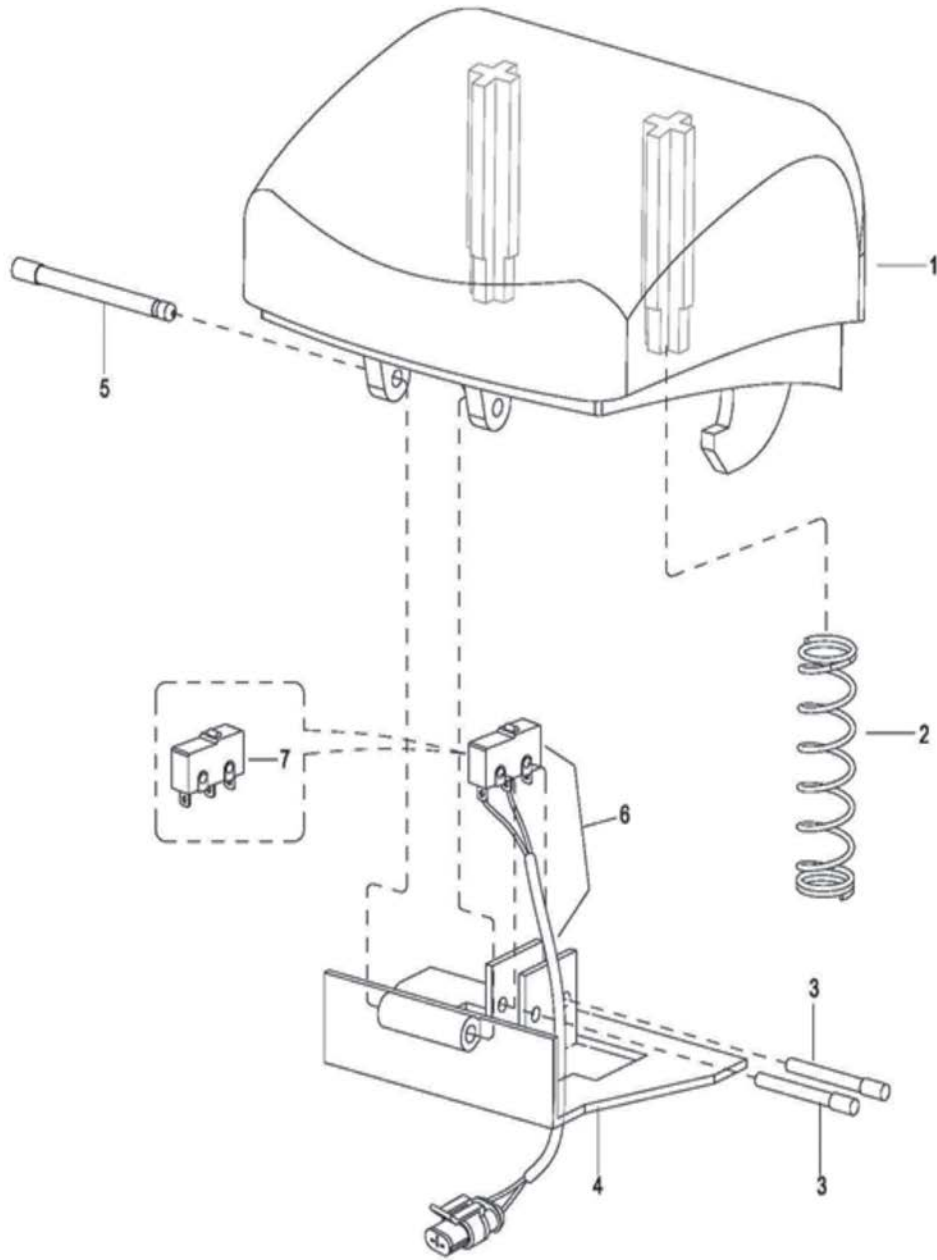



**EMERGENCY REVERSE SWITCH ASSEMBLY (not used when side shift)**

INDEX NO.	PART NO.	PART NAME	NO. REQ.	NOTES
1	1120-343002-00	COVER	1	
2	1120-343003-00	SPRING	2	
3	1120-342005-00	PIN	2	
4	1120-343001-OAE	BRACKET	1	
5	1120-343004-00	PIN	1	
6	1220-520005-00	REVERSING SWITCH WIRE	1	Used up to 12-08-2010
6a	1220-520005-0C	REVERSING SWITCH WIRE	1	Used from 12-09-2010
7	1220-560002-00	NCHING SWITCH II	1	

FIGURE 12-5 CONTROL HEAD ASSEMBLY (FOR SIDE SHIFT) - USED UP TO SERIAL NUMBER S2315284

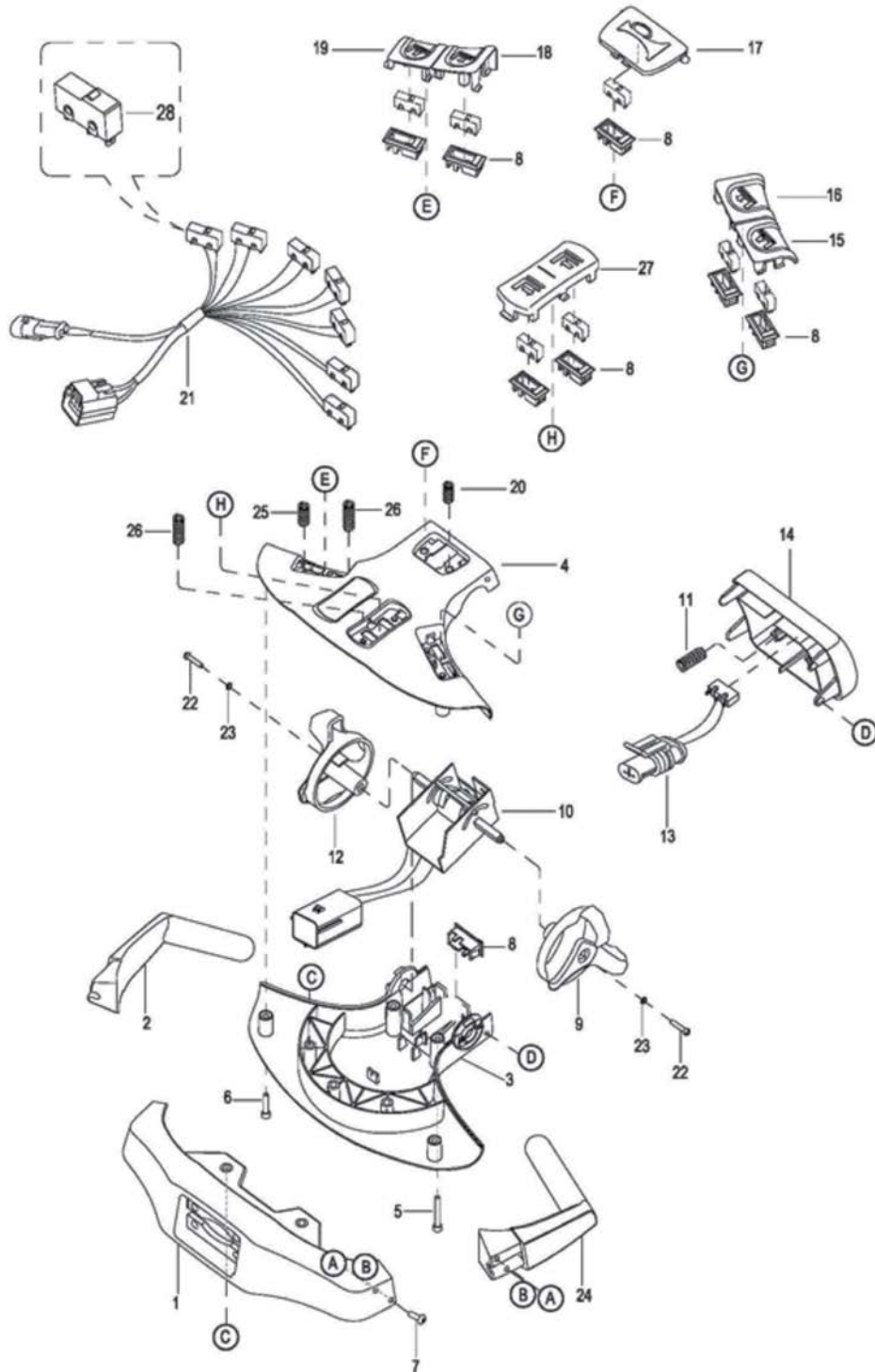

**CONTROL HEAD ASSEMBLY - FOR SIDE SHIFT - USED UP TO SERIAL NUMBER S2315284**

INDEX NO.	PART NO.	PART NAME	NO. REQ.	NOTES
--	1280-360000-10-B	CONTROL POD ASSEMBLY	1	
1	1280-360001-00	BRACKET	1	
2	1280-360002-00	HANDLE R	1	
3	1280-360004-00	COVER	1	
4	1280-360003-00	COVER	1	
5	0000-000320-00	SCREW M6 x 35	2	
6	0000-000032-00	SCREW M6 x 25	2	
7	0000-000498-00	SCREW M6 x 30	4	
8	1280-360013-00	BUTTON BRACKET	6	
9	1280-360006-00	CONTROL KNOB-L	1	
10	1220-520008-0C	WIRE HARNESS-ACCELERATOR	1	
11	1120-343003-00	SPRING	2	
12	1280-360005-00	CONTROL KNOB-R	1	
13	1220-520005-0C	WIRE HARNESS-REVERSING SWITCH	1	
14	1280-360012-00	BUTTON REVERSER	1	
15	1280-360009-00	LOWER BUTTON-L	1	
16	1280-360007-00	LIFTING BUTTON-L	1	
17	1280-360011-00	HORN BUTTON	1	
18	1280-360008-00	LIFTING BUTTON-R	1	
19	1280-360010-00	LOWER BUTTON-R	1	
20	1280-360014-00	SPRING	2	
21	2130-520003-40	WIRE HARNESS-BUTTONS	1	
22	0000-000037-00	SCREW M3 x 12	2	
23	0000-000038-00	LOCKWASHER Ø3	2	
24	1280-360017-00	HANDLE L	1	
25	1280-360015-00	SPRING II	2	
26	1280-360016-00	SPRING I	8	
27	1280-360018-00	SIDESWAY BUTTON	1	
28	1220-560002-00	INCHING SWITCH II	8	

**FIGURE 12-6 CONTROL HEAD ASSEMBLY (FOR SIDE SHIFT) - USED FROM SERIAL NUMBER S2315285**

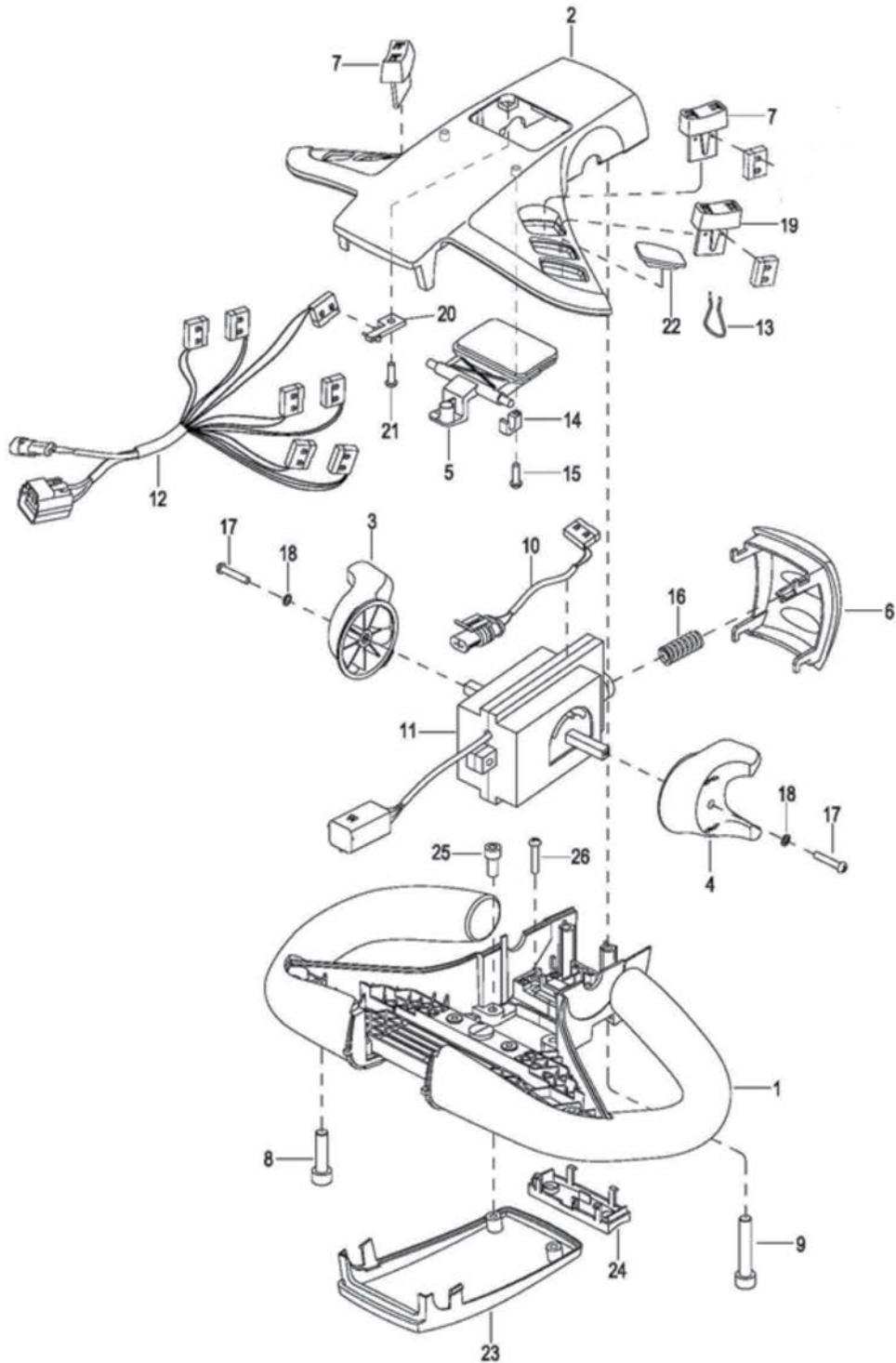

**CONTROL HEAD ASSEMBLY - FOR SIDE SHIFT - USED FROM SERIAL NUMBER S2315285**

INDEX NO.	PART NO.	PART NAME	NO. REQ.	NOTES
1	2333-340001-00	COVER	1	
2	2333-340002-00	CAP	1	
3	2333-340003-00	TRAVELING KNOB R	1	
4	2333-340004-00	TRAVELING KNOB L	1	
5	2333-340005-00	HORN BUTTON	1	
6	2333-340006-00	BUTTON REVERSER COVER	1	
7	2333-340015-00	DIRECTION BUTTON	2	
8	2333-340013-00	SCREW M5 x 30	2	
9	2333-340014-00	SCREW M5 x 55	2	
10	2333-520004-10	REVERSING SWITCH WIRE	1	
11	2333-520003-10	ACCELERATOR ASSEMBLY	1	
12	2130-520003-40	BUTTONS ASSEMBLY	1	
13	2333-340017-00	CLAMP	6	
14	2333-340009-00	MOUNTING SEAT	2	
15	2333-340012-00	SCREW ST2.9 x 9.5	2	
16	2333-340010-00	SPRING	1	
17	0000-000037-00	SCREW M3 x 12	2	
18	0000-000038-00	LOCKWASHER Ø3	2	
19	2333-340016-00	SIDESWAY BUTTON	2	
20	2333-340018-00	BRACKET	1	
21	2333-340019-00	SCREW M3 x 10	1	
22	2333-340020-00	COVER	4	
23	2333-340022-00	SEALING PLATE	1	
24	2333-340023-00	BUTTON	1	
25	2333-340024-00	SCREW M5 x 12	2	
26	2333-340025-00	SCREW ST2.9 x 20	2	

**FIGURE 12-7 TRANSMISSION, MOTOR, BRAKE ASSEMBLY**

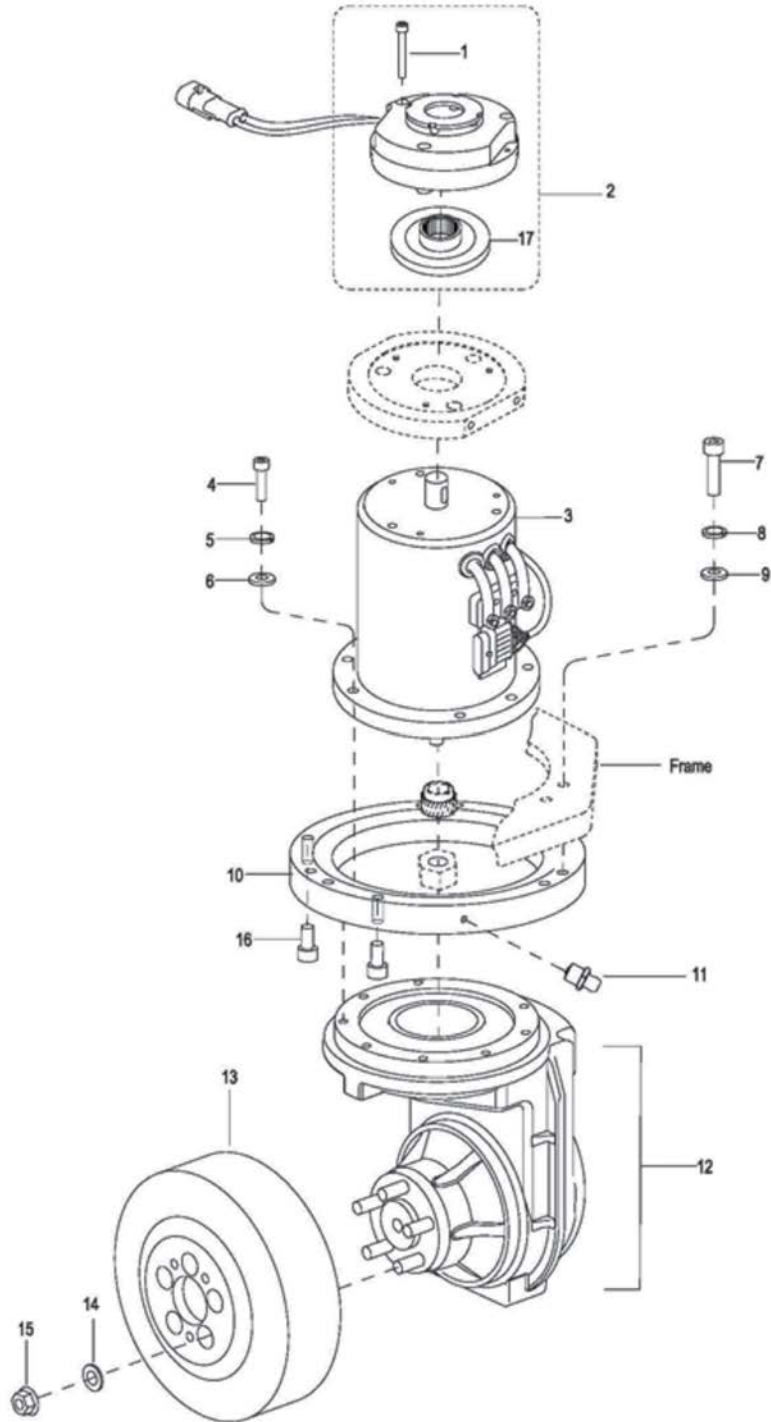

**TRANSMISSION, MOTOR, BRAKE ASSEMBLY**

INDEX NO.	PART NO.	PART NAME	NO. REQ.	NOTES
1	0000-000027-00	SCREW M6 x 55	3	
2	1120-210000-00	BRAKE ASSEMBLY	1	
3	1120-220000-00	MOTOR ASSEMBLY	1	
4	0000-000154-00	SCREW M8 x 35	8	
5	0000-000159-00	LOCKWASHER Ø8	8	
6	0000-000176-00	FLATWASHER Ø8	8	
7	0000-000155-00	SCREW M10 x 40	6	
8	0000-000063-00	LOCKWASHER Ø10	6	
9	0000-000007-00	FLATWASHER Ø10	6	
10	1120-230000-00	BEARING	1	
11	0000-000013-00	GREASE FITTING M8	1	
12	1120-240000-10	GEAR CASE ASSEMBLY III	1	Used up to serial number S2214153 on BGS-30 and S2215044 on BGS-40. This is non serviceable. If replacing a complete gearbox to serviceable part # 1120-240000-30 you have to replace the gear part # 1120-240012-30. Stud for this gearbox is part # 4230-210001-00
12a	1120-240014-00	DRIVE MOTOR GEAR	1	Pictured under the drive motor. This part # is only used for gearbox 1120-240000-10 (pos. # 12)
12b	4230-210001-00	DRIVE WHEEL STUD	5	Used for gearbox 1120-240000-10 (Pos. # 12)
12c	1120-240000-30	GEAR CASE ASSEMBLY IV	1	Used from serial number S2214154 on BGS-30 and S2215045 on BGS-40.
12d	1120-240012-30	DRIVE MOTOR GEAR	1	Used for gearbox 1120-240000-30 (Pos. # 12c)
12e	1120-240014-30	DRIVE WHEEL STUD	5	Used for gearbox 1120-240000-30 (Pos. # 12c)
13	1120-200001-00	DRIVING WHEEL	1	
14	0000-000025-00	LOCKWASHER Ø12	5	
15	0000-000157-00	NUT M12	5	Used for gearbox 1120-240000-30 (Pos. # 12c)
15a	0000-001131-10	NUT M12 x 1.5	5	Used for gearbox 1120-240000-10 (Pos. # 12)
16	0000-000070-00	SCREW M10 x 25	2	
17	1120-210002-00	BRAKE LINING	1	

FIGURE 12-8 TRANSMISSION USED FROM: S2214154 ON BGS-30 AND S2215045 ON BGS-40

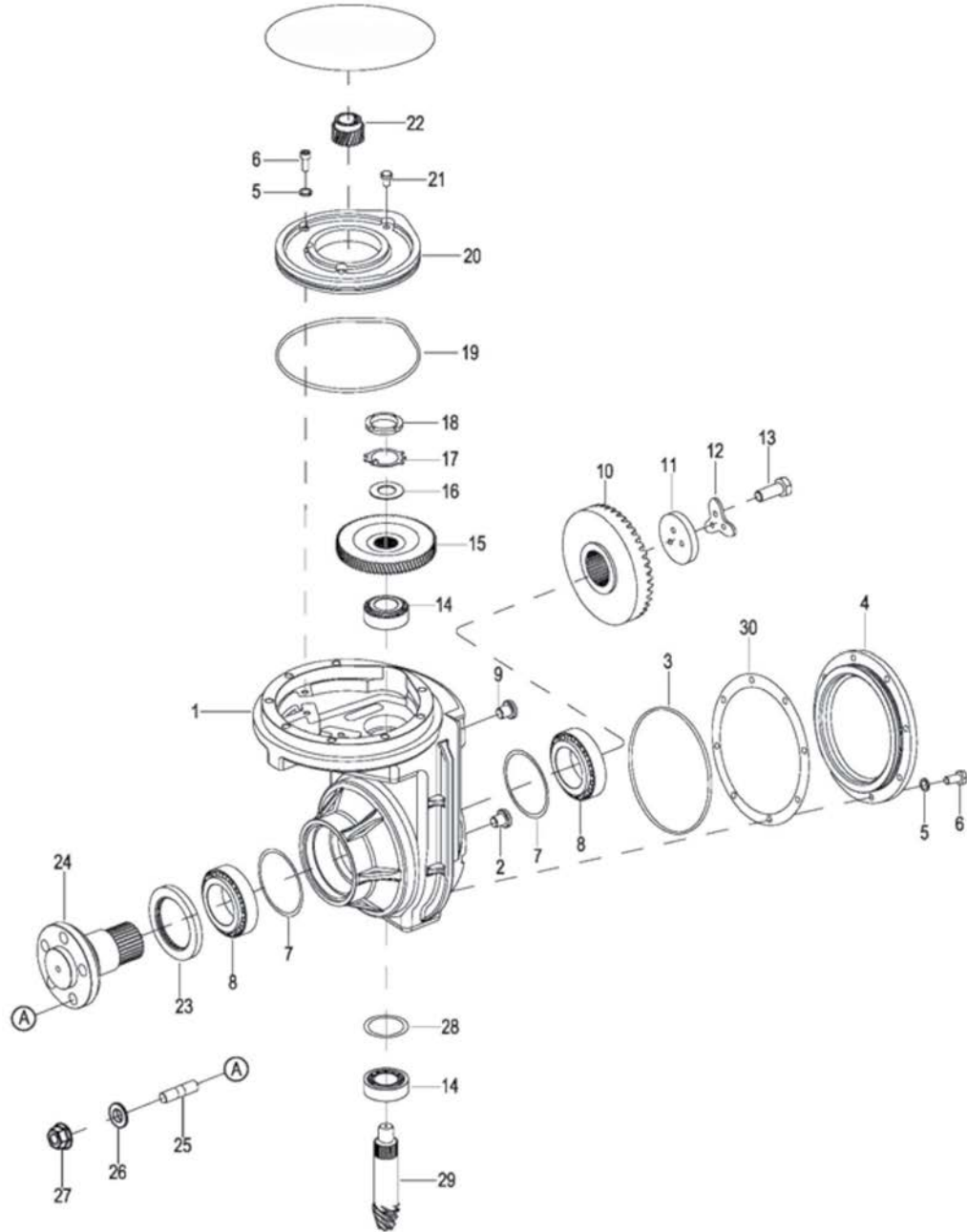



**TRANSMISSION**

INDEX NO.	PART NO.	PART NAME	NO. REQ.	NOTES
--	1120-240000-30	GEARBOX ASSEMBLY	1	
1	1120-240001-30	GEAR CASE	1	
2	1120-240002-30	PLUG	1	
3	0000-000214-00	O-RING 135 x 3.1	1	
4	1120-240003-30	COVER	1	
5	0000-000056-00	LOCKWASHER Ø6	12	
6	0000-000259-00	BOLT M6 x 16	8	
7	1120-240004-30	WASHER	2	
8	0000-000961-00	BEARING	A.R.	As required
9	1120-240005-30	PLUG	1	
10	1120-240006-30	SPIRAL BEVEL GEAR	1	
11	1120-240007-30	WASHER	1	
12	1120-240008-30	LOCKING PLATE	1	
13	0000-000277-00	BOLT M8 x 25	3	
14	0000-001054-00	BEARING	2	
15	1120-240009-30	GEAR	1	
16	0000-000379-00	FLATWASHER Ø14	1	
17	0000-001055-00	WASHER Ø14	1	
18	0000-001056-00	NUT M14 x 1.5	1	
19	0000-000211-00	O-RING 150 x 3.1	1	
20	1120-240010-30	COVER	1	
21	1120-240011-30	PLUG	1	
22	1120-240012-30	GEAR	1	
23	1120-240017-30	SEAL WASHER TC80 x 65 x 8	1	
24	1120-240013-30	OUTPUT SHAFT	1	
25	1120-240014-30	STUDS	5	
26	0000-000025-00	LOCKWASHER Ø12	5	
27	0000-000157-00	NUT M12	5	
28	1120-240015-30	WASHER	A.R.	As required
29	1120-240016-30	GEAR	1	
30	1120-240018-30	WASHER	1	

FIGURE 12-9 COMPARTMENT

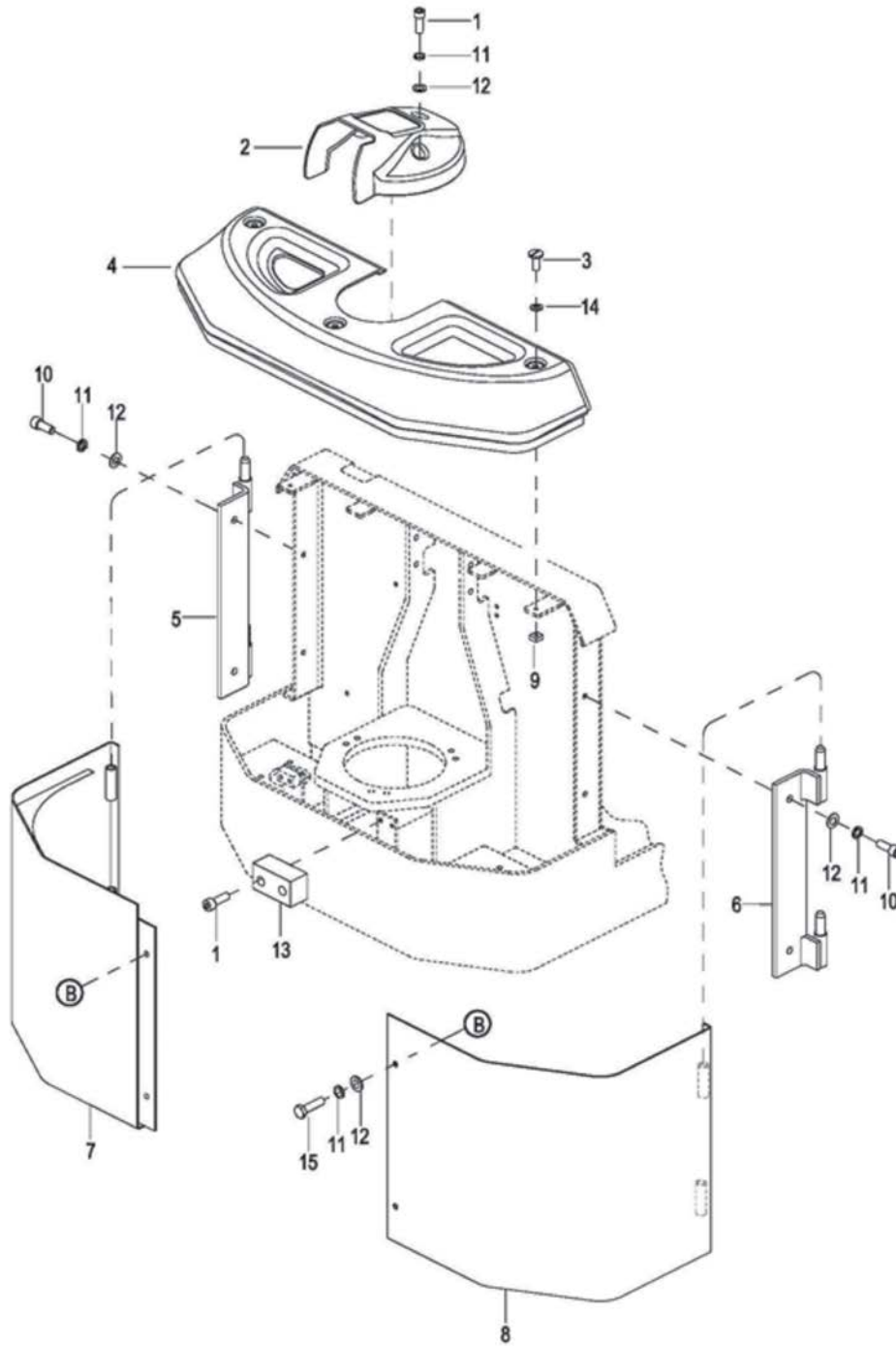

**COMPARTMENT**

INDEX NO.	PART NO.	PART NAME	NO. REQ.	NOTES
1	0000-000433-00	SCREW M8 x 12	7	
2	2130-190002-00	MIDDLE COVER	1	
3	0000-000649-00	SCREW M8 x 20	3	
4	2130-190001-00	UPPER COVER	1	
5	2130-172000-00	BRACKET L	1	
6	2130-182000-00	BRACKET R	1	
7	2130-171000-00	COVER L	1	
8	2130-181000-00	COVER R	1	
9	1220-150005-00	NUT M8	2	
10	0000-000322-00	SCREW M8 x 25	4	
11	0000-000159-00	LOCKWASHER Ø8	9	
12	0000-000194-00	FLATWASHER Ø8	9	
13	2125-600005-00	BUFFER BLOCK	2	
14	2214-150002-00	WASHER	3	
15	0000-000242-00	BOLT M8 x 16	2	

FIGURE 12-10 ADJUSTABLE STRADDLE (BGS-30 ONLY)

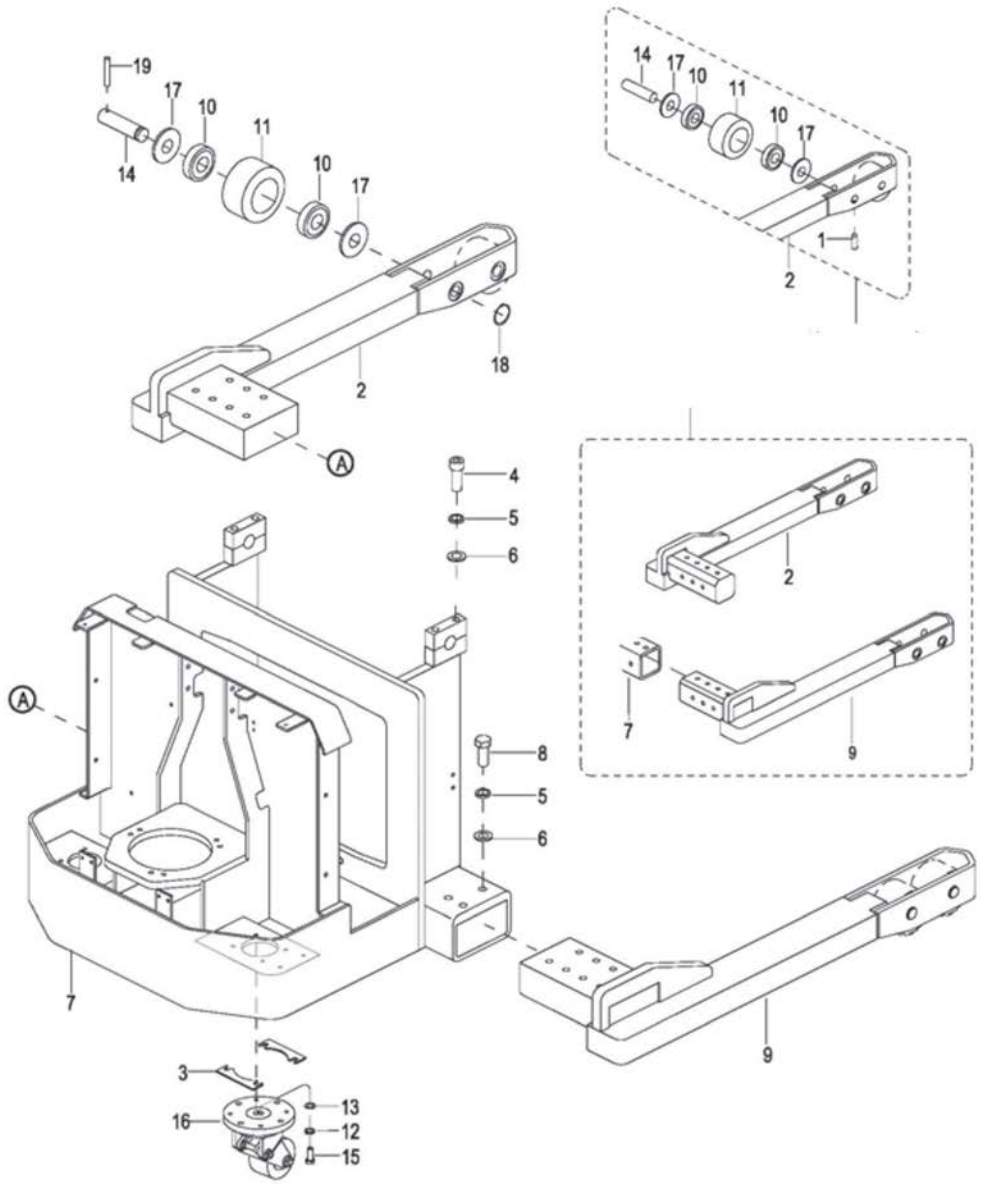

**ADJUSTABLE STRADDLE (BGS-30 only)**

INDEX NO.	PART NO.	PART NAME	NO. REQ.	NOTES
1	0000-000015-00	SCREW M6 x 10	4	Used up to serial number S2020023
2	2130-120000-00	END FRAME L	1	Used up to serial number S2020023, Not when Side Shift
2a	2130-120000-0A	END FRAME L	1	Used from serial number S2020023 to S2118100, Not when Side Shift
2b	2130-120000-0B	END FRAME L	1	Used from serial number S2118101, Not when Side Shift
2c	2130-120000-40	END FRAME L	1	Used when Side Shift option on truck
3	2140-140005-00	WASHER	A.R.	As Requested
4	0000-000432-00	SCREW M16 x 80	4	
5	0000-000191-00	LOCKWASHER Ø16	10	
6	0000-000220-00	FLATWASHER Ø16	10	
7	2130-110000-00	FRAME	1	Used up to serial number S2118100, Not when Side Shift
7a	2130-110000-0A	FRAME	1	Used from serial number S2118101, Not when Side Shift
7b	2130-110000-10	FRAME	1	Used when Telescopic Mast and Side Shift option
7c	2130-110000-40	FRAME	1	Used when TRIMAST and Side Shift option
8	0000-000703-00	BOLT M16 x 45	6	Used up to serial number S2118100
8a	0000-000963-00	BOLT M16 x 60	6	Used from serial number S2118101
9	2130-130000-00	END FRAME R	1	Used up to serial number S2020023
9a	2130-130000-0A	END FRAME R	1	Used from serial number S2020023 to S2118100
9b	2130-130000-0B	END FRAME R	1	Used from serial number S2118101
9c	2130-130000-40	END FRAME R	1	Used when Side Shift option on truck
10	0000-000100-00	BEARING	8	
11	2130-140001-00	LOAD WHEEL	4	
12	0000-000159-00	LOCKWASHER Ø8	8	
13	0000-000176-00	FLATWASHER Ø8	8	

FIGURE 12-10 ADJUSTABLE STRADDLE - BGS-30 ONLY (continued)

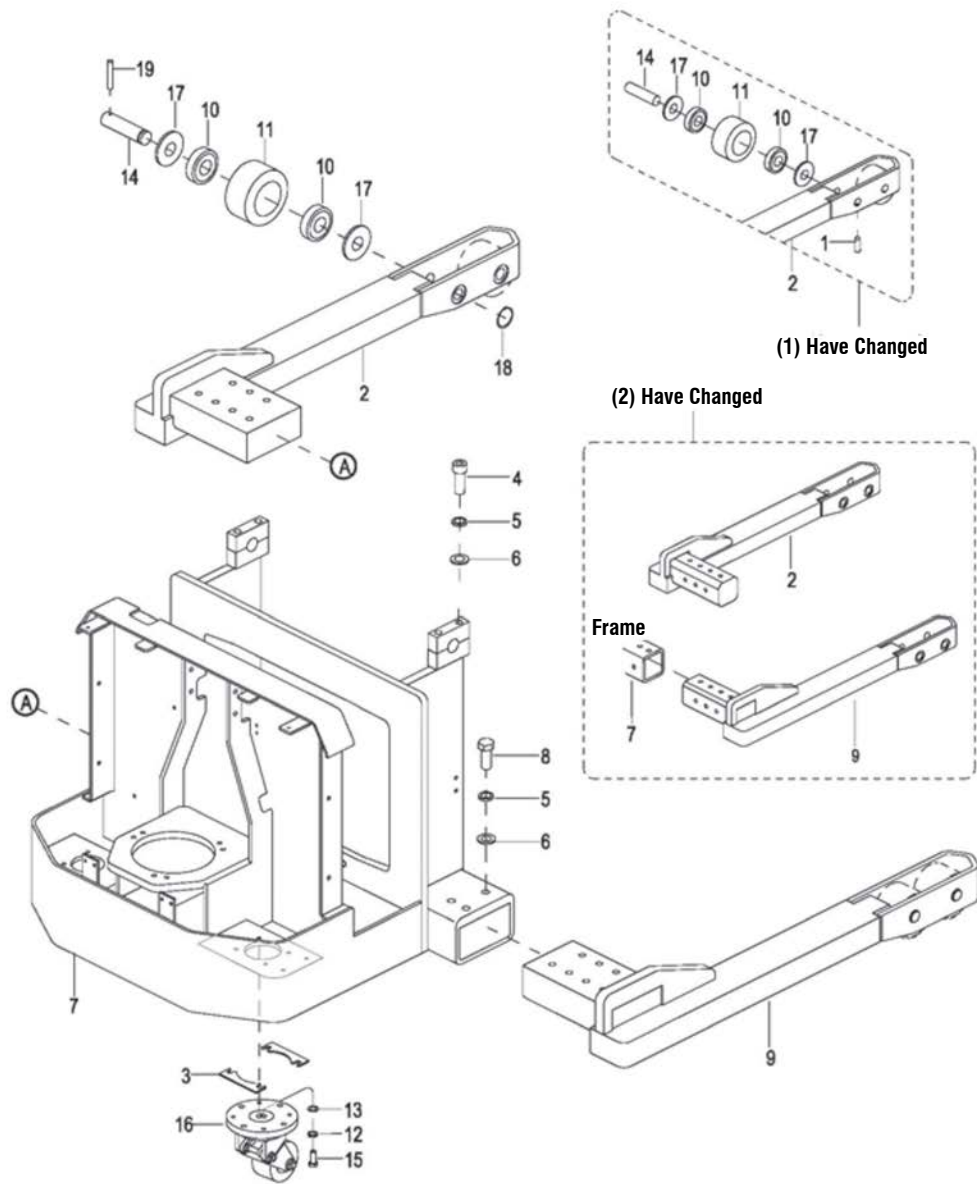

**ADJUSTABLE STRADDLE - BGS-30 ONLY (continued)**

INDEX NO.	PART NO.	PART NAME	NO. REQ.	NOTES
14	2130-140002-00	SHAFT	4	Used up to serial number S2020022
14a	2130-140002-0A	SHAFT	4	Used from serial number S2020023
15	0000-000277-00	BOLT M8 x 25	8	
16	1120-140000-00	CASTER ASSEMBLY I	2	Used up to serial number S2118100
16a	1118-140000-00	CASTER ASSEMBLY I	2	Used from serial number S2118101
17	2130-140003-00	WASHER	8	
18	0000-000294-00	RETAINING RING Ø25	4	Used from 10-17-2011
19	0000-000654-00	ROLL PIN Ø4 x 45	4	Used from 10-17-2011

FIGURE 12-11 FIXED STRADDLE (BGS-40 ONLY)

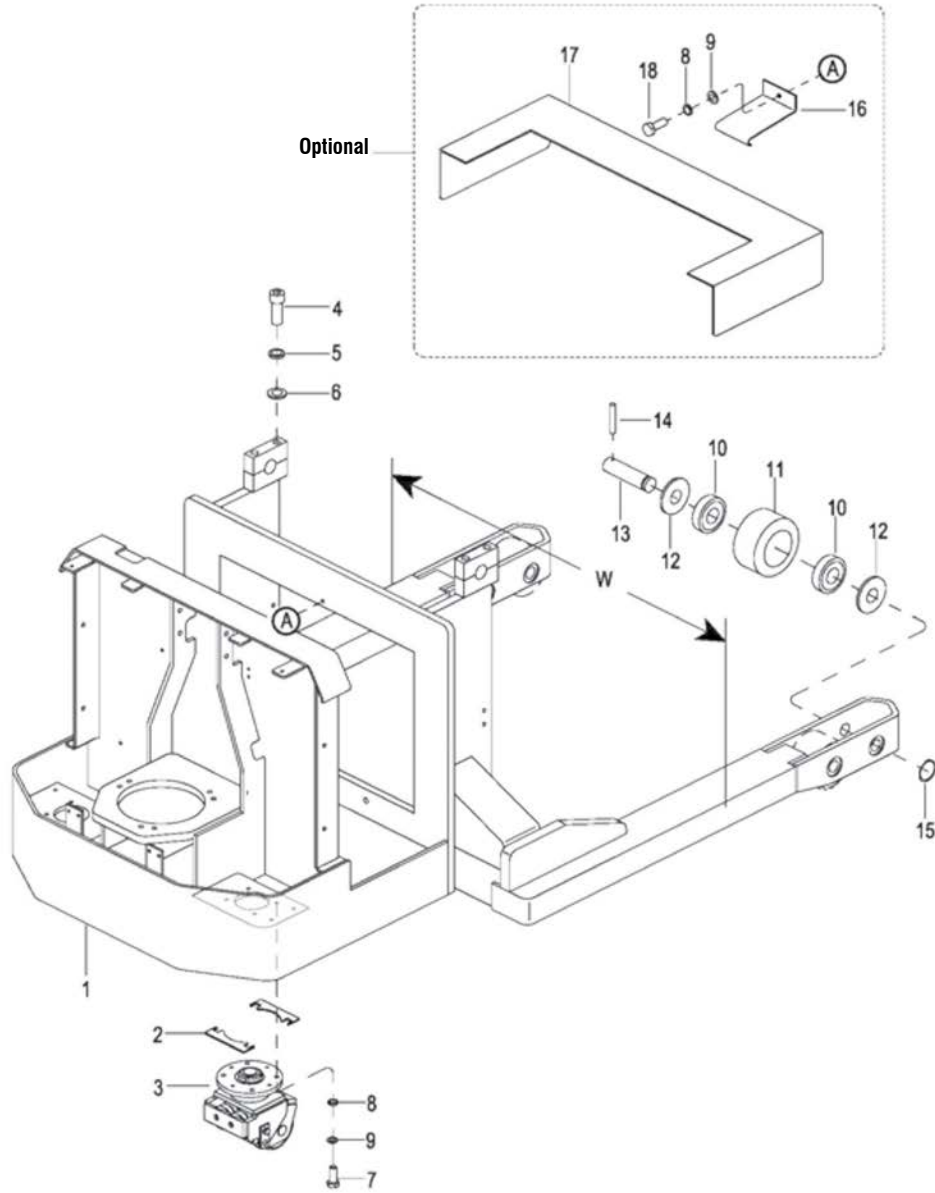



**FIXED STRADDLE (BGS-40 ONLY)**

INDEX NO.	PART NO.	PART NAME	NO. REQ.	NOTES
1	--	FRAME	1	Contact Blue Giant
2	2140-140005-00	WASHER	A.R.	As Required
3	2140-140000-0A	CASTER ASSEMBLY	2	
4	0000-000432-00	SCREW M16 x 80	4	
5	0000-000191-00	LOCKWASHER Ø16	4	
6	0000-000220-00	FLATWASHER Ø16	4	
7	0000-000277-00	BOLT M8 x 25	8	
8	0000-000159-00	LOCKWASHER Ø8	8	
9	0000-000176-00	FLATWASHER Ø8	8	
10	0000-000100-00	BEARING	8	
11	2130-140001-00	LOAD WHEEL	4	
12	2130-140003-00	WASHER	8	
13	2130-140002-0A	SHAFT	4	
14	0000-000654-00	ROLL PIN Ø4 x 45	4	
15	0000-000294-00	RETAINING RING Ø25	4	
16	2140-100002-00	BATTERY CLAMP	1	
17	2140-101000-00	BATTERY CLIP	1	Optional - available from 01-03-2013
18	0000-000242-00	BOLT M8 x 16	1	Optional - available from 01-03-2013

FIGURE 12-12 BATTERY COMPARTMENT

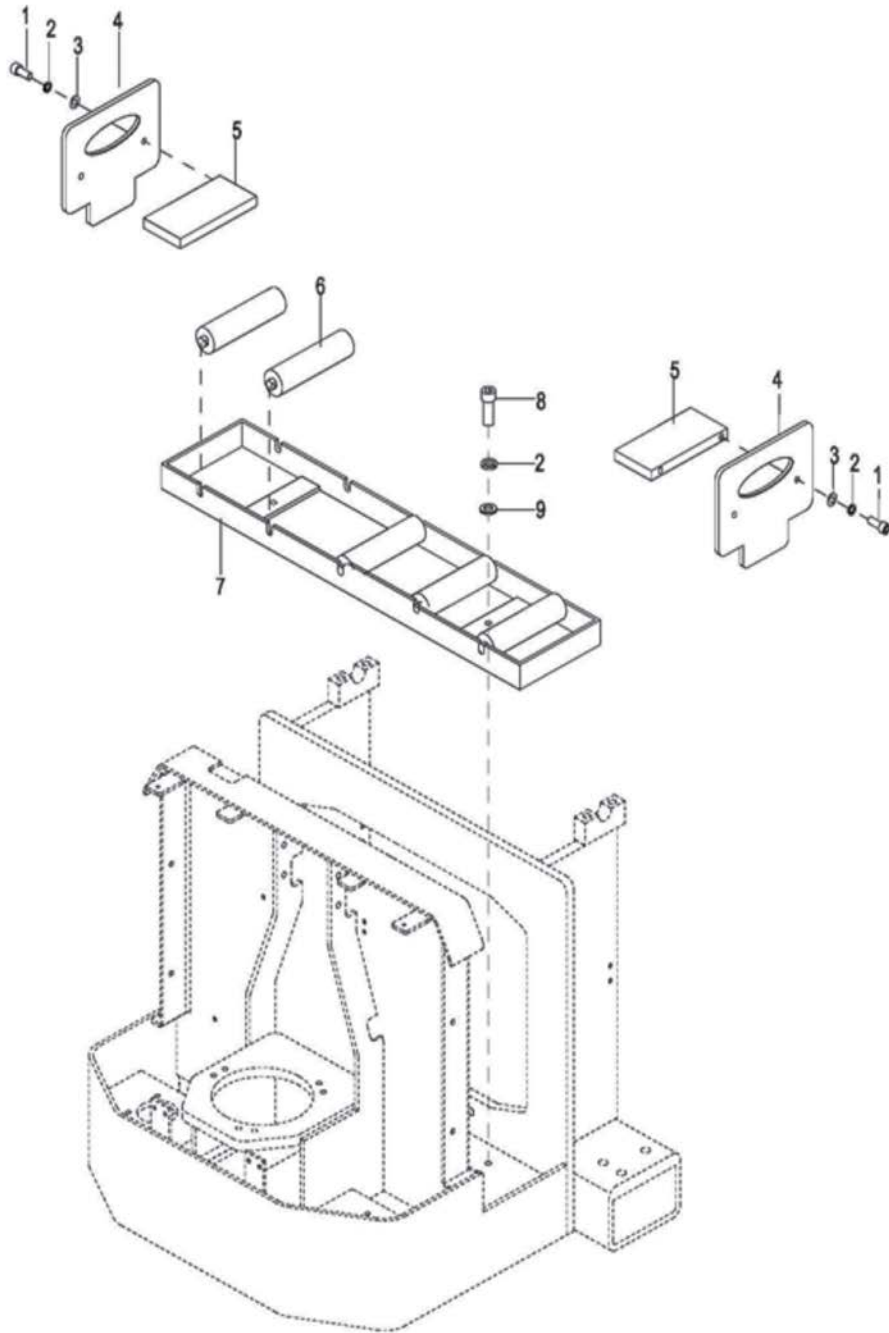

**BATTERY COMPARTMENT**

INDEX NO.	PART NO.	PART NAME	NO. REQ.	NOTES
1	0000-000322-00	SCREW M8 x 25	4	
2	0000-000159-00	LOCKWASHER Ø8	6	
3	0000-000176-00	FLATWASHER Ø8	4	
4	2130-160001-00	BAFFLE-PLATE	2	
5	2130-160002-00	BAFFLE-BLOCK	2	
6	2125-102200-0A	ROLLER	5	Optional
7	2130-151000-00	SLIDEWAY FRAME	1	Optional
8	0000-000321-00	SCREW M8 x 20	2	Optional
9	0000-000194-00	FLATWASHER Ø8	2	Optional

FIGURE 12-13 WINDSHIELD (TELESCOPIC)

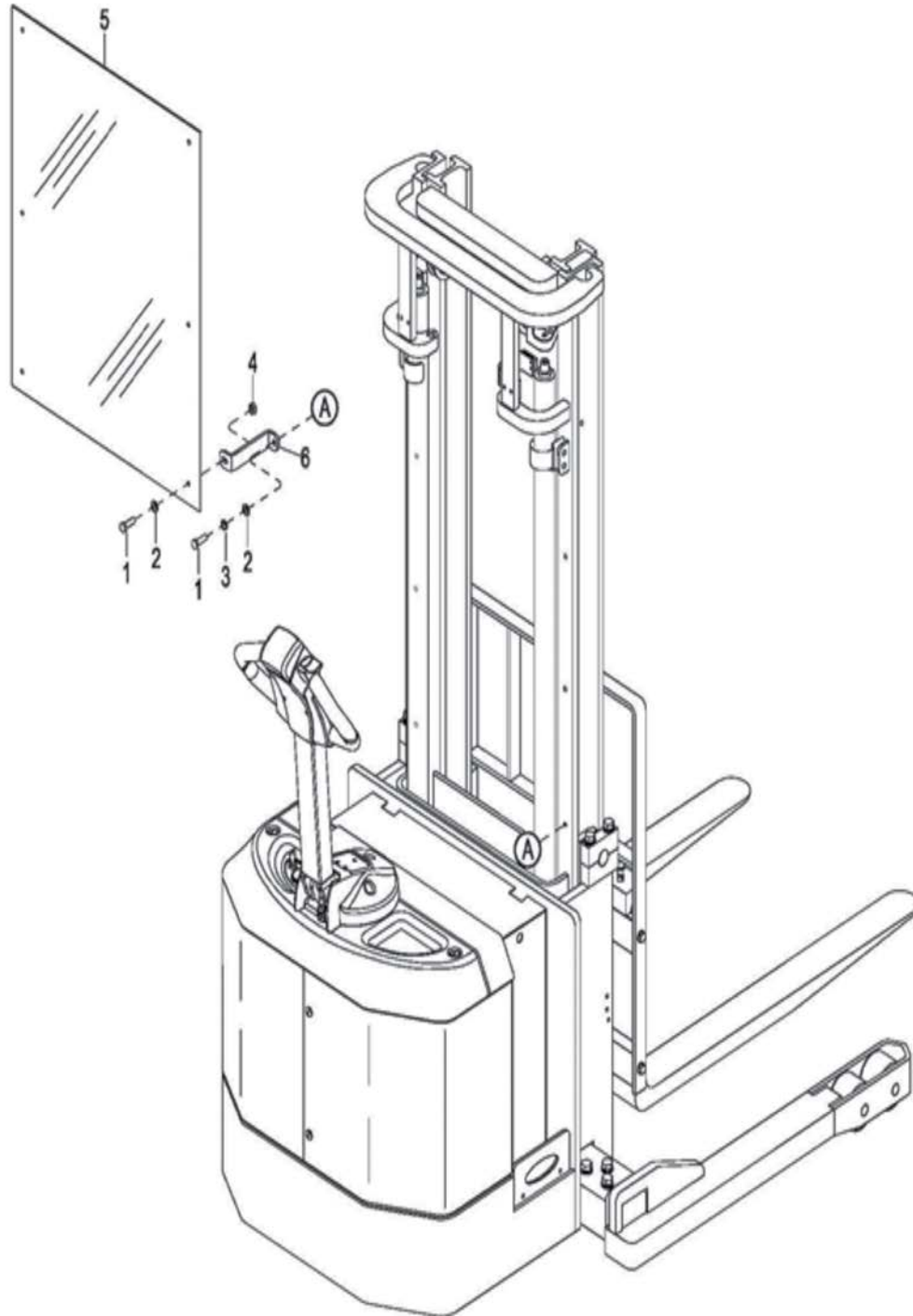

**WINDSHIELD (TELESCOPIC)**

INDEX NO.	PART NO.	PART NAME	NO. REQ.	NOTES
1	0000-000871-00	BOLT M8 x 140	6	Used up to serial number S2121139
1a	0000-000242-00	BOLT M8 x 16	12	Used from serial number S2121140
2	0000-000176-00	FLATWASHER Ø8	12	
3	0000-000159-00	LOCKWASHER Ø8	6	
4	0000-000550-00	NUT M8	6	
5	2130-600001-00-01	WINDSHIELD	1	Used for lift height 104" - Used up to serial number S2121139
5a	2130-600001-0A-01	WINDSHIELD	1	Used for lift height 104" - Used from serial number S2121140
5b	2130-600001-00-03	WINDSHIELD	1	Used for lift height 126" - Used up to serial number S2121139
5c	2130-600001-0A-03	WINDSHIELD	1	Used for lift height 126" - Used from serial number S2121140
5d	2130-600001-00-04	WINDSHIELD	1	Used for lift height 142" - Used up to serial number S2121139
5e	2130-600001-0A-04	WINDSHIELD	1	Used for lift height 142" - Used from serial number S2121140
6	2214-650002-60	ROUND TUBE	6	Used up to serial number S2121139
6a	2125-600009-30	PLATE	6	Used from serial number S2121140

FIGURE 12-14 WINDSHIELD (TRIMAST)

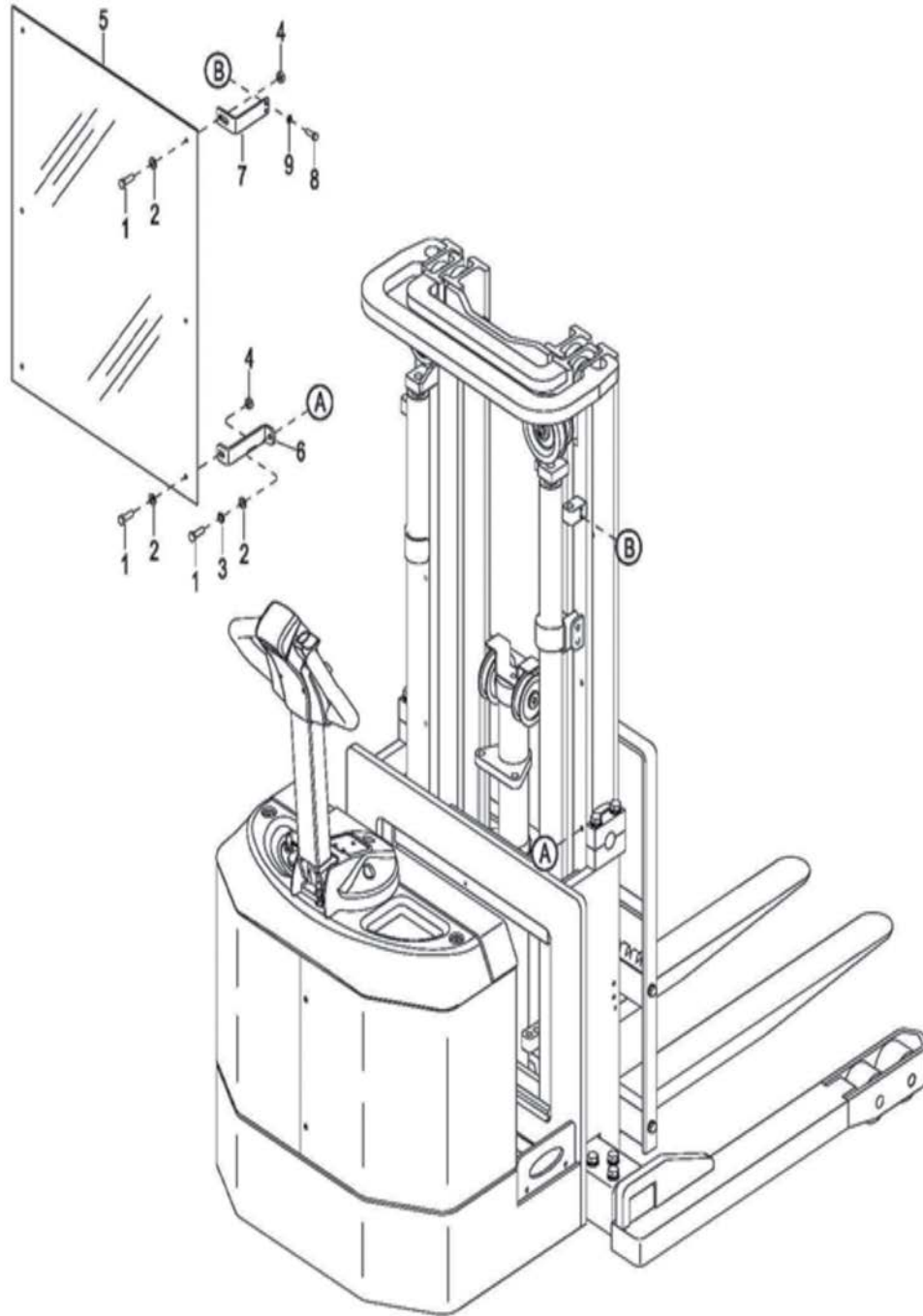

**WINDSHIELD (TRIMAST)**

INDEX NO.	PART NO.	PART NAME	NO. REQ.	NOTES
1	0000-000242-00	BOLT M8 x 16	10	
2	0000-000176-00	FLATWASHER Ø8	4	
3	0000-000159-00	LOCKWASHER Ø8	10	
4	0000-000550-00	NUT M8	6	
5	2130-600001-30-01	WINDSHIELD	1	Used for lift height 157"
5	2130-600001-30-02	WINDSHIELD	1	Used for lift height 177"
6	2125-600009-30	BRACKET	4	
7	2214-650005-60	BRACKET	2	
8	0000-000259-00	BOLT M6 x 16	4	
9	0000-000056-00	LOCKWASHER Ø6	4	
10	2214-150002-00	WASHER	6	Not pictured

FIGURE 12-15 CASTER FOR ADJUSTABLE STRADDLE (BGS-30 ONLY) - UP TO SERIAL NUMBER S2118100

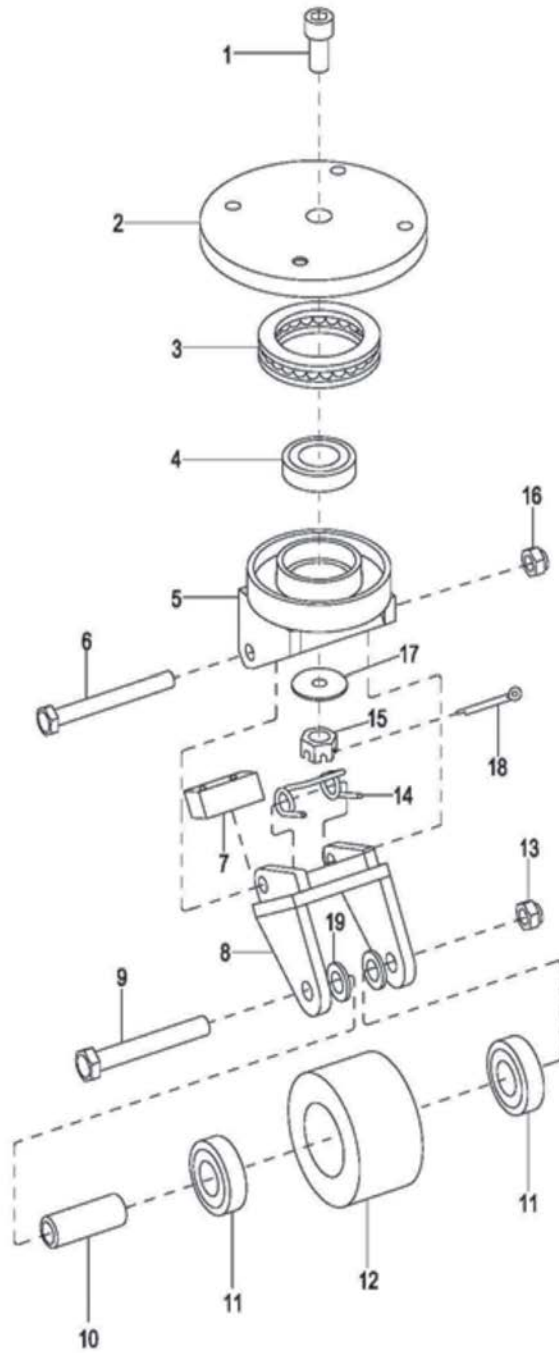



**CASTER FOR ADJUSTABLE STRADDLE - BGS-30 ONLY - UP TO SERIAL NUMBER S211810**

INDEX NO.	PART NO.	PART NAME	NO. REQ.	NOTES
1	1120-140002-00	SCREW M10 x 25	1	
2	1120-140001-00	CASTER SUPPORT	1	
3	0000-000164-00	BEARING	1	
4	0000-000178-00	BEARING	1	
5	1120-141000-00	CASTER SUPPORT	1	
6	0000-000709-00	BOLT M10 x 95	1	
7	1120-140003-00	RUBBER	1	
8	1120-142000-00	WHEEL BRACKET	1	
9	0000-000495-00	BOLT M12 x 85	1	
10	1120-143001-00	SHAFT	1	
11	0000-000020-00	BEARING	2	
12	1120-143003-00	BLANCE WHEEL	1	
13	0000-000057-00	NUT M12	1	
14	1120-140004-00	SPRING	1	
15	0000-000174-00	NUT M10	1	
16	0000-000426-00	NUT M10	1	
17	0000-000175-00	FLATWASHER Ø10	1	
18	0000-000296-00	COTTER PIN Ø2 x 20	1	
19	0000-000435-00	FLATWASHER Ø20	2	

FIGURE 12-16 CASTER FOR ADJUSTABLE STRADDLE (BGS-30 ONLY) - FROM SERIAL NUMBER S2118101

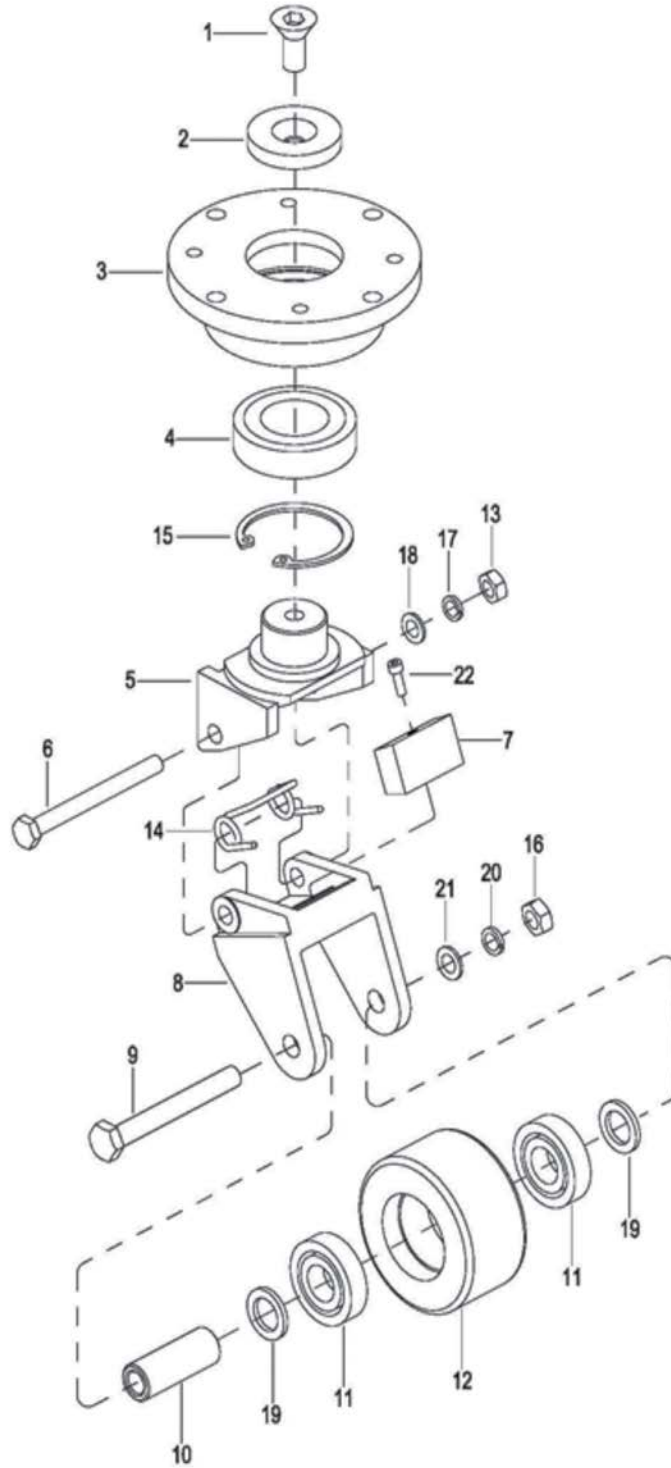

**CASTER FOR ADJUSTABLE STRADDLE - BGS-30 ONLY - FROM SERIAL NUMBER S2118101**

INDEX NO.	PART NO.	PART NAME	NO. REQ.	NOTES
1	0000-000985-00	SCREW M10 x 20	1	
2	1118-140003-00	PLATE	1	
3	1118-140001-00	CASTER SUPPORT	1	
4	0000-000986-00	BEARING	1	
5	1118-140002-00	CASTER SUPPORT	1	
6	0000-000168-00	BOLT M10 x 90	1	
7	1120-140003-00	PU BLOCK	1	
8	1120-142000-00	WHEEL BRACKET	1	
9	0000-000495-00	BOLT M12 x 85	1	
10	1120-143001-00	SHAFT	1	
11	0000-000020-00	BEARING	2	
12	1120-143003-00	PU WHEEL	1	
13	0000-000054-00	NUT M10	1	
14	1120-140004-00	SPRING	1	
15	0000-000987-00	ELASTIC COLLAR □80	1	
16	0000-000165-00	NUT M12	1	
17	0000-000063-00	LOCKWASHER Ø10	1	
18	0000-000007-00	FLATWASHER Ø10	1	
19	0000-000435-00	FLATWASHER Ø20	2	
20	0000-000060-00	LOCKWASHER Ø12	1	
21	0000-000373-00	FLATWASHER Ø12	1	
22	0000-000004-00	SCREW M5 x 12	1	

Figure 12-17 Caster Fixed Straddle (BGS-40 Only)

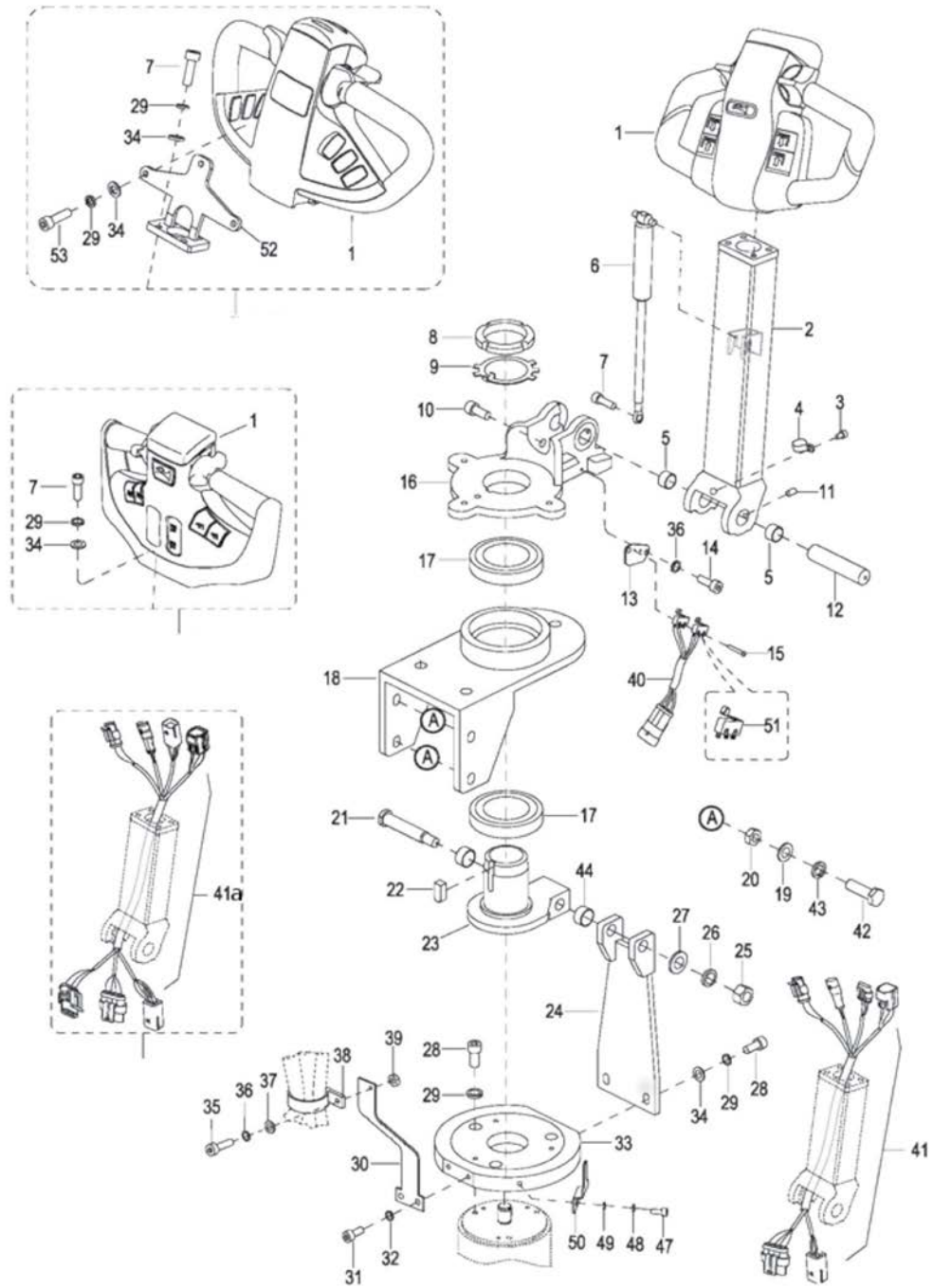

**FIXED STRADDLE (BGS-40 ONLY)**

INDEX NO.	PART NO.	PART NAME	NO. REQ.	NOTES
--	2140-140000-0A	CASTER ASSEMBLY	1	
1	0000-000093-00	NUT M27 x 1.5	1	
2	0000-000094-00	WASHER Ø27	1	
3	1220-140001-00	SNAP RING	1	
4	0000-000420-00	BEARING	1	
5	2140-140002-0A	BEARING BLOCK	1	
6	0000-000421-00	BEARING	1	
7	2140-140004-00	SPRING	2	
8	2140-141000-00	YOKE	1	
9	0000-000242-00	BOLT M8 x 16	2	
10	0000-000159-00	LOCKWASHER Ø8	2	
11	2140-142000-00	HINGE PIN	1	
12	2140-145000-00	SHAFT	1	
13	2140-140003-00	SHAFT	2	
14	2140-143000-00	YOKE	1	
15	2140-144002-00	PU WHEEL	1	
16	0000-000424-00	BEARING	2	

FIGURE 12-18 ELEVATION SYSTEM (TELESCOPIC) - USED UP TO SERIAL NUMBER S2112138

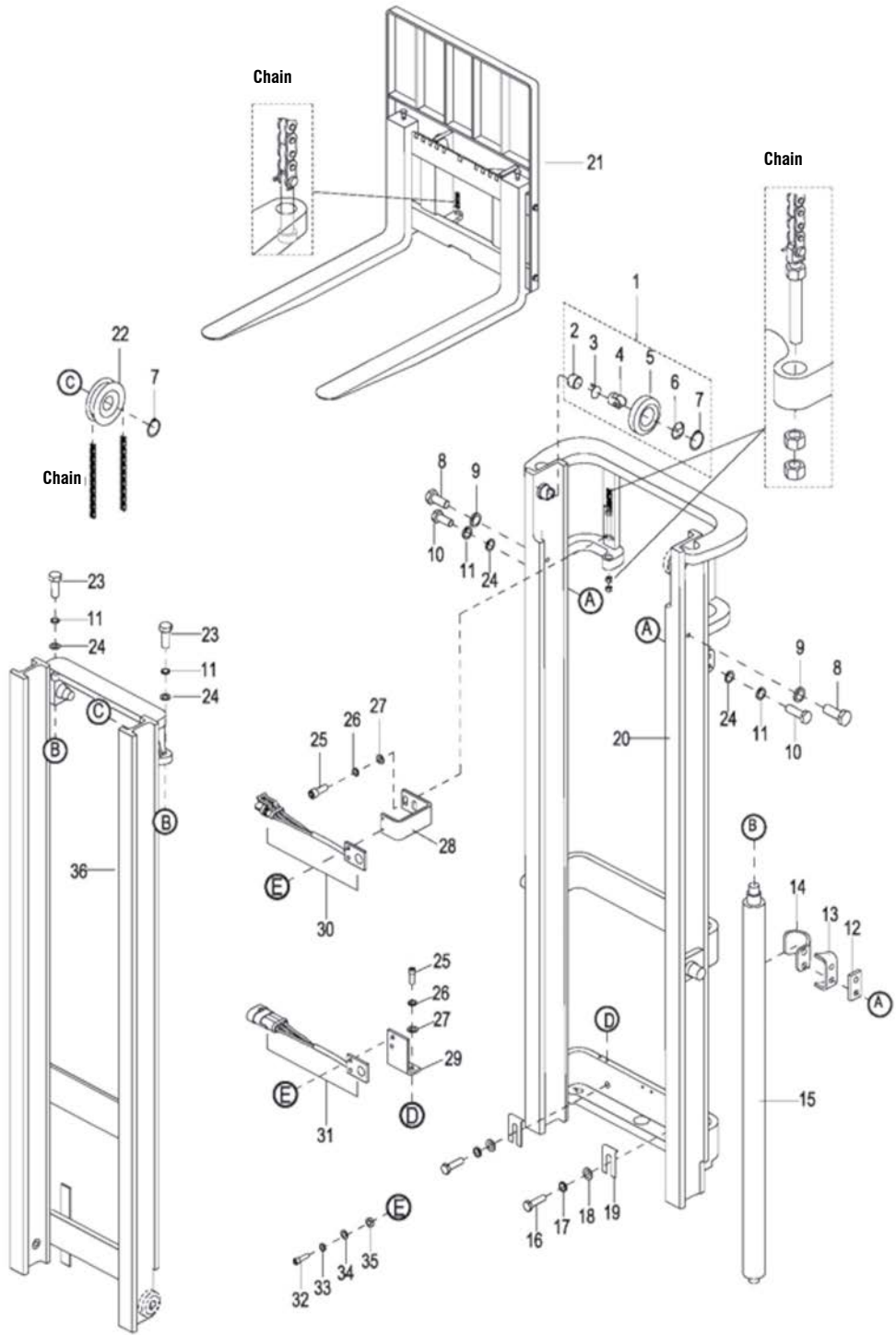

**ELEVATION SYSTEM (TELESCOPIC) - USED UP TO SERIAL NUMBER S2112138**

INDEX NO.	PART NO.	PART NAME	NO. REQ.	NOTES
1	2125-612000-00	ROLLER ASSEMBLY	4	
2	2125-612004-00	SCREW	4	
3	2125-612007-00	SNAP RING	4	
4	2125-612002-00	SUPPORT ROLLER	4	
5	2125-612001-00	MAIN ROLLER ASSEMBLY	4	
6	2125-612005-00	DUST SNAP	4	
7	0000-000183-00	RETAINER RING Ø35	6	
8	0000-000285-00	BOLT M12 x 35	2	
9	0000-000060-00	LOCKWASHER Ø12	2	
10	0000-000283-00	BOLT M10 x 35	4	
11	0000-000063-00	LOCKWASHER Ø10	6	
12	2214-600005-00	WASHER A.R.	A.R.	As Required
13	2214-600004-00	CYLINDER BRACKET	2	
14	2214-600003-00	CYLINDER CLIP	2	
15	2130-410000-00-01	LIFT CYLINDER ASSEMBLY	2	
15a	2130-410000-00-02	LIFT CYLINDER ASSEMBLY	2	Used for lift height 104"
15b	2130-410000-00-03	LIFT CYLINDER ASSEMBLY	2	Used for lift height 126"
16	0000-000622-00	BOLT M16 x 40	2	Used for lift height 142"
17	0000-000191-00	LOCKWASHER Ø16	2	
18	0000-000190-00	FLATWASHER Ø16	2	
19	2214-600006-00	WASHER A.R.	A.R.	As Required
20	2130-610000-00-01	OUTER MAST	1	Used for lift height 104"
20a	2130-610000-00-02	OUTER MAST	1	Used for lift height 126"
20b	2130-610000-00-03	OUTER MAST	1	Used for lift height 142"
20c	2130-610000-10-01	OUTER MAST	1	Used for lift height 104" - When truck has side shift
20d	2130-610000-10-02	OUTER MAST	1	Used for lift height 126" - When truck has side shift
20e	2130-610000-10-03	OUTER MAST	1	Used for lift height 142" - When truck has side shift
21	SEE FORK CARRIAGE	SEE FORK CARRIAGE ASSEMBLY	1	See Telescopic Fork Carriage Section
22	2214-600001-00	CHAIN ROLLER	2	
23	0000-000244-00	BOLT M10 x 30	2	
24	0000-000071-00	FLATWASHER Ø10	6	
25	0000-000109-00	SCREW M8 x 16	4	
26	0000-000159-00	LOCKWASHER Ø8	4	
27	0000-000176-00	FLATWASHER Ø8	4	

FIGURE 12-18 ELEVATION SYSTEM (TELESCOPIC) - USED UP TO SERIAL NUMBER S2112138 (continued)

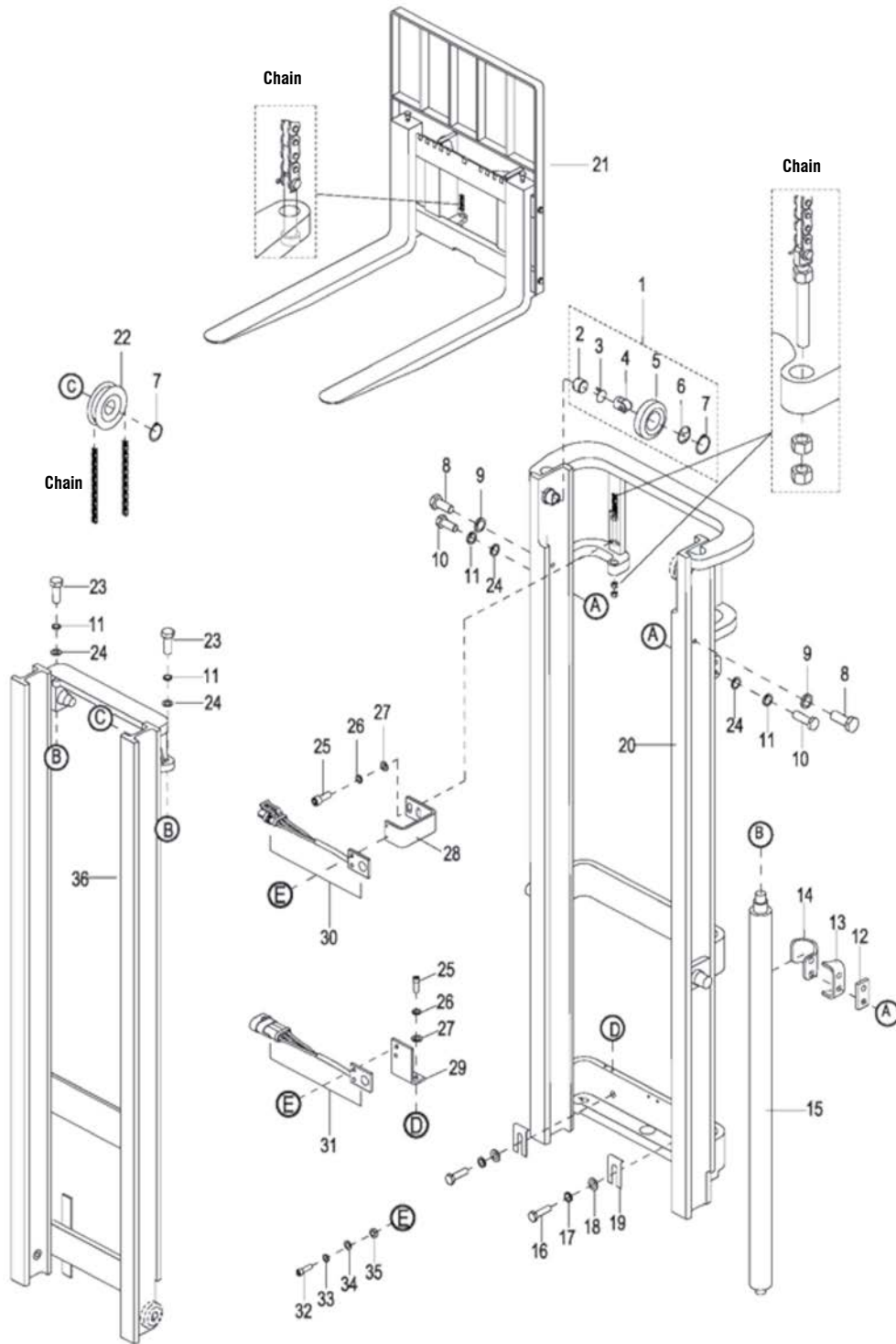



**ELEVATION SYSTEM (TELESCOPIC) - USED UP TO SERIAL NUMBER S2112138 (continued)**

INDEX NO.	PART NO.	PART NAME	NO. REQ.	NOTES
28	2130-500002-00	SENSOR BRACKET	1	
29	2214-500001-00	SENSOR BRACKET	1	
30	2130-520009-00-01	LIFT PROXIMITY SWITCHES WIRING	1	Used for lift height 104"
30a	2130-520009-00-02	LIFT PROXIMITY SWITCHES WIRING	1	Used for lift height 126"
30b	2130-520009-00-03	LIFT PROXIMITY SWITCHES WIRING	1	Used for lift height 142"
31	2130-520003-00	PROXIMITY SWITCHES WIRING	1	
32	0000-000378-00	SCREW M4 x 16	4	
33	0000-000122-00	LOCKWASHER Ø4	4	
34	0000-000702-00	FLATWASHER Ø4	4	
35	0000-000139-00	NUT M4	4	
36	2130-620000-00-01	INNER MAST	1	Used for lift height 104"
36a	2130-620000-00-02	INNER MAST	1	Used for lift height 126"
36b	2130-620000-00-03	INNER MAST	1	Used for lift height 142"
36c	2130-620000-10-01	INNER MAST	1	Used for lift height 104" - When truck has side shift
36d	2130-620000-10-01	INNER MAST	1	Used for lift height 126" - When truck has side shift
36e	2130-620000-10-01	INNER MAST	1	Used for lift height 142" - When truck has side shift

FIGURE 12-19 ELEVATION SYSTEM (TELESCOPIC) - USED FROM SERIAL NUMBER S2112139

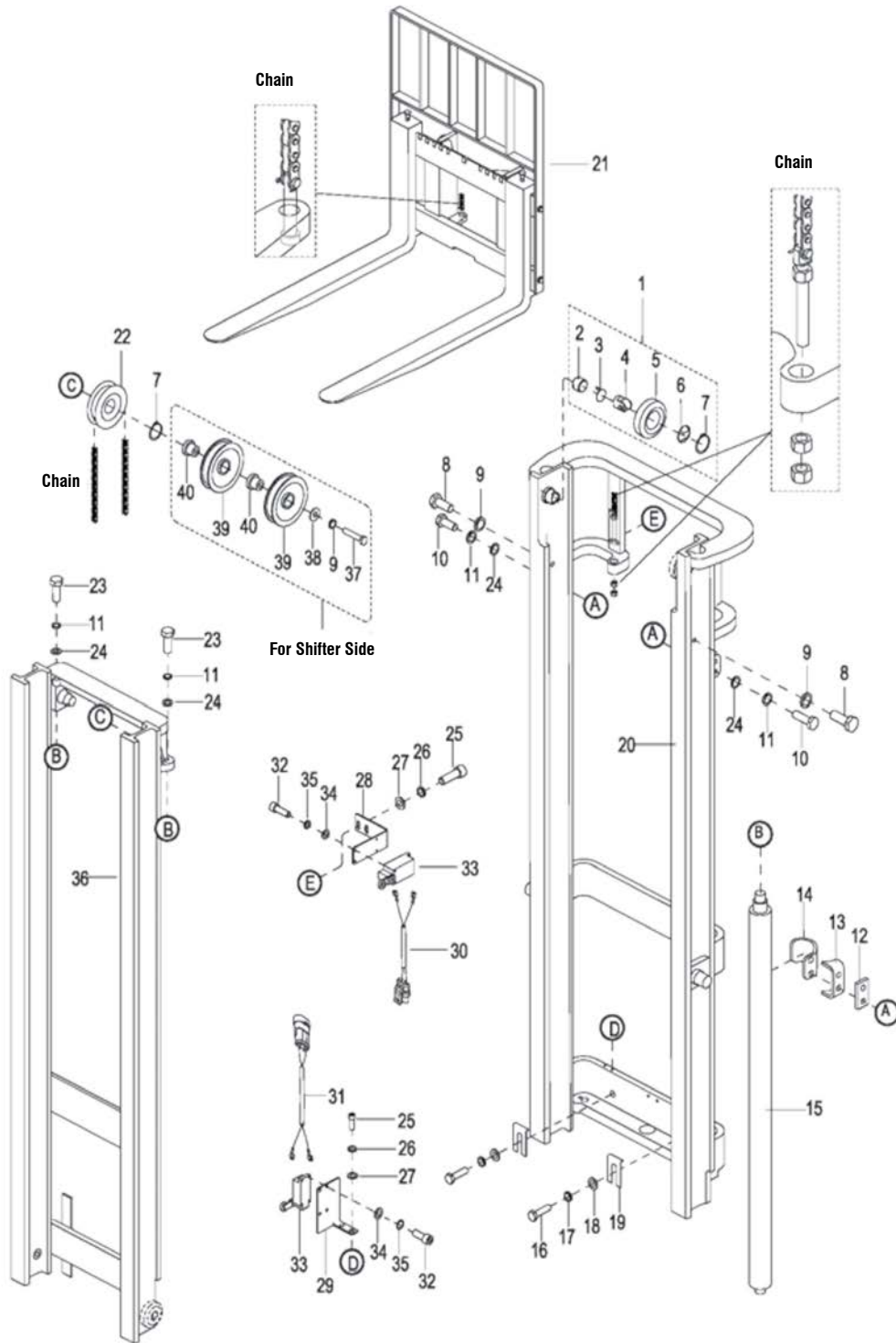

**ELEVATION SYSTEM (TELESCOPIC) - USED FROM SERIAL NUMBER S2112139**

INDEX NO.	PART NO.	PART NAME	NO. REQ.	NOTES
1	2125-612000-00	ROLLER ASSEMBLY	4	
2	2125-612004-00	SCREW	4	
3	2125-612007-00	SNAP RING	4	
4	2125-612002-00	SUPPORT ROLLER	4	
5	2125-612001-00	MAIN ROLLER ASSEMBLY	4	
6	2125-612005-00	DUST SNAP	4	
7	0000-000183-00	RETAINER RING Ø35	6	
8	0000-000285-00	BOLT M12 x 35	2	
9	0000-000060-00	LOCKWASHER Ø12	3	
10	0000-000283-00	BOLT M10 x 35	4	
11	0000-000063-00	LOCKWASHER Ø10	6	
12	2214-600005-00	WASHER	A.R.	As Required
13	2214-600004-00	CYLINDER BRACKET	2	
14	2214-600003-00	CYLINDER CLIP	2	
15	2130-410000-00-01	LIFT CYLINDER ASSEMBLY	2	Used for lift height 104"
15a	2130-410000-00-02	LIFT CYLINDER ASSEMBLY	2	Used for lift height 126"
15b	2130-410000-00-03	LIFT CYLINDER ASSEMBLY	2	Used for lift height 142"
16	0000-000622-00	BOLT M16 x 40	2	
17	0000-000191-00	LOCKWASHER Ø16	2	
18	0000-000190-00	FLATWASHER Ø16	2	
19	2214-600006-00	WASHER	A.R.	As Required
20	2130-610000-00-01	OUTER MAST	1	Used for lift height 104"
20a	2130-610000-00-02	OUTER MAST	1	Used for lift height 126"
20b	2130-610000-00-03	OUTER MAST	1	Used for lift height 142"
20c	2130-610000-10-01	OUTER MAST	1	Used for lift height 104" - When truck has side shift
20d	2130-610000-10-02	OUTER MAST	1	Used for lift height 126" - When truck has side shift
20e	2130-610000-10-03	OUTER MAST	1	Used for lift height 142" - When truck has side shift
21	SEE FORK CARRIAGE	FORK CARRIAGE ASSEMBLY	1	See Telescopic Fork Carriage Section
21a	SEE FORK CARRIAGE	FORK CARRIAGE ASSEMBLY	1	See Telescopic Fork Carriage Section (side shift)
22	2214-600001-00	CHAIN ROLLER	2	
23	0000-000244-00	BOLT M10 x 30	2	
24	0000-000071-00	FLATWASHER Ø10	6	
25	0000-000109-00	SCREW M8 x 16	4	
26	0000-000159-00	LOCKWASHER Ø8	4	
27	0000-000176-00	FLATWASHER Ø8	4	

FIGURE 12-19 ELEVATION SYSTEM (TELESCOPIC) - USED FROM SERIAL NUMBER S2112139 (continued)

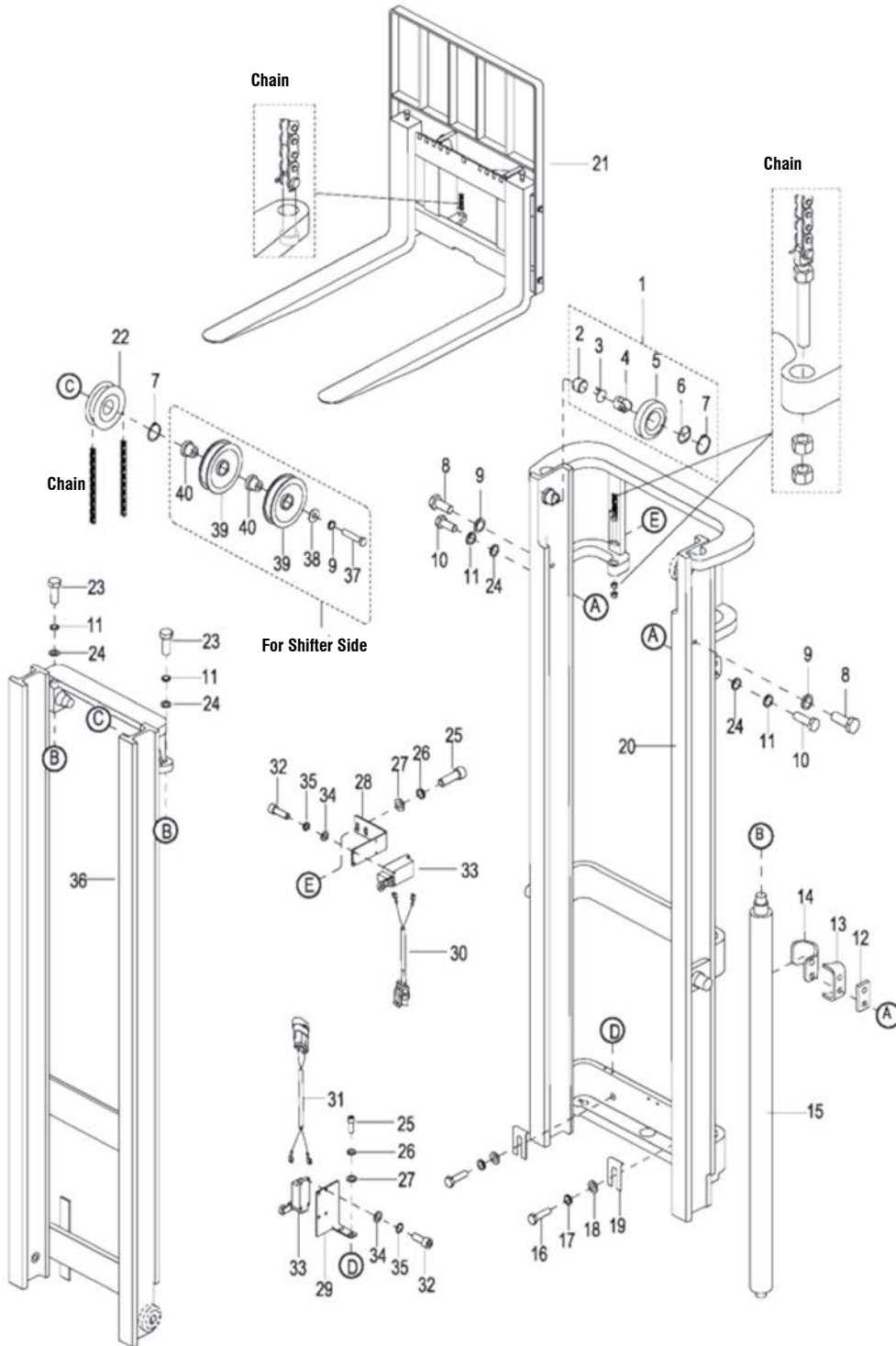

**ELEVATION SYSTEM (TELESCOPIC) - USED FROM SERIAL NUMBER S2112139 (continued)**

INDEX NO.	PART NO.	PART NAME	NO. REQ.	NOTES
28	2130-500002-0A	SENSOR BRACKET	1	
29	2130-500001-0A	SENSOR BRACKET	1	
30	2130-520009-27	PROXIMITY SWITCH WIRING	1	
30a	2130-520009-29	PROXIMITY SWITCH WIRING	1	
30b	2130-520009-31	PROXIMITY SWITCH WIRING	1	
31	2130-520003-0A	PROXIMITY SWITCH WIRING	1	
32	0000-000004-00	SCREW M5 x 12	8	
33	2125-500003-00	PROXIMITY SWITCH	2	
34	0000-000390-00	FLATWASHER Ø5	8	
35	0000-000206-00	LOCKWASHER Ø5	8	
36	2130-620000-00	INNER MAST	1	Used for lift height 104"
36a	2130-620000-00-02	INNER MAST	1	Used for lift height 126"
36b	2130-620000-00-03	INNER MAST	1	Used for lift height 142"
36c	2130-620000-10-01	INNER MAST	1	Used for lift height 104" - When truck has side shift
36d	2130-620000-10-01	INNER MAST	1	Used for lift height 126" - When truck has side shift
36e	2130-620000-10-01	INNER MAST	1	Used for lift height 142" - When truck has side shift
37	0000-000632-00	BOLT M12 x 80	1	Used when side shift
38	0000-000438-00	FLATWASHER Ø12	1	Used when side shift
39	2125-600002-30	HOSE REEL	2	Used when side shift
40	2125-600003-00	BUSHING	2	Used when side shift

FIGURE 12-20 ELEVATION SYSTEM (TRIMAST) - USED UP TO SERIAL NUMBER S2112138

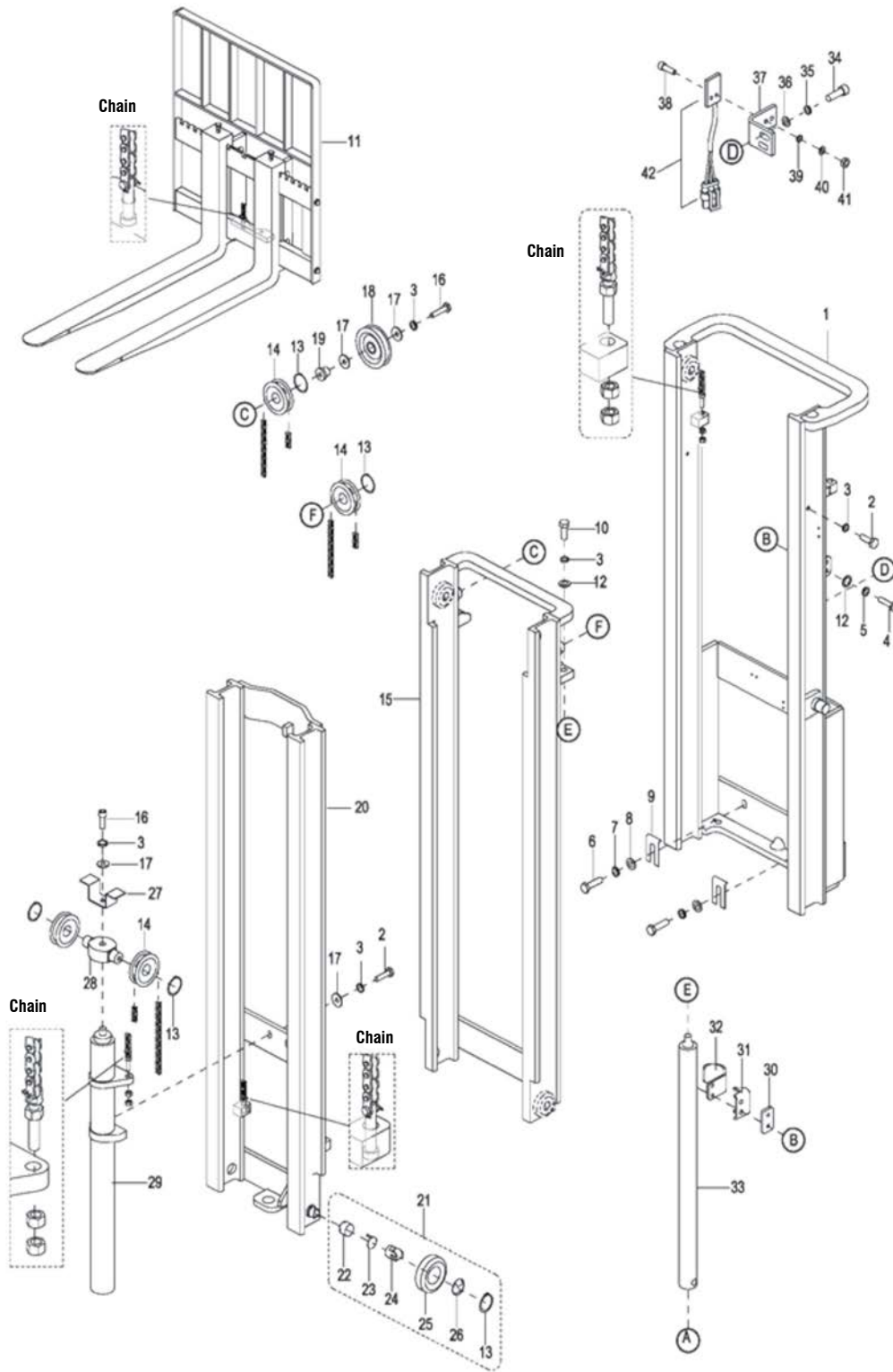

**ELEVATION SYSTEM (TRIMAST) - USED UP TO SERIAL NUMBER S2112138**

INDEX NO.	PART NO.	PART NAME	NO. REQ.	NOTES
1	2130-610000-30-01	OUTER MAST	1	Used for lift height 157"
1a	2130-610000-30-02	OUTER MAST	1	Used for lift height 177"
2	0000-000285-00	BOLT M12 x 30	2	
3	0000-000060-00	LOCKWASHER Ø12	4	
4	0000-000283-00	BOLT M10 x 35	4	
5	0000-000063-00	LOCKWASHER Ø10	6	
6	0000-000622-00	BOLT M16 x 40	2	
7	0000-000191-00	LOCKWASHER Ø16	2	
8	0000-000190-00	FLATWASHER Ø16	2	
9	2214-600006-00	WASHER	A.R.	As Required
10	0000-000244-00	BOLT M10 x 30	2	
11	SEE FORK CARRIAGE	FORK CARRIAGE ASSEMBLY	1	See TRIMAST Fork Carriage Section
12	0000-000071-00	FLATWASHER Ø10	6	
13	0000-000183-00	RETAINER RING Ø35	12	
14	2214-600001-00	CHAIN ROLLER	4	
15	2125-620000-30-01	MIDDLE MAST	1	Used for lift height 157"
15a	2125-620000-30-01	MIDDLE MAST	1	Used for lift height 177"
16	0000-000613-00	BOLT M12 x 50	1	
17	0000-000222-00	FLATWASHER Ø12	2	
18	2125-600002-30	HOSE REEL	1	
19	2125-600003-00	BUSHING	1	
20	2125-630000-30-01	INNER MAST	1	Used for lift height 157"
20a	2125-630000-30-02	INNER MAST	1	Used for lift height 177"
21	2125-612000-00	ROLLER ASSEMBLY	8	
22	2125-612004-00	SCREW	8	
23	2125-612007-00	SNAP RING	8	
24	2125-612002-00	SUPPORT ROLLER	8	
25	2125-612001-00	MAIN ROLLER ASSEMBLY	8	
26	2125-612005-00	DUST SNAP	8	
27	2125-600007-30	BRACKET	1	
28	2125-600001-30	ROLLER BRACKET	1	
29	2130-420000-30-01	FREE LIFT CYLINDER ASSEMBLY	1	Used for lift height 157"
29a	2130-420000-30-02	FREE LIFT CYLINDER ASSEMBLY	1	Used for lift height 177"
30	2214-600005-00	WASHER	A.R.	As Required
31	2125-600006-30	CYLINDER BRACKET	2	
32	2125-600005-30	CLIP	2	
33	2130-410000-30-01	LIFT CYLINDER ASSEMBLY	2	Used for lift height 157"
33a	2130-410000-30-02	LIFT CYLINDER ASSEMBLY	2	Used for lift height 177"

FIGURE 12-20 ELEVATION SYSTEM (TRIMAST) - USED UP TO SERIAL NUMBER S2112138 (continued)

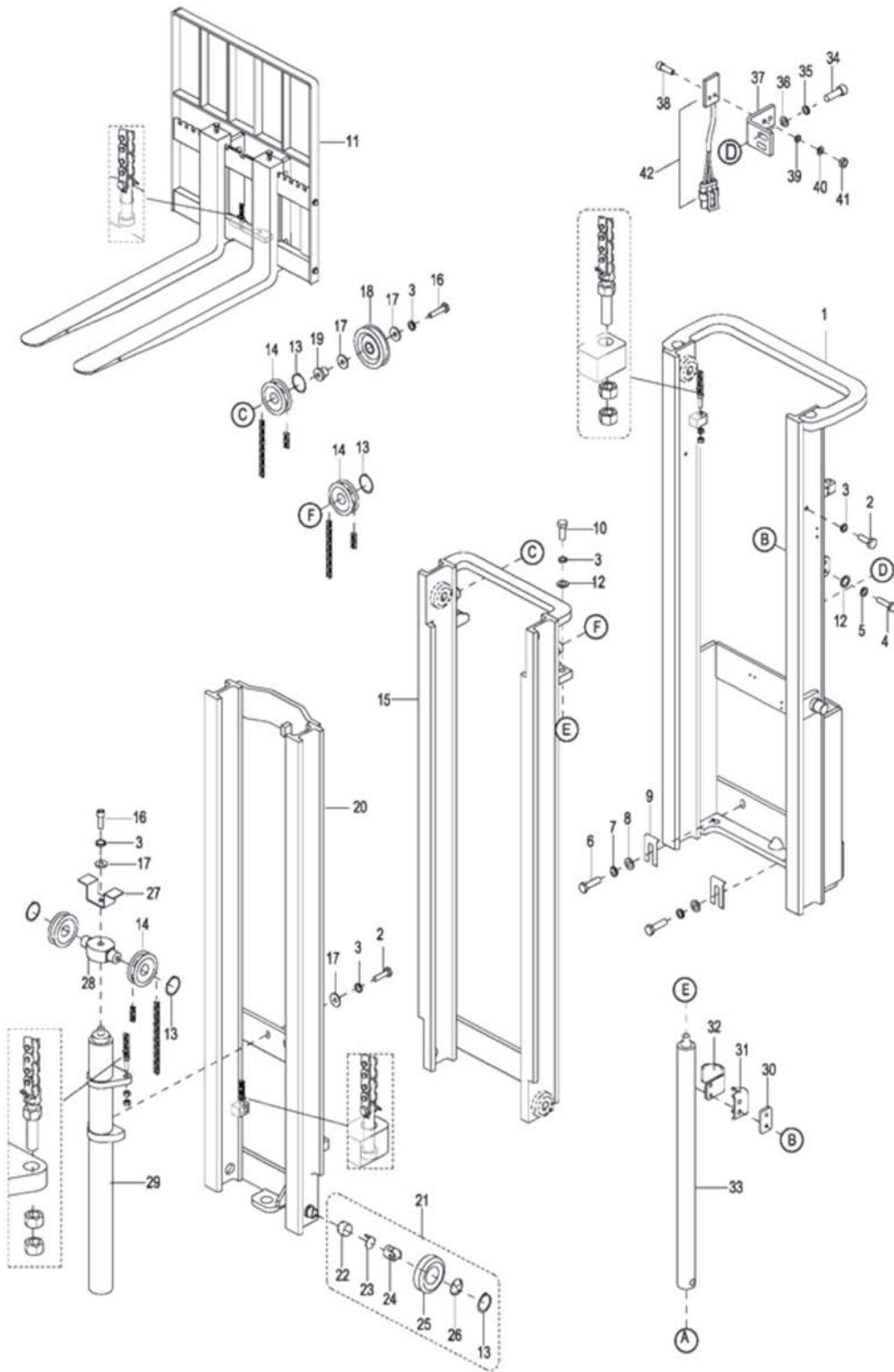



**ELEVATION SYSTEM (TRIMAST) - USED UP TO SERIAL NUMBER S2112138 (continued)**

INDEX NO.	PART NO.	PART NAME	NO. REQ.	NOTES
34	0000-000109-00	SCREW M8 x 16	2	
35	0000-000159-00	LOCKWASHER Ø8	2	
36	0000-000176-00	FLATWASHER Ø8	2	
37	2125-500002-30	SENSOR BRACKET	1	
38	0000-000378-00	SCREW M4 x 16	2	
39	0000-000122-00	LOCKWASHER Ø4	2	
40	0000-000702-00	FLATWASHER Ø4	2	
41	0000-000139-00	NUT M4	2	
42	2130-520009-30-01	LIFT PROXIMITY SWITCHES WIRING	1	Used for lift height 157"
42	2130-520009-30-02	LIFT PROXIMITY SWITCHES WIRING	1	Used for lift height 177"

FIGURE 12-21 ELEVATION SYSTEM (TRIMAST) - USED FROM SERIAL NUMBER S2112139

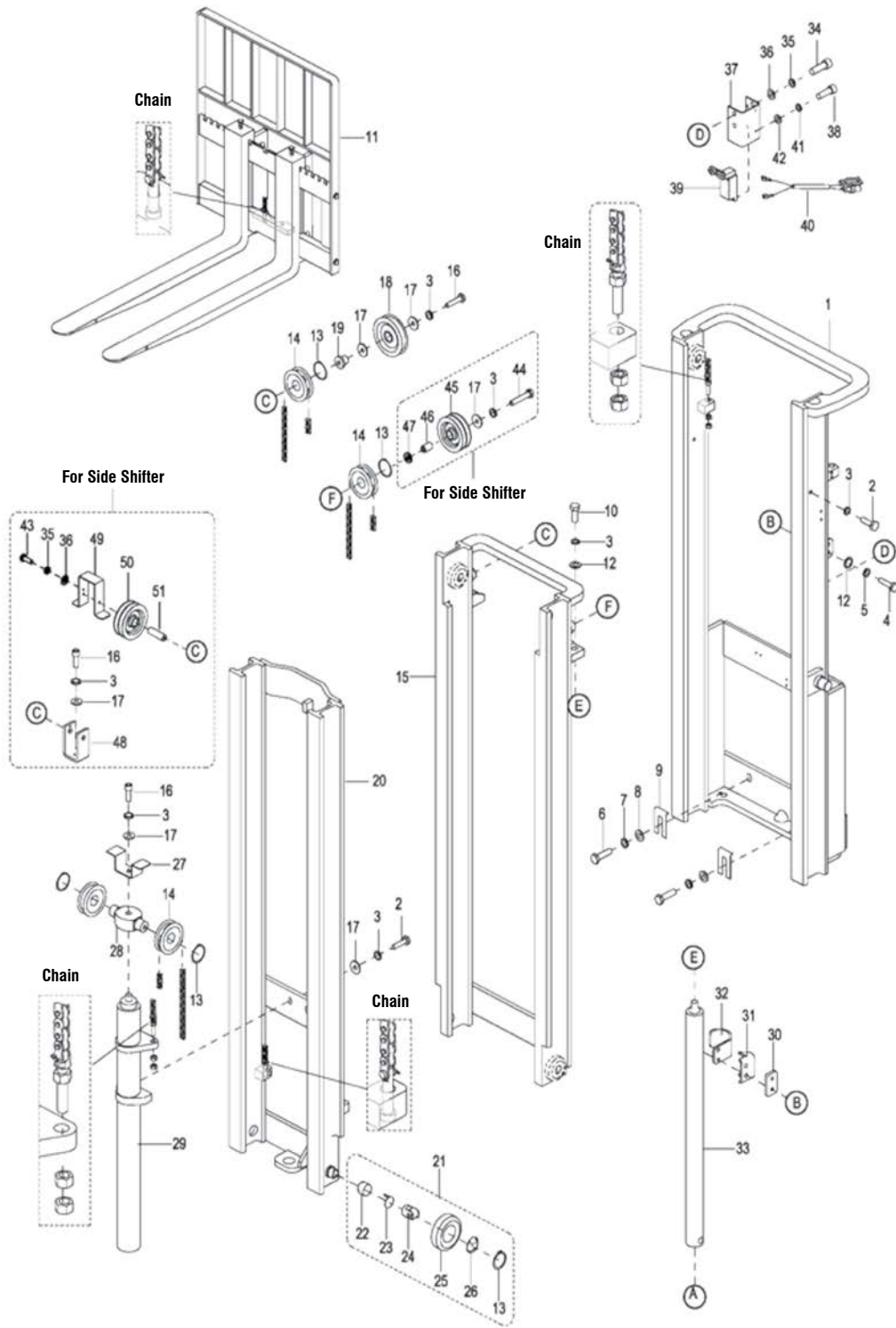

**ELEVATION SYSTEM (TRIMAST) - USED FROM SERIAL NUMBER S2112139**

INDEX NO.	PART NO.	PART NAME	NO. REQ.	NOTES
1	2130-610000-30-01	OUTER MAST	1	Used for lift height 157"
1a	2130-610000-30-02	OUTER MAST	1	Used for lift height 177"
2	0000-000285-00	BOLT M12 x 30	2	
3	0000-000060-00	LOCKWASHER Ø12	5	
4	0000-000283-00	BOLT M10 x 35	4	
5	0000-000063-00	LOCKWASHER Ø10	6	
6	0000-000622-00	BOLT M16 x 40	2	
7	0000-000191-00	LOCKWASHER Ø16	2	
8	0000-000190-00	FLATWASHER Ø16	2	
9	2214-600006-00	WASHER Req.	Req.	
10	0000-000244-00	BOLT M10 x 30	2	
11	SEE FORK CARRIAGE	FORK CARRIAGE ASSEMBLY	1	See TRIMAST Fork Carriage Section
11a	SEE FORK CARRIAGE	FORK CARRIAGE ASSEMBLY	1	See TRIMAST Fork Carriage Section
12	0000-000071-00	FLATWASHER Ø10	6	
13	0000-000183-00	RETAINER RING Ø35	12	
14	2214-600001-00	CHAIN ROLLER	4	
15	2125-620000-30-01	MIDDLE MAST	1	Used for lift height 157"
15a	2125-620000-30-01	MIDDLE MAST	1	Used for lift height 177"
16	0000-000613-00	BOLT M12 x 50	2	
17	0000-000222-00	FLATWASHER Ø12	2	
18	2125-600002-30	OIL PIPE ROLLER	1	
19	2125-600003-00	BUSHING	1	
20	2125-630000-30-01	INNER MAST	1	Used for lift height 157"
20a	2125-630000-30-02	INNER MAST	1	Used for lift height 177"
21	2125-612000-00	ROLLER ASSEMBLY	8	
22	2125-612004-00	SCREW	8	
23	2125-612007-00	SNAP RING	8	
24	2125-612002-00	SUPPORT ROLLER	8	
25	2125-612001-00	MAIN ROLLER ASSEMBLY	8	
26	2125-612005-00	DUST SNAP	8	
27	2125-600007-30	BRACKET	1	
28	2125-600001-30	ROLLER BRACKET	1	
29	2130-420000-30-01	FREE LIFT CYLINDER ASSEMBLY	1	Used for lift height 157"
29a	2130-420000-30-02	FREE LIFT CYLINDER ASSEMBLY	1	Used for lift height 177"
30	2214-600005-00	WASHER Req.	Req.	
31	2125-600006-30	CYLINDER BRACKET	2	
32	2125-600005-30	CLIP	2	

FIGURE 12-21 ELEVATION SYSTEM (TRIMAST) - USED FROM SERIAL NUMBER S2112139 (continued)

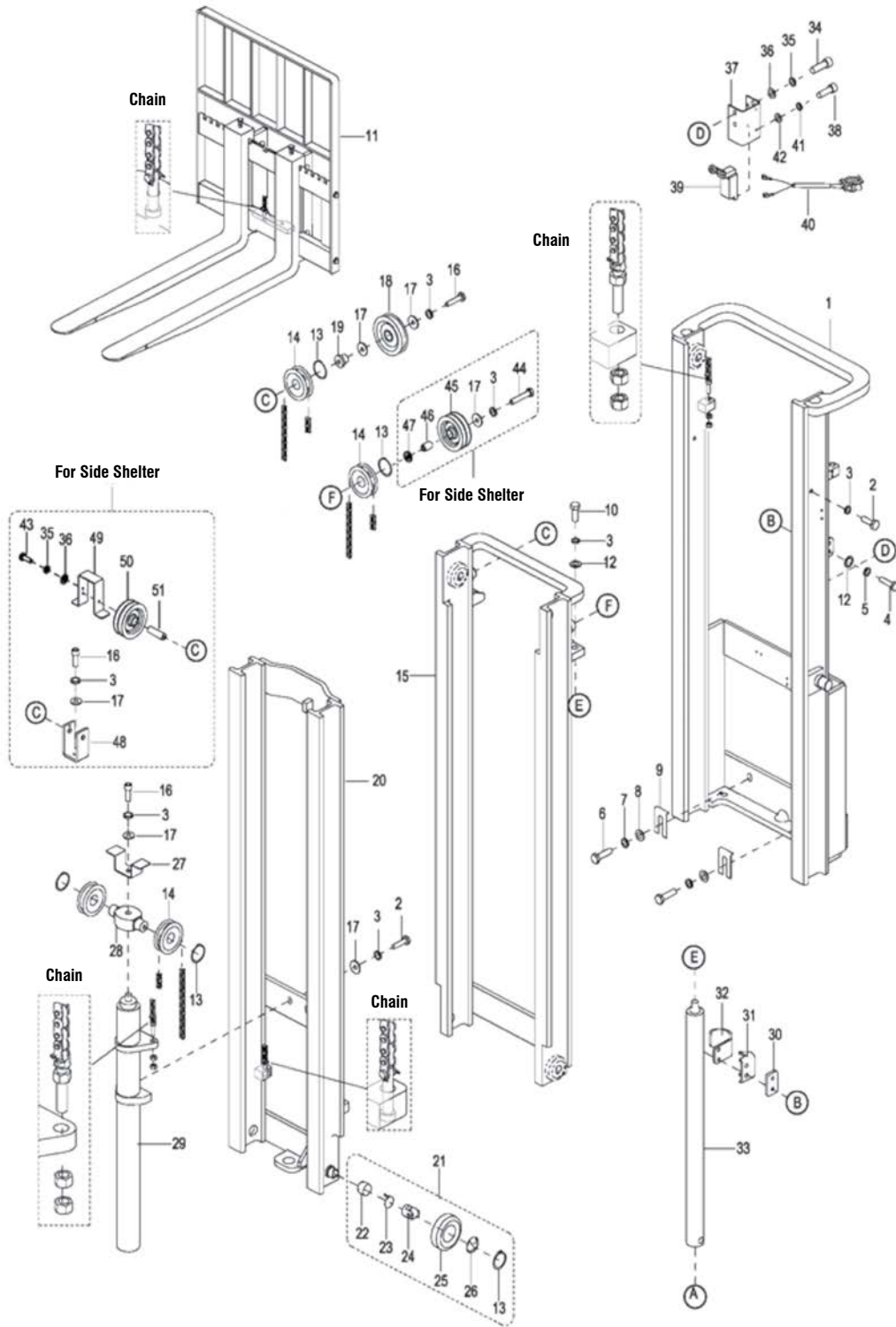

**ELEVATION SYSTEM (TRIMAST) - USED FROM SERIAL NUMBER S2112139 (continued)**

INDEX NO.	PART NO.	PART NAME	NO. REQ.	NOTES	
33	2130-410000-30-01	LIFT CYLINDER ASSEMBLY	2	2 Used for lift height 157" Used for lift height 177"	
33a	2130-410000-30-02	LIFT CYLINDER ASSEMBLY	2	Used for lift height 157" Used for lift height 177"	
34	0000-000109-00	SCREW M8 x 16	2		
35	0000-000159-00	LOCKWASHER Ø8	3		
36	0000-000176-00	FLATWASHER Ø8	3		
37	2125-500002-3A	SENSOR BRACKET	1		
38	0000-000004-00	SCREW M5 x 12	4		
39	2125-500002-00	PROXIMITY SWITCH	1		Used when Side Shift option on truck
39a	2125-500003-00	PROXIMITY SWITCH	1		Used when Side Shift option on truck
40	2125-520009-24	PROXIMITY SWITCH WIRING	1		
40a	2125-520009-26	PROXIMITY SWITCH WIRING	1		
41	0000-000206-00	LOCKWASHER Ø5	4		
42	0000-000390-00	FLATWASHER Ø5	4		
43	0000-000242-00	BLOT M8 x 16	3	Used when Side Shift option on truck	
44	0000-000919-00	BOLT M12 x 65	1	Used when Side Shift option on truck	
45	K25S100007-Y	DOUBLE TUBE ROUND	1	Used when Side Shift option on truck	
46	3215-800002-30	TUBE AXLE	1	Used when Side Shift option on truck	
47	3215-800001-30	PLATE	1	Used when Side Shift option on truck	
48	3215-800004-30	FIXED PLATE	1	Used when Side Shift option on truck	
49	3215-800005-30	BRACKET	1	Used when Side Shift option on truck	
50	3215-800006-30	MIDDLE TUBE ROUND	1	Used when Side Shift option on truck	
51	3215-800003-30	TUBE AXLE	1	Used when Side Shift option on truck	

**FIGURE 12-22 FORK CARRIAGE - TELESCOPIC**

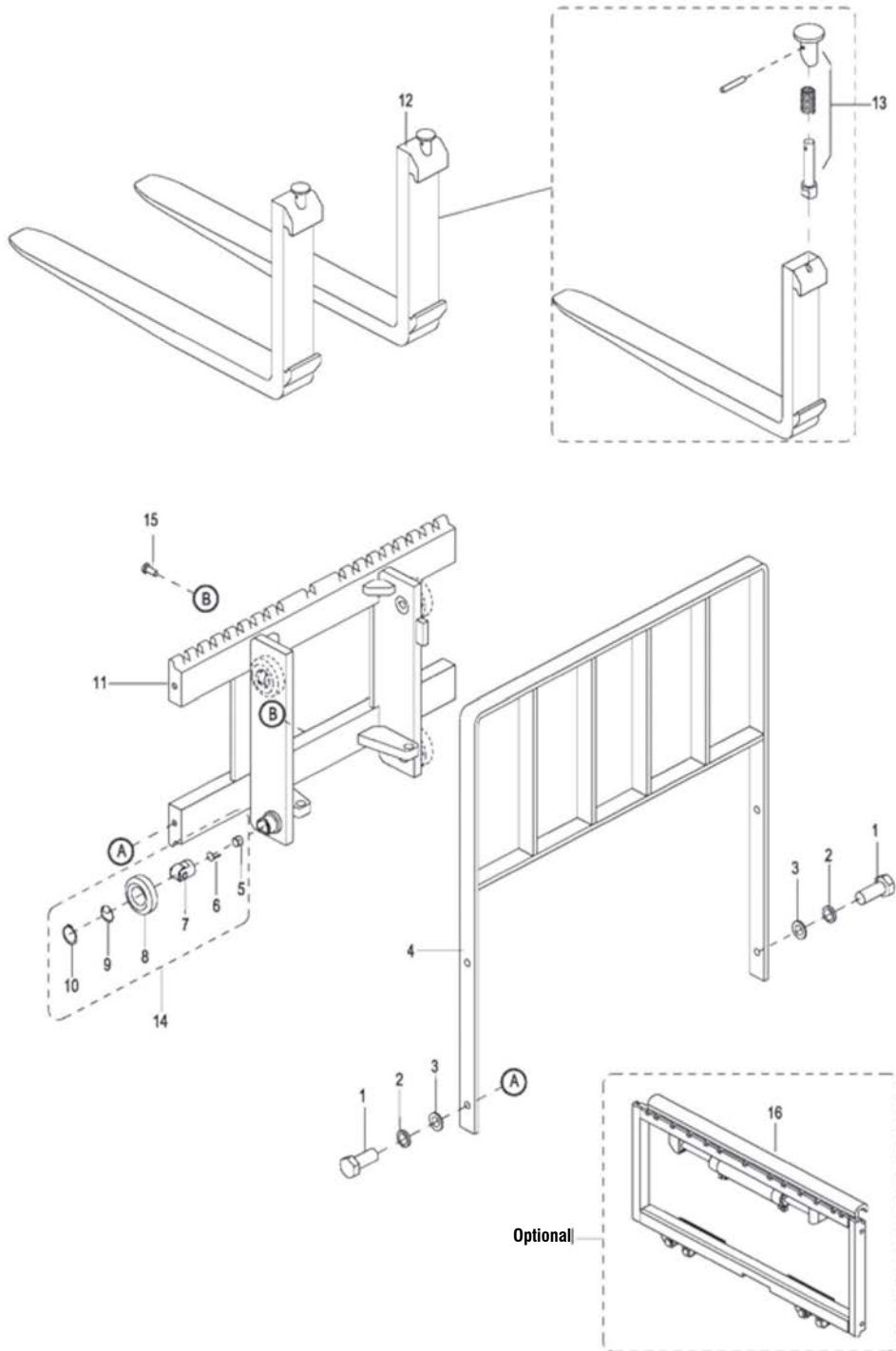

**FORK CARRIAGE - TELESCOPIC**

INDEX NO.	PART NO.	PART NAME	NO. REQ.	NOTES
1	0000-000221-00	BOLT M12 x 30	4	
2	0000-000060-00	LOCKWASHER Ø12	4	
3	0000-000373-00	FLATWASHER Ø12	4	
4	2125-632000-00	LOAD BACKREST	1	36" Load Backrest
4a	2125-632000-10	LOAD BACKREST	1	48" Load Backrest
5	2125-631104-00	SCREW	4	
6	2125-612007-00	SNAP RING	4	
7	2125-612002-00	SUPPORT ROLLER	4	
8	2125-612001-00	MAIN ROLLER ASSEMBLY	4	
9	2125-612005-00	DUST SNAP	4	
10	0000-000183-00	RETAINER RING Ø35	4	
11	2130-631000-00	FORK CARRIAGE	1	
11a	2130-631000-10	FORK CARRIAGE	1	Used when Side Shift Option
12	2125-630001-00	FORK	2	
13	2125-630001-10	PIN ASSEMBLY	2	
14	2125-631100-00	ROLLER ASSEMBLY	1	
15	0000-000030-00	SCREW M10 x 16	1	
16	2130-641000-40	SIDE SHIFT ATTACHMENT	1	Optional

FIGURE 12-23 FORK CARRIAGE - TRIMAST

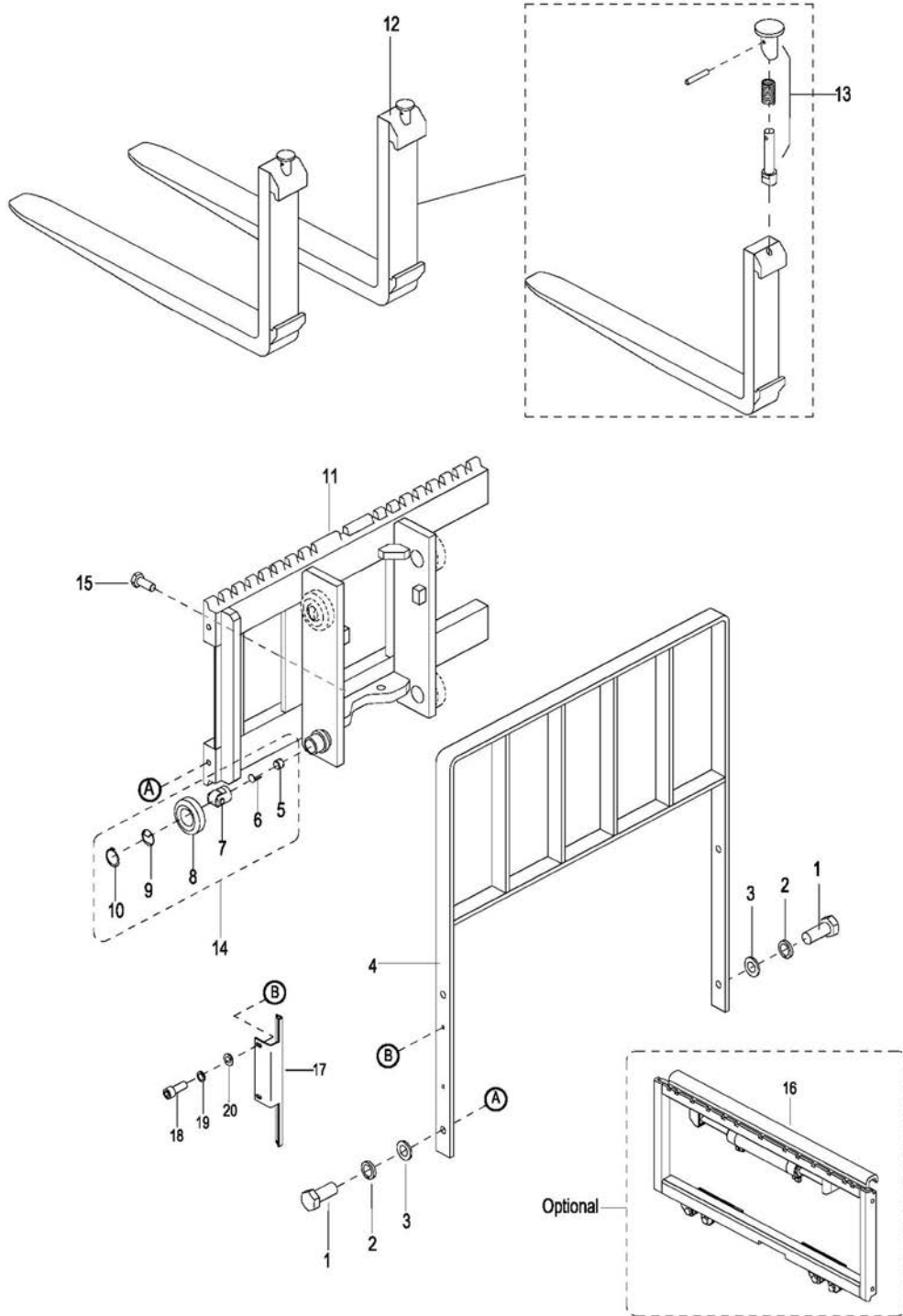



**FORK CARRIAGE - TRIMAST**

INDEX NO.	PART NO.	PART NAME	NO. REQ.	NOTES
1	0000-000221-00	BOLT M12 x 30	4	
2	0000-000060-00	LOCKWASHER Ø12	4	
3	0000-000373-00	FLATWASHER Ø12	4	
4	2125-632000-00	LOAD BACKREST	1	36" Load Backrest - Used up to serial number 324170029
4	2125-632000-0A	LOAD BACKREST	1	36" Load Backrest - Used from serial number 324170030
4a	2125-632000-10	LOAD BACKREST	1	48" Load Backrest - Used up to serial number 324170029
4a	2125-632000-1A	LOAD BACKREST	1	48" Load Backrest - Used from serial number 324170030
5	2125-631104-00	SCREW	4	
6	2125-612007-00	SNAP RING	4	
7	2125-612002-00	SUPPORT ROLLER	4	
8	2125-612001-00	MAIN ROLLER ASSEMBLY	4	
9	2125-612005-00	DUST SNAP	4	
10	0000-000183-00	RETAINER RING Ø35	4	
11	2125-641000-30	FORK CARRIAGE	1	Used up to serial number 324200418
11a	2125-641000-30	FORK CARRIAGE	1	With bracket mount for speed reduction switch - Used from serial number 324200419
12	2125-630001-00	FORK	2	
13	2125-630001-10	PIN ASSEMBLY	2	
14	2125-631100-00	ROLLER ASSEMBLY	4	
15	0000-000030-00	SCREW M10 x 16	1	
16	2130-641000-40	SIDE SHIFT ATTACHMENT	1	Optional
17	2130-642000-30	PLATE	1	Used between serial number 324170030 and 324200418
18	0000-000109-00	SCREW M8 x 16	2	Used between serial number 324170030 and 324200418
19	0000-000159-00	LOCKWASHER Ø8	2	Used between serial number 324170030 and 324200418
20	0000-000176-00	FLATWASHER Ø8	2	Used between serial number 324170030 and 324200418

FIGURE 12-24 SIDE SHIFT ASSEMBLY

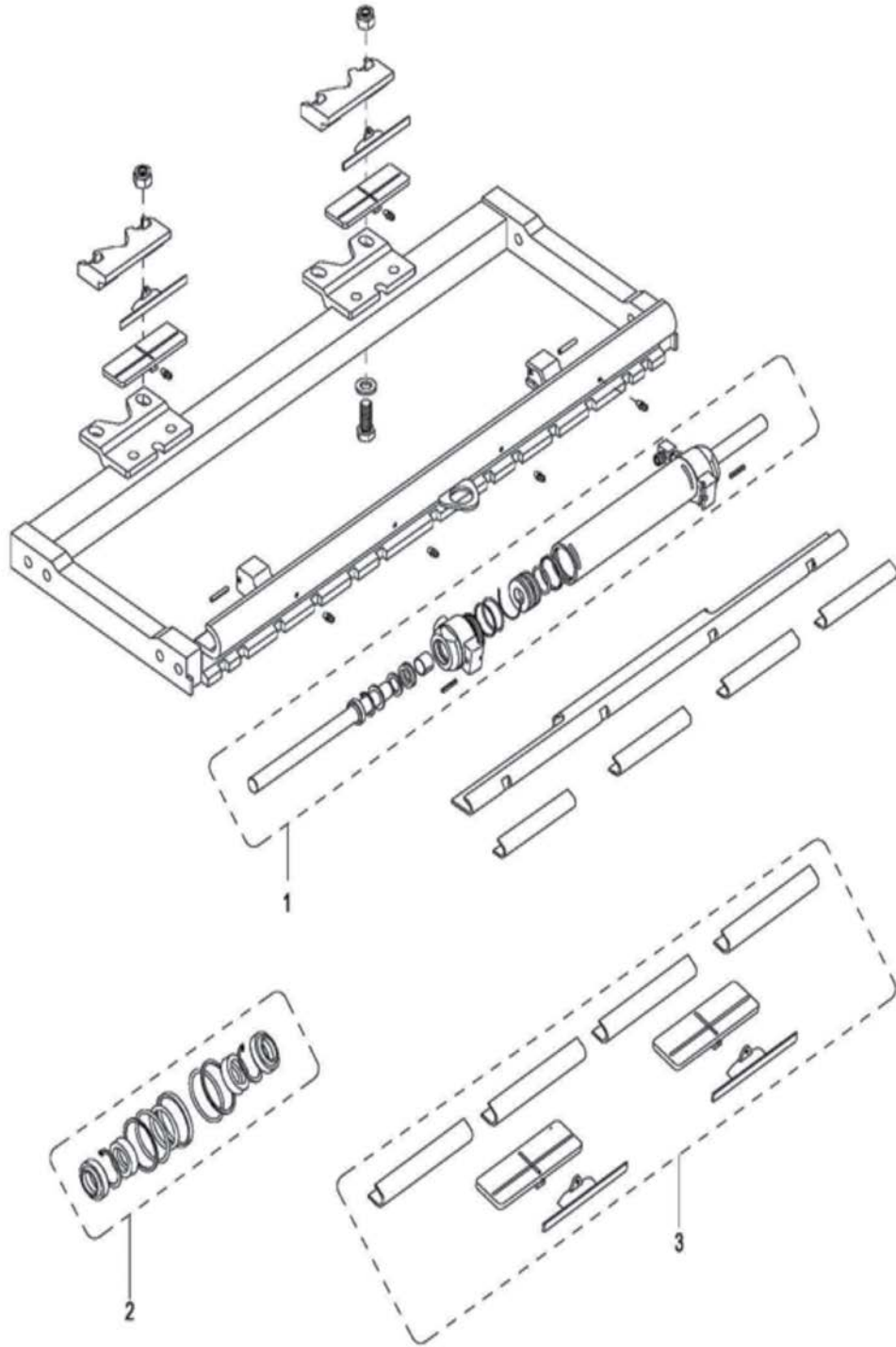

**SIDE SHIFT ASSEMBLY**

INDEX NO.	PART NO.	PART NAME	NO. REQ.	NOTES
1	2130-6410001-40	CYLINDER ASSEMBLY 1	1	
2	2130-ZWCYG-0A	SEAL KIT FOR CYLINDER 1	1	
3	2130-ZWHK-0A	PLASTIC SLIDER PLATE KIT 1	1	

FIGURE 12-25 CHAIN ASSEMBLY

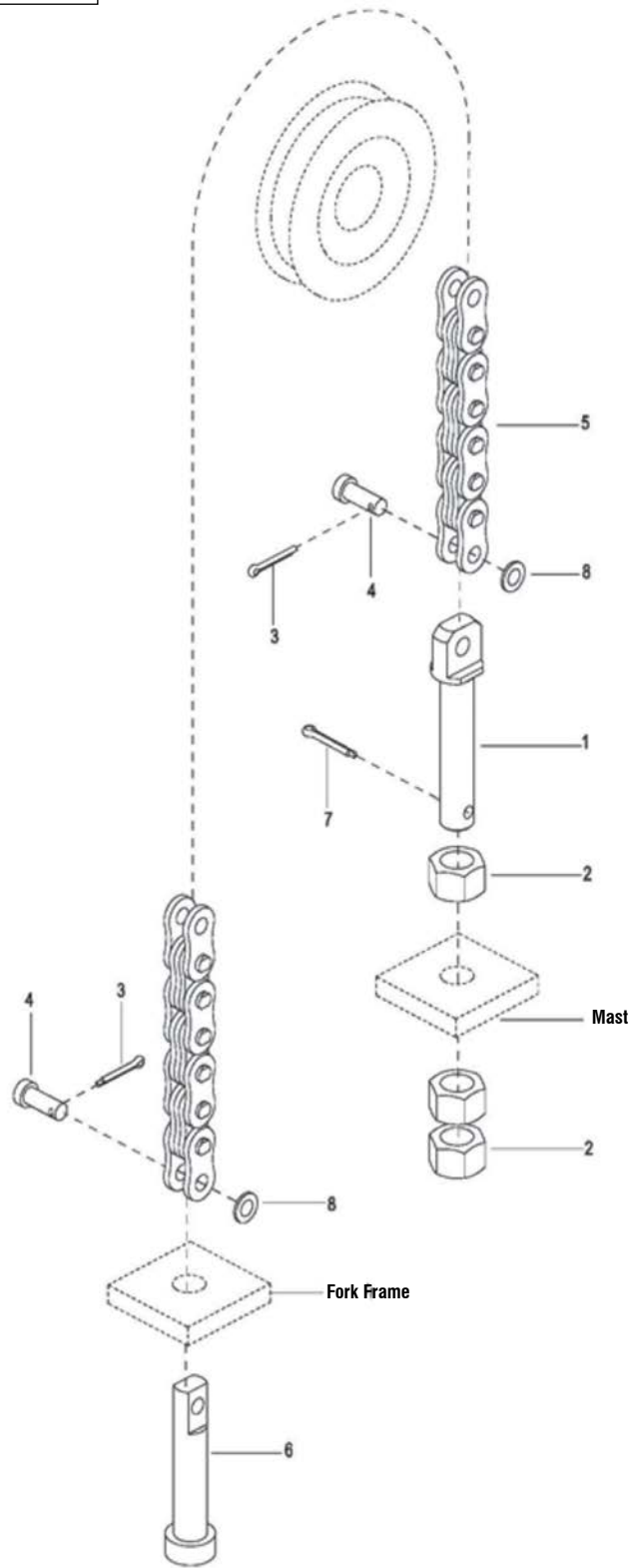

**CHAIN ASSEMBLY**

INDEX NO.	PART NO.	PART NAME	NO. REQ.	NOTES
1	2125-640001-00	BOLT	1	
2	0000-000187-00	NUT M16 x 1.5	3	
3	0000-000188-00	COTTER PIN Ø3.2 x 20	2	
4	2125-640002-00	PIN	2	
5	2125-640000-00-02	CHAIN ASSEMBLY	1	1 Used for lift height 104" - Telescopic
5	2125-640000-00-04	CHAIN ASSEMBLY	1	1 Used for lift height 126" - Telescopic
5	2125-640000-00-06	CHAIN ASSEMBLY	1	1 Used for lift height 142" - Telescopic
5	2125-651000-30-01	CHAIN ASSEMBLY - CHAIN I (FREELIFT)	1	1 Used for lift height 157" - TRIMAST
5	2125-652000-30-01	CHAIN ASSEMBLY - CHAIN II (SECONDARY)	1	1 Used for lift height 157" - TRIMAST
5	2125-651000-30-02	CHAIN ASSEMBLY - CHAIN I (FREELIFT)	1	1 Used for lift height 177" - TRIMAST
5	2125-652000-30-02	CHAIN ASSEMBLY - CHAIN II (SECONDARY)	1	1 Used for lift height 177" - TRIMAST
6	2125-640003-00	CHAIN ANCHOR	1	
7	0000-000686-00 COT	COTTER PIN Ø3.2 x 32	1	
8	0000-000176-00	FLATWASHER Ø8	2	

FIGURE 12-26 HYDRAULIC SYSTEM (NOT USED WHEN SIDE SHIFT OPTION)

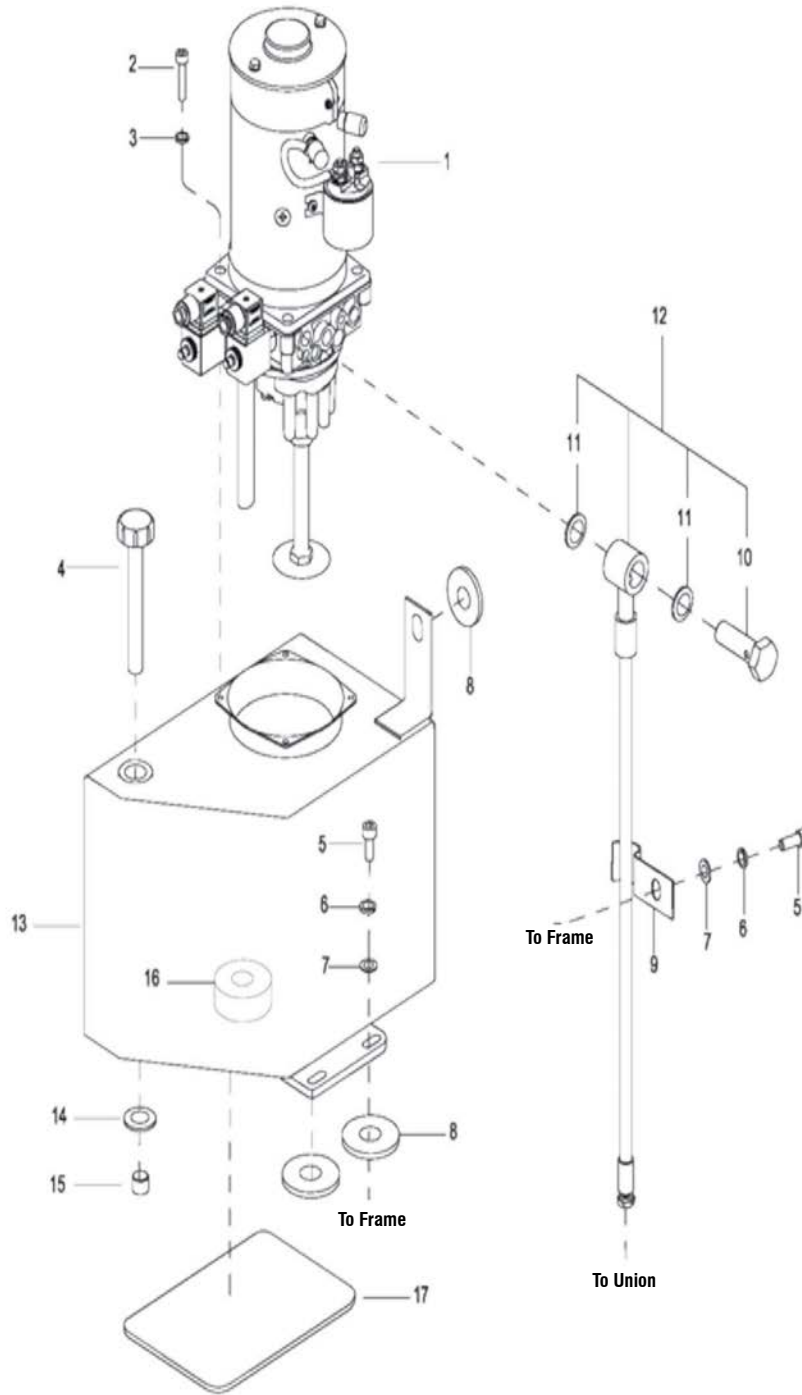

**HYDRAULIC SYSTEM (NOT USED WHEN SIDE SHIFT OPTION)**

INDEX NO.	PART NO.	PART NAME	NO. REQ.	NOTES
1	--	PUMP AND MOTOR ASSEMBLY	1	Used up to serial number S2117012. The hydraulic unit is no longer available. please order 2130- 430000-0a (pos. 1a) together with wire 1220- 520014-00
1a	2130-430000-0A	PUMP AND MOTOR ASSEMBLY	1	Used from serial number S2117013
2	0000-000710-00	SCREW M6 x 45	4	
3	0000-000056-00	LOCKWASHER Ø6	4	
4	2130-423000-00	FILTER	1	
5	0000-000109-00	SCREW M8 x 16	4	
6	0000-000159-00	LOCKWASHER Ø8	4	
7	0000-000176-00	FLATWASHER Ø8	4	
8	2112-410004-00	WASHER	3	
9	2112-400002-00	HOSE CLAMP	1	
10	2402-143500-00	CONNECTOR BOLT G1/4 x 35	1	For BGS-30
11	0000-000044-00	WASHER Ø14	4	
12	2130-460000-00	HOSE	1	For BGS-30
12a	2140-410000-00	HOSE	1	For BGS-40
13	2130-421000-00	TANK	1	
14	0000-000510-00	WASHER Ø20	1	
15	0000-000635-00	PLUG M18 x 1.5	1	
16	2125-420001-00	MAGNET	1	
17	2112-410005-00	RUBBER CUSHION	1	

FIGURE 12-27 HYDRAULIC SYSTEM (USED WHEN SIDE SHIFT OPTION)

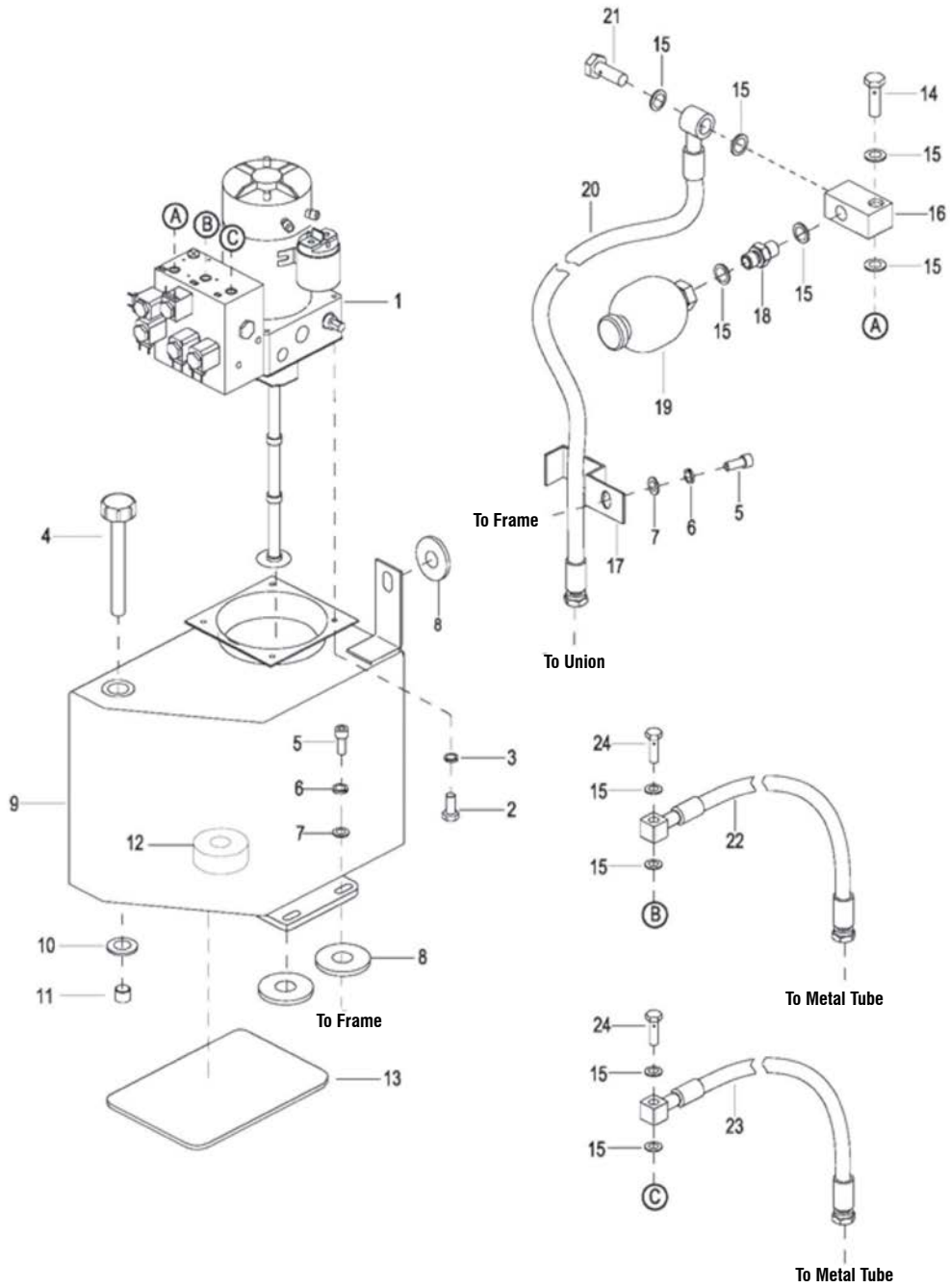



**HYDRAULIC SYSTEM (USED WHEN SIDE SHIFT OPTION)**

INDEX NO.	PART NO.	PART NAME	NO. REQ.	NOTES
1	2130-470000-40	PUMP AND MOTOR ASSEMBLY	1	
2	0000-000620-00	BOLT M 6 x 16	4	
3	0000-000056-00	LOCKWASHER Ø6	4	
4	2130-423000-00	FILTER	1	
5	0000-000109-00	SCREW M8 x 16	5	
6	0000-000159-00	LOCKWASHER Ø8	5	
7	0000-000176-00	FLATWASHER Ø8	5	
8	2112-410004-00	WASHER	3	
9	2130-421000-40	TANK	1	
10	0000-000510-00	WASHER Ø20	1	
11	0000-000635-00	PLUG M18 x 1.5	1	
12	2125-420001-00	MAGNET	1	
13	2112-410005-00	RUBBER CUSHION	1	
14	2402-144000-00	BOLT G1/4 x 40	1	
15	0000-000044-00	WASHER Ø14	10	
16	2214-420001-0B	BLOCK CROSS	1	
17	2130-400001-40	HOSE CLAMP	1	
18	2701-141400-00	CONNECTOR M14X1.5-M14X1.5	1	
19	2214-423000-00	ACCUMULATOR	1	
20	2130-460000-00	HOSE	1	
21	2402-143500-00	BOLT G1/4 x 35	1	
22	2130-410000-10	OIL PIPE I	1	Used on Telescopic Mast BGS-30
22a	2130-410000-40	OIL PIPE I	1	Used on TRIMAST Mast BGS-30
22b	2140-410000-10	OIL PIPE I	1	Used on Telescopic Mast BGS-40
22c	2140-410000-40	OIL PIPE I	1	Used on TRIMAST Mast BGS-40
23	2130-420000-10	OIL PIPE II	1	Used on Telescopic Mast BGS-30
23a	2130-460000-40	OIL PIPE II	1	Used on TRIMAST Mast BGS-30
23b	2140-420000-10	OIL PIPE II	1	Used on Telescopic Mast BGS-40
23c	2140-460000-40	OIL PIPE II	1	Used on TRIMAST Mast BGS-40
24	2402-143700-A0	BOLT G1/4 x 37	2	

FIGURE 12-28 PUMP AND MOTOR ASSEMBLY - NOT WHEN SIDE SHIFT OPTION - (USED UP TO SERIAL NUMBER S2117012)

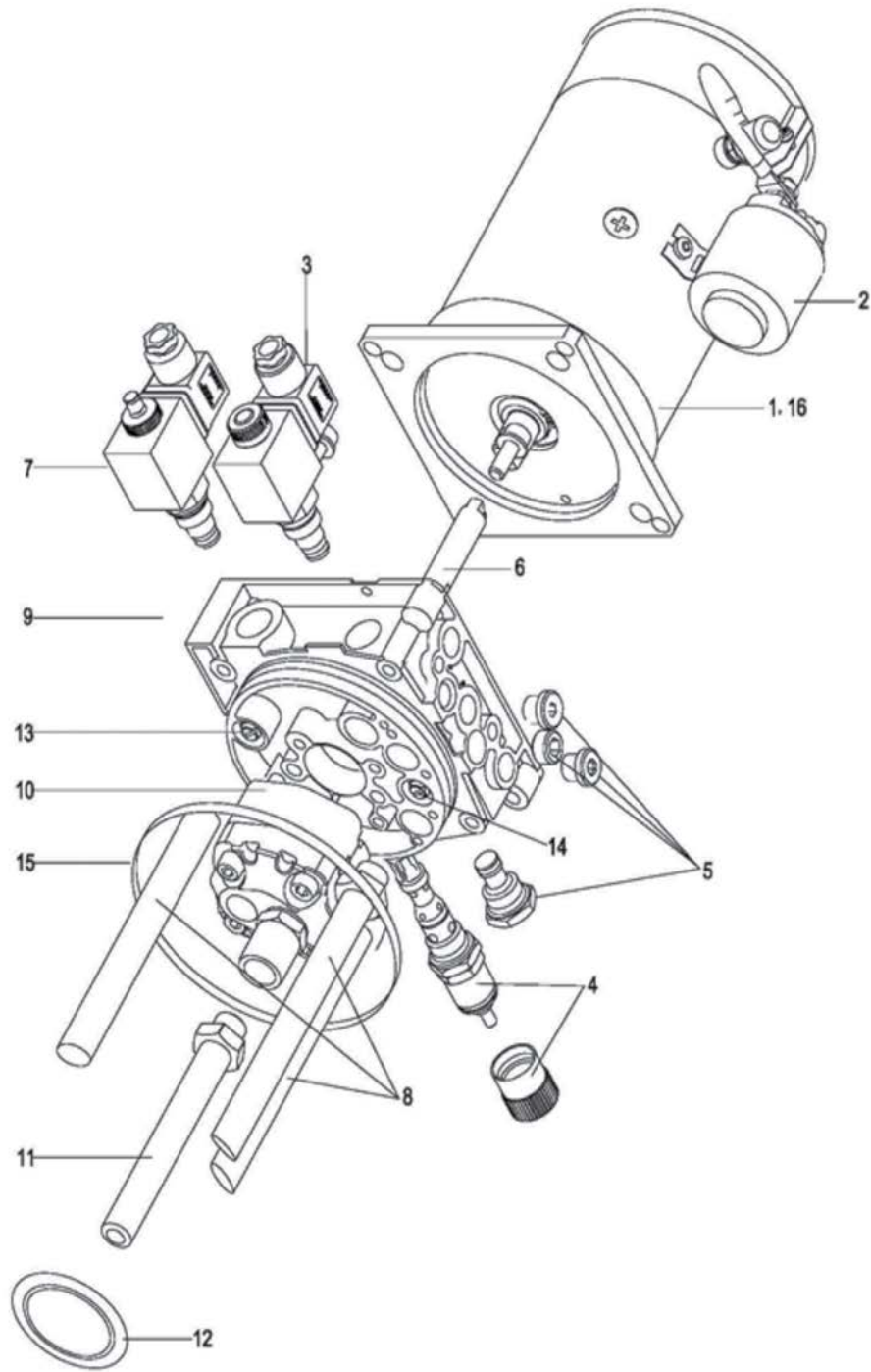

**PUMP AND MOTOR ASSEMBLY - NOT WHEN SIDE SHIFT OPTION (USED UP TO SERIAL NUMBER S2117012)**

INDEX NO.	PART NO.	PART NAME	NO. REQ.	NOTES
--	--	PUMP AND MOTOR ASSEMBLY	1	The hydraulic unit is no longer available. please order 2130-430000-0a together with wire 1220-520014-00
1	2130-430001-00	MOTOR	1	
2	2130-430002-00	CONTACTOR	1	
3	2130-430003-00	SOLENOID VALVE	1	
4	2130-430004-00	RELIEF VALVE	1	
5	2130-430005-00	SCREW	4	
6	2130-430006-00	REACH	1	
7	2130-430007-00	SOLENOID VALVE	1	
8	2130-430008-00	RETURN TUBE	1	
9	2130-430009-00	ADAPTER	1	
10	2130-430010-00	PUMP	1	
11	2130-430011-00	SUCK TUBE	1	
12	2130-430012-00	FILTER , STEEL	1	
13	2130-430013-00	CONTROL VALVE 12L/MIN	1	
14	2130-430014-00	FLOW CONTROL VALVE 6L/MIN	1	
15	2130-430015-00	RING	1	
16	2130-430016-00	BRUSH	1	

FIGURE 12-29 PUMP AND MOTOR ASSEMBLY - NOT WHEN SIDE SHIFT OPTION - (USED FROM SERIAL NUMBER S2117013)

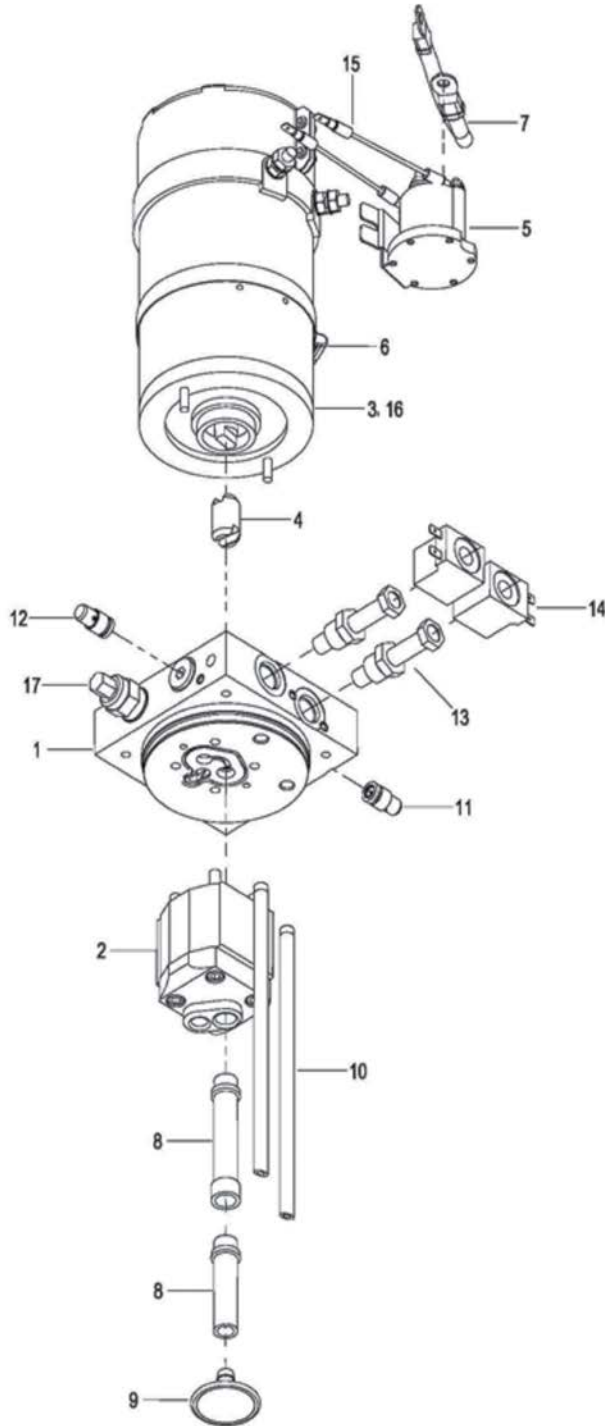

**PUMP AND MOTOR ASSEMBLY - NOT WHEN SIDE SHIFT OPTION (USED FROM SERIAL NUMBER S2117013)**

INDEX NO.	PART NO.	PART NAME	NO. REQ.	NOTES
--	2130-430000-0A	PUMP AND MOTOR ASSEMBLY	1	
1	2130-430001-0A	ADAPTER	1	
2	2130-430002-0A	PUMP	1	
3	2130-430003-0A	MOTOR	1	
4	2130-430004-0A	ADAPTER	1	
5	1120-420017-00	CONTACTOR	1	
6	2130-430006-0A	CLAMP	1	
7	2130-430007-0A	CABLE	1	
8	2130-430008-0A	SUCTION TUBE	2	
9	2130-430009-0A	FILTER , STEEL	1	
10	2130-430010-0A	RETURN TUBE	2	
11	2130-430011-0A	FLOW CONTROL VALVE GPM2.0	1	
12	2130-430012-0A	FLOW CONTROL VALVE GPM3.0	1	
13	1120-420010-00	RELEASE VALVE	2	
14	1120-420011-00	SOLENOID VALVE	2	
15	2130-430015-0A	WIRE	2	
16	2130-430016-0A	BRUSH	1	
17	2130-430017-0A	RELIEF VALVE	1	

FIGURE 12-30 PUMP AND MOTOR ASSEMBLY (USED WHEN SIDE SHIFT OPTION ON TRUCK)

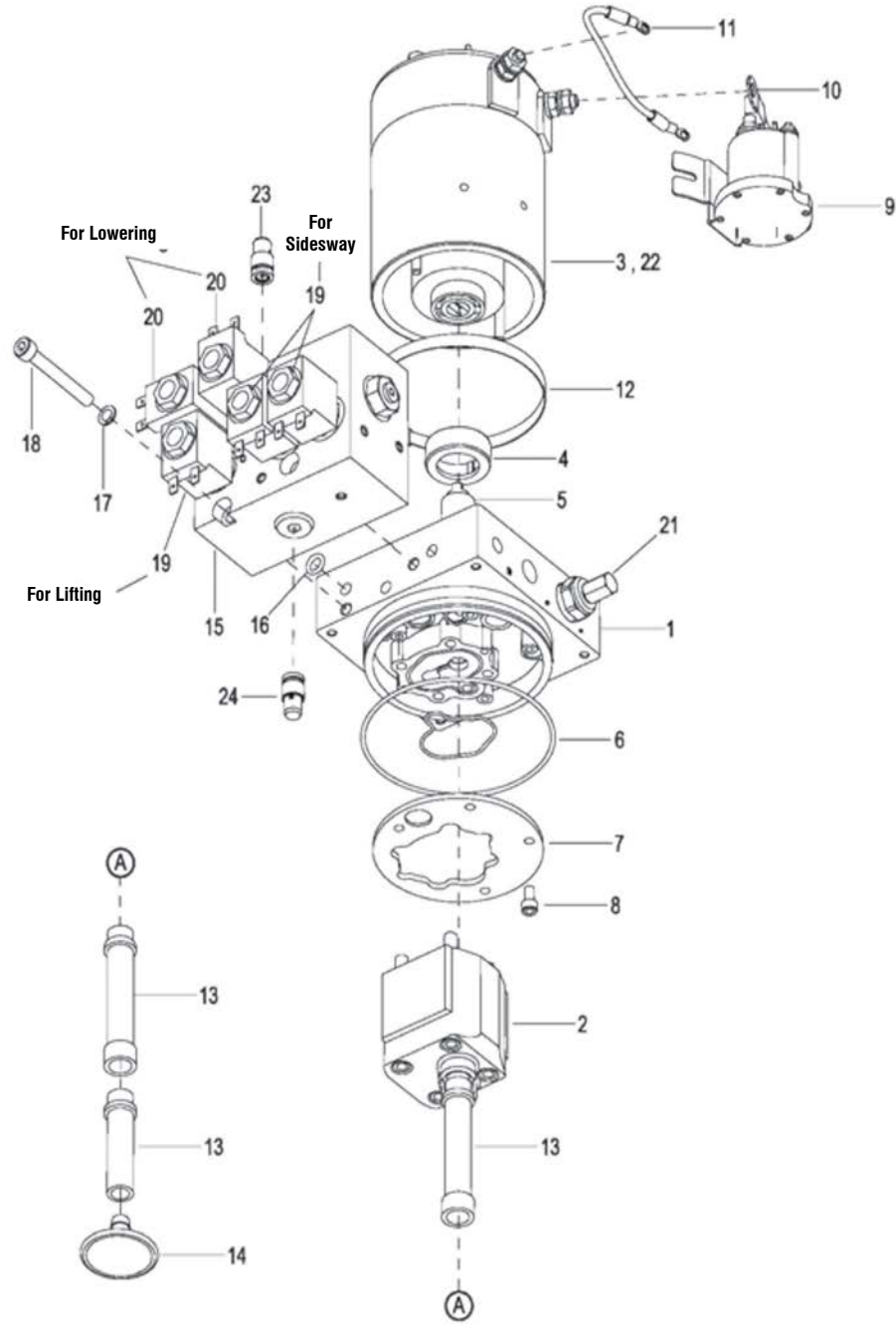

**PUMP AND MOTOR ASSEMBLY (USED WHEN SIDE SHIFT OPTION ON TRUCK)**

INDEX NO.	PART NO.	PART NAME	NO. REQ.	NOTES
1	2320-421001-00	ADAPTER	1	
2	2320-421002-00	PUMP	1	
3	2130-470002-40	MOTOR	1	
4	2320-421004-00	BUSH	1	
5	2320-421005-00	COUPLING	1	
6	2320-421006-00	SEAL KIT	1	
7	2320-421007-00	FILTER SCREEN	1	
8	0000-000077-00	SCREW M6 x 12	4	
9	2320-421008-00	RELAY	1	
10	2320-421009-00	CABLE INSULATED	1	
11	2320-421010-00	WIRE	1	
12	2320-421011-00	STEE CLAMP	1	
13	2320-421012-00	TUBE PLASTIC	3	
14	2320-421013-00	FILTER , STEEL	1	
15	2320-421014-00	MANIFOLD	1	
16	2320-421015-00	O-RING	2	
17	0000-000159-00	LOCKWASHER Ø8	2	
18	0000-000110-00	SCREW M8 x 65	2	
19	2320-421016-00	SOLENOID VALVE I	3	Used for Lift and Side Shift
20	2320-421017-00	SOLENOID VALVE II	2	Used for Lowering
21	2320-421018-00	RELIEF VALVE	1	
22	2130-470003-40	BRUSH	1	
23	2130-470001-40	FLOW CONTROL VALVE 6 L/MIN	1	
24	2320-421020-00	FLOW CONTROL VALVE 12 L/MIN	1	

FIGURE 12-31 HYDRAULIC SYSTEM (TELESCOPIC) - NOT WHEN SIDE SHIFT OPTION - USED UP TO 12-14-2011

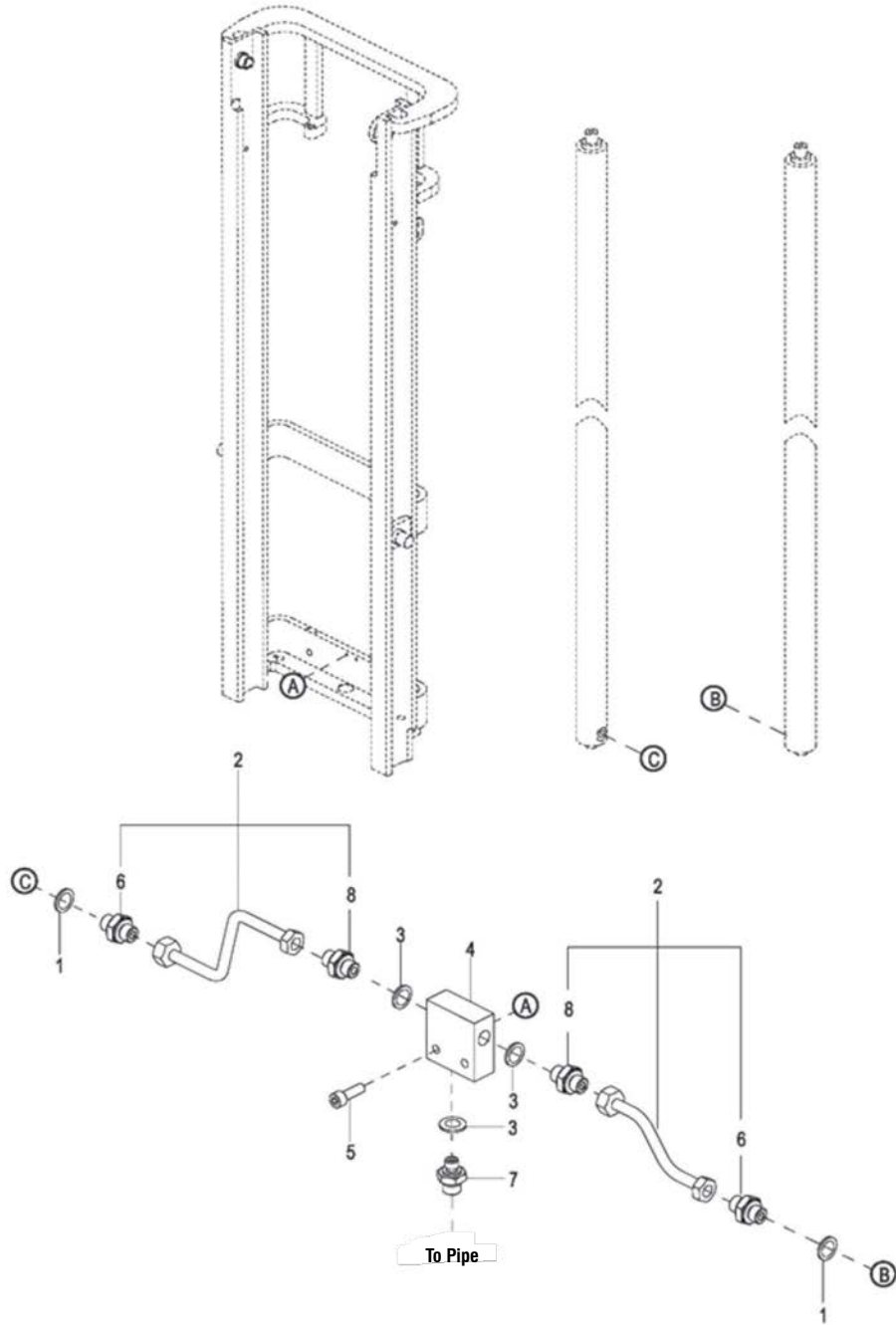



**HYDRAULIC SYSTEM (TELESCOPIC) - NOT WHEN SIDE SHIFT OPTION (USED UP TO 12-14-2011)**

INDEX NO.	PART NO.	PART NAME	NO. REQ.	NOTES
1	0000-000069-00	WASHER Ø16	2	
2	2130-400002-00-B	METALLIC PIPE ASSEMBLY	2	
3	0000-000044-00	WASHER Ø14	5	
4	2130-400001-00	BLOCK TEE	1	
5	0000-000154-00	SCREW M8 x 35	2	
6	2801-161601-00	CONNECTOR G1/4-M16 x 1.5	2	
7	2702-141600-00	CONNECTOR G1/4-M16 x 1.5	1	
8	2802-141601-00	CONNECTOR M16 x 1.5-M16 x 1.5	2	

FIGURE 12-32 HYDRAULIC SYSTEM (TELESCOPIC) NOT WHEN SIDE SHIFT - USED BETWEEN 12-15-2011 AND 12-26-2012

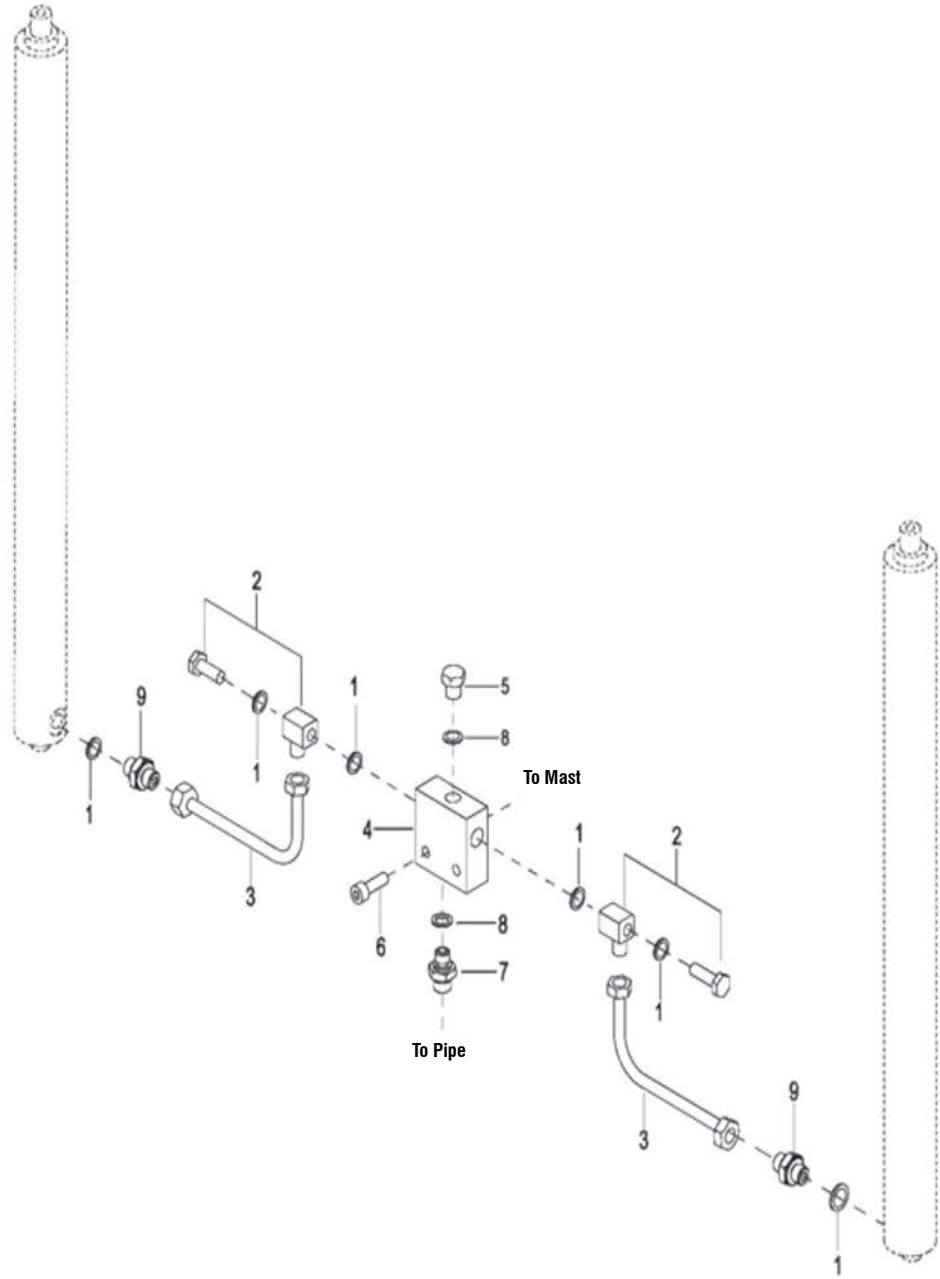

**HYDRAULIC SYSTEM (TELESCOPIC) - NOT WHEN SIDE SHIFT OPTION  
(USED BETWEEN 12-15-2011 AND 12-26-2012)**

INDEX NO.	PART NO.	PART NAME	NO. REQ.	NOTES
1	0000-000069-00	WASHER Ø16	6	
2	2805-160010-20	BOLT M16 x 1.5	2	
3	2130-400002-0A-B	METALLIC PIPE ASSEMBLY	2	
4	2125-400002-3A	BLOCK CROSS	1	
5	2712-141300-00	PLUG G1/4	1	
6	0000-000169-00	SCREW M8 x 30	2	
7	2702-141600-00	UNION	1	
8	0000-000044-00	WASHER Ø14	2	
9	2801-161601-00	CONNECTOR G1/4-M16 x 1.5	2	

FIGURE 12-33 HYDRAULIC SYSTEM (TELESCOPIC) NOT WHEN SIDE SHIFT - USED FROM 12-27-2012

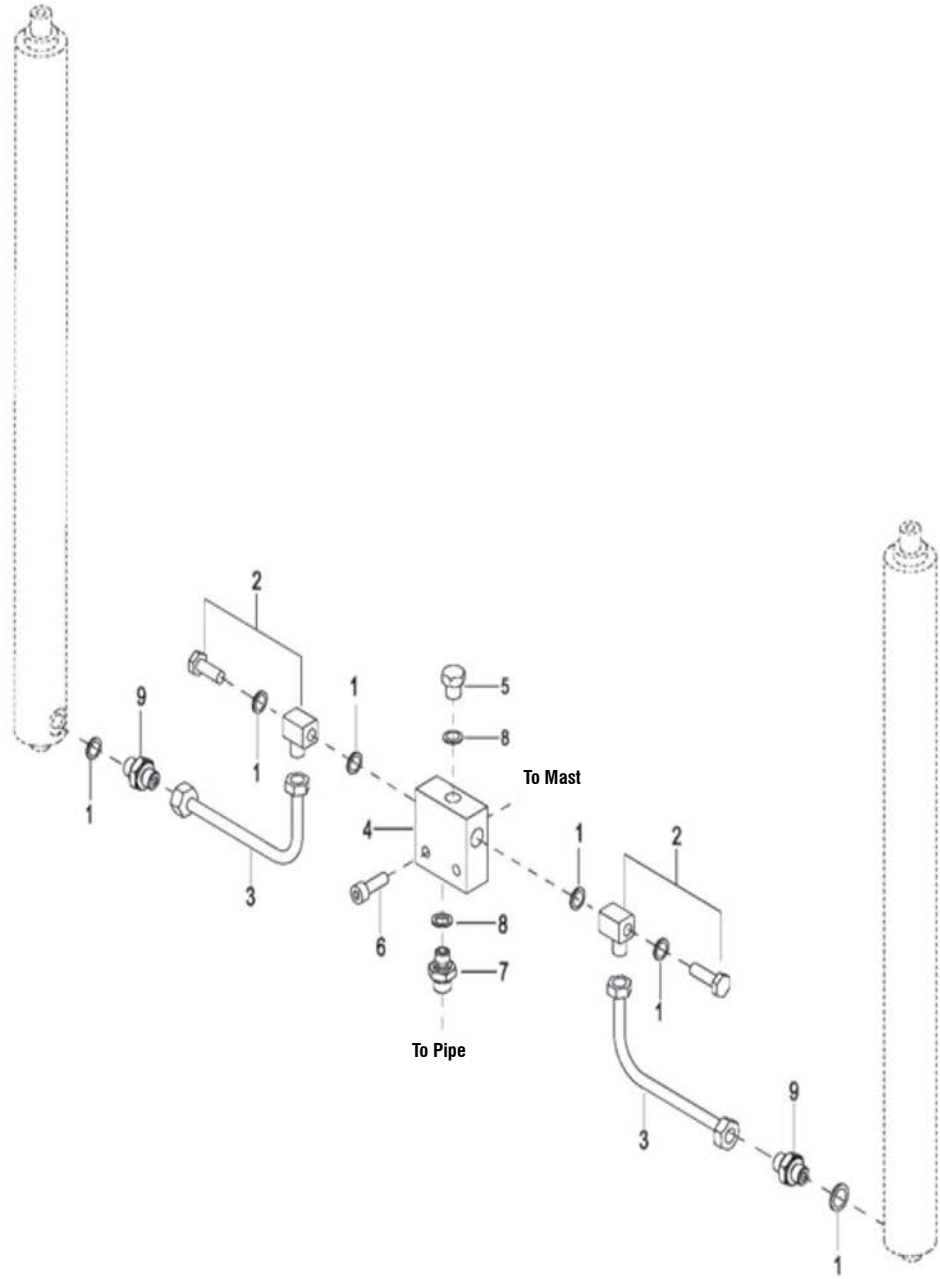

**HYDRAULIC SYSTEM (TELESCOPIC) - NOT WHEN SIDE SHIFT OPTION (USED FROM 12-27-2012)**

INDEX NO.	PART NO.	PART NAME	NO. REQ.	NOTES
1	0000-000069-00	WASHER Ø16	6	
2	2706-161600-00	CONNECTOR M16 x 1.5-M16 x 1.5	2	
3	2130-470000-00	METALLIC PIPE ASSEMBLY	2	
4	2125-400002-3A	BLOCK CROSS	1	
5	2712-141300-00	PLUG G1/4	1	
6	0000-000169-00	SCREW M8 x 30	2	
7	2702-141600-00	CONNECTOR G1/4-M16 x 1.5	1	
8	0000-000044-00	WASHER Ø14	2	
9	2701-161600-00	CONNECTOR M16 x 1.5-M16 x 1.5	2	

FIGURE 12-34 HYDRAULIC SYSTEM (TELESCOPIC) - USED WHEN SIDE SHIFT OPTION

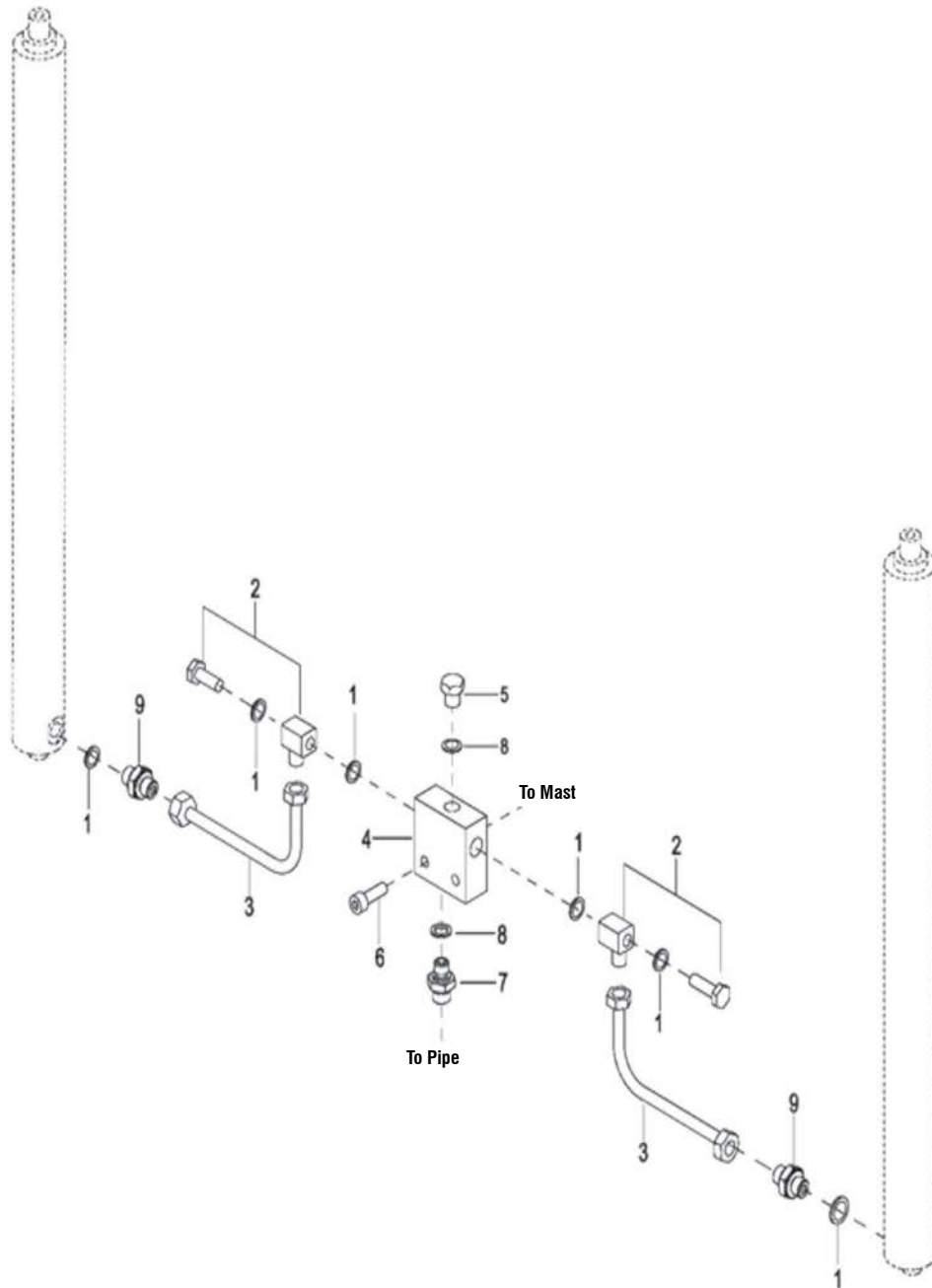

**HYDRAULIC SYSTEM (TELESCOPIC) - USED WHEN SIDE SHIFT OPTION**

INDEX NO.	PART NO.	PART NAME	NO. REQ.	NOTES
1	0000-000069-00	WASHER Ø16	6	
2	2706-161600-00	CONNECTOR M16 x 1.5-M16 x 1.5	2	
3	2130-470000-00	METALLIC PIPE ASSEMBLY	2	
4	2125-400002-3A	VALVE BLOCK	1	
5	2712-141300-00	PLUG G1/4	1	
6	0000-000169-00	SCREW M8 x 30	2	
7	2702-141600-00	CONNECTOR G1/4-M16 x 1.5	1	
8	0000-000044-00	WASHER Ø14	4	
9	2701-161600-00	CONNECTOR M16 x 1.5-M16 x 1.5	2	
10	3218-724000-00	METAL TUBE	1	
11	2130-440000-10-01	OIL PIPE	2	Used for lift height 104" - Telescopic
11a	2130-440000-10-02	OIL PIPE	2	Used for lift height 126" - Telescopic
11b	2130-440000-10-03	OIL PIPE	2	Used for lift height 142" - Telescopic
12	3215-860300-10	CONNECTOR M14 x 1.5-M14 x 1.5	2	
13	2130-450000-10	OIL PIPE	2	
14	2706-141400-00	CONNECTOR M14 x 1.5-M14 x 1.5	2	
15	0000-000109-00	SCREW M8 x 16	2	
16	0000-000159-00	LOCKWASHER Ø8	2	
17	0000-000176-00	FLATWASHER Ø8	2	

FIGURE 12-35 HYDRAULIC SYSTEM (TRIMAST) - NOT WHEN SIDE SHIFT OPTION - USED UP TO 12-14-2011

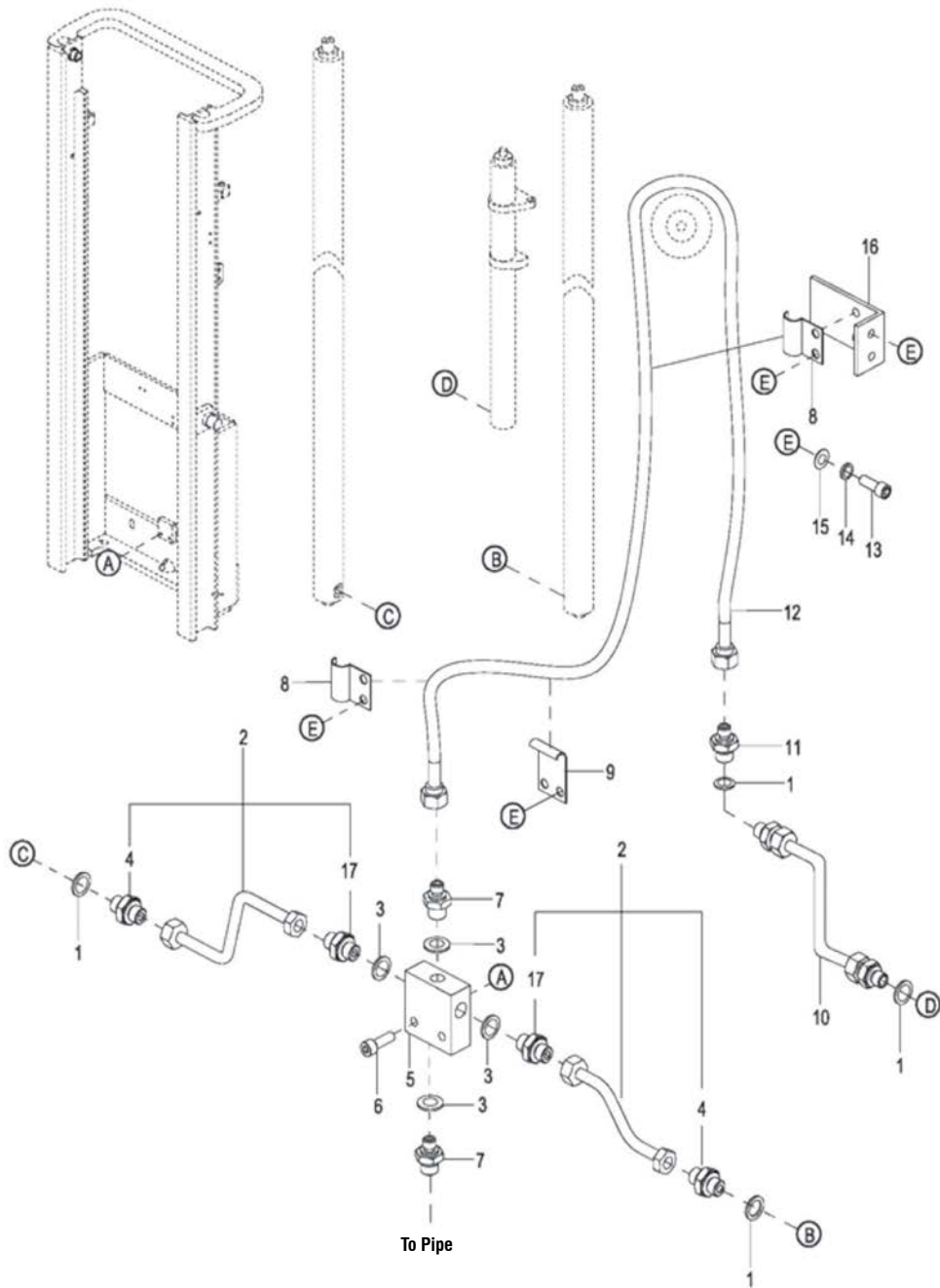



**HYDRAULIC SYSTEM (TRIMAST) - NOT WHEN SIDE SHIFT OPTION (USED UP TO 12-14-2011)**

INDEX NO.	PART NO.	PART NAME	NO. REQ.	NOTES
1	0000-000069-00	WASHER Ø16	5	
2	2125-400001-30-B	METALLIC PIPE ASSEMBLY	2	
3	0000-000044-00	WASHER Ø14	4	
4	2801-161601-00	CONNECTOR M16 x 1.5-M16 x 1.5	2	
5	2125-400002-30	VALVE BLOCK	1	
6	0000-000154-00	SCREW M8 x 35	2	
7	2702-141600-00	CONNECTOR G1/4-M16 x 1.5	2	
8	2125-400003-30	HARNESS CLAMP	2	
9	2125-400006-30	HARNESS CLAMP II	1	
10	2125-400007-30-B	METALLIC PIPE ASSEMBLY	1	
11	2701-161600-00	CONNECTOR M16 x 1.5-M16 x 1.5	1	
12	2125-440000-30-01	HOSE	1	Used for lift height 157" - TRIMAST
12a	2125-440000-30-02	HOSE	1	Used for lift height 177" - TRIMAST
13	0000-000109-00	SCREW M8 x 16	8	
14	0000-000159-00	LOCKWASHER Ø8	8	
15	0000-000176-00	FLATWASHER Ø8	8	
16	2125-400004-30	CLAMP BRACKET	1	
17	2802-141601-00	CONNECTOR G1/4-M16 x 1.5	2	

FIGURE 12-36 HYDRAULIC SYSTEM (TRIMAST) NOT WHEN SIDE SHIFT - USED BETWEEN 12-15-2011 AND 12-26-2012

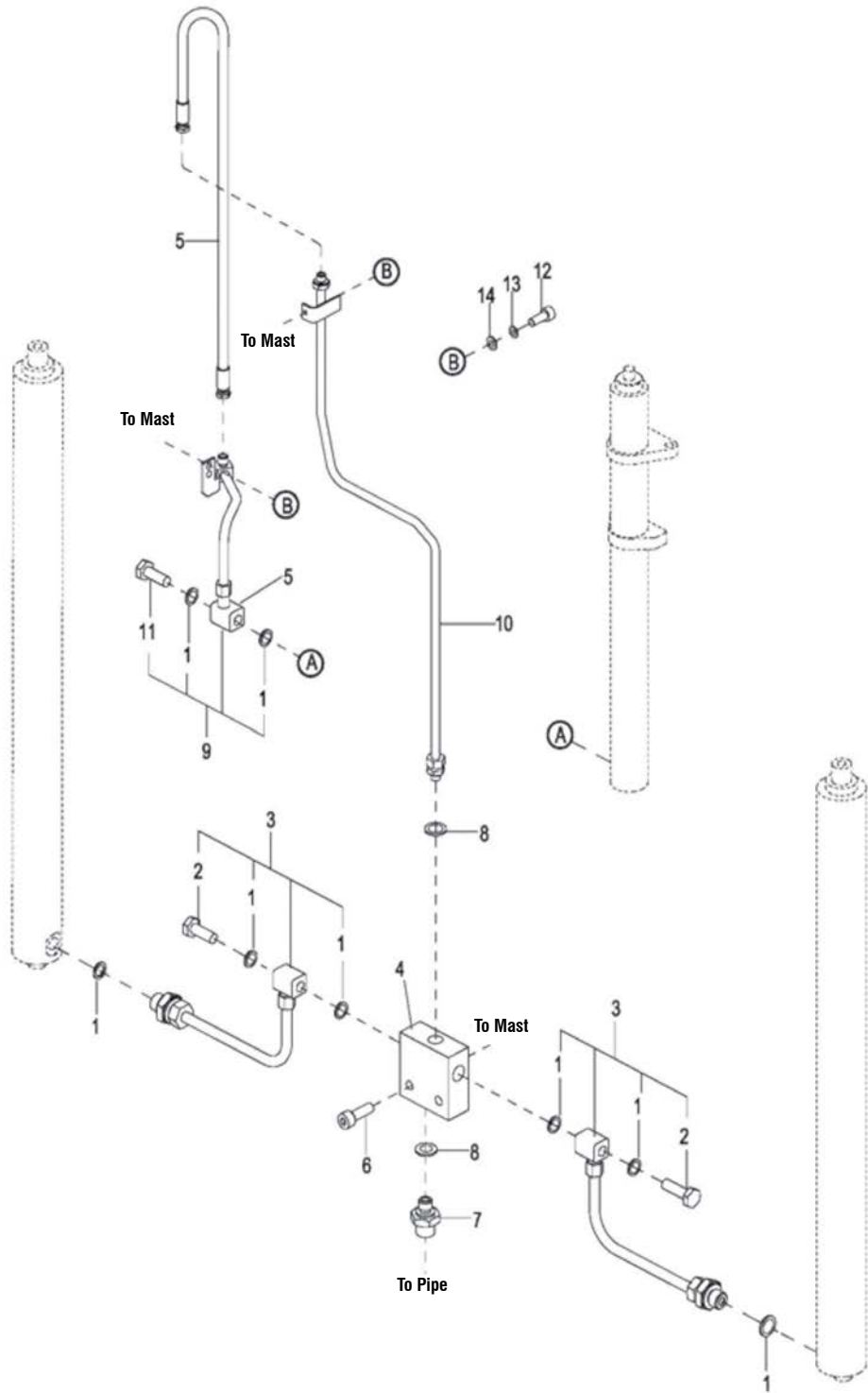

**HYDRAULIC SYSTEM (TRIMAST) - NOT WHEN SIDE SHIFT OPTION (USED BETWEEN 12-15-2011 AND 12-26-2012)**

INDEX NO.	PART NO.	PART NAME	NO. REQ.	NOTES
1	0000-000069-00	WASHER Ø16	8	
2	2805-160010-20	BOLT M16 x 1.5	2	
3	2130-400002-0A-B	METALLIC PIPE ASSEMBLY	2	
4	2125-400002-30	VALVE BLOCK	1	
5	2125-440000-3A-01	HOSE	1	Used for lift height 157" - TRIMAST
5a	2125-440000-3A-02	HOSE	1	Used for lift height 177" - TRIMAST
6	0000-000169-00	SCREW M8 x 30	2	
7	2702-141600-00	UNION	1	
8	0000-000044-00	WASHER Ø14	2	
9	2125-430000-3A-B	METALLIC PIPE ASSEMBLY	1	
10	2125-450000-30-B	METALLIC PIPE ASSEMBLY	1	
11	2805-160014-00	BOLT M16 x 1.5	1	
12	0000-000109-00	SCREW M8 x 16	3	
13	0000-000159-00	LOCKWASHER Ø8	3	
14	0000-000176-00	FLATWASHER Ø8	3	

FIGURE 12-37 HYDRAULIC SYSTEM (TRIMAST NOT WHEN SIDE SHIFT - USED FROM 12-27-2012)

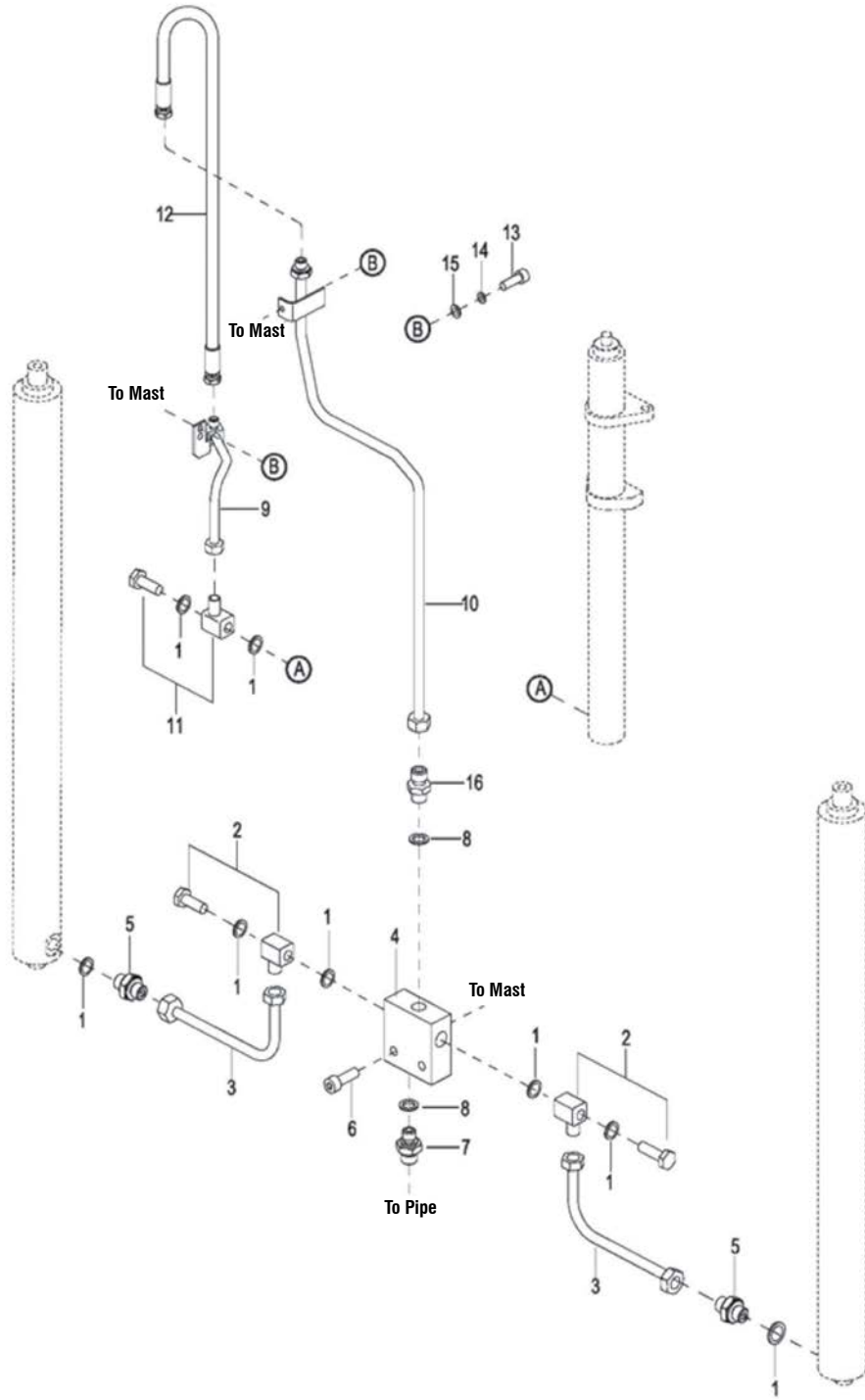

**HYDRAULIC SYSTEM (TRIMAST) - NOT WHEN SIDE SHIFT OPTION (USED FROM 12-27-2012)**

INDEX NO.	PART NO.	PART NAME	NO. REQ.	NOTES
1	0000-000069-00	WASHER Ø16	8	
2	2706-161600-00	CONNECTOR M16 x 1.5-M16 x 1.5	2	
3	2130-430000-30	METALLIC PIPE ASSEMBLY	2	
4	2125-400002-30	VALVE BLOCK	1	
5	2701-161600-00	CONNECTOR M16 x 1.5-M16 x 1.5	2	
6	0000-000169-00	SCREW M8 x 30	2	
7	2702-141600-00	CONNECTOR G1/4-M16 x 1.5	1	
8	0000-000044-00	WASHER Ø14	2	
9	2125-430000-3B	METALLIC OIL PIPE ASSEMBLY	1	
10	2125-450000-3A	METALLIC OIL PIPE ASSEMBLY	1	
11	2706-162000-10	CONNECTOR M16 x 1.5-M20 x 1.5	1	
12	2125-440000-3A-01	HOSE	1	Used for lift height 157" - TRIMAST
12a	2125-440000-3A-02	HOSE	1	Used for lift height 177" - TRIMAST
13	0000-000109-00	SCREW M8 x 16	3	
14	0000-000159-00	LOCKWASHER Ø8	3	
15	0000-000176-00	FLATWASHER Ø8	3	
16	2702-142000-00	CONNECTOR G1/4-M20 x 1.5	1	

FIGURE 12-38 HYDRAULIC SYSTEM (TRIMAST) - USED WHEN SIDE SHIFT OPTION

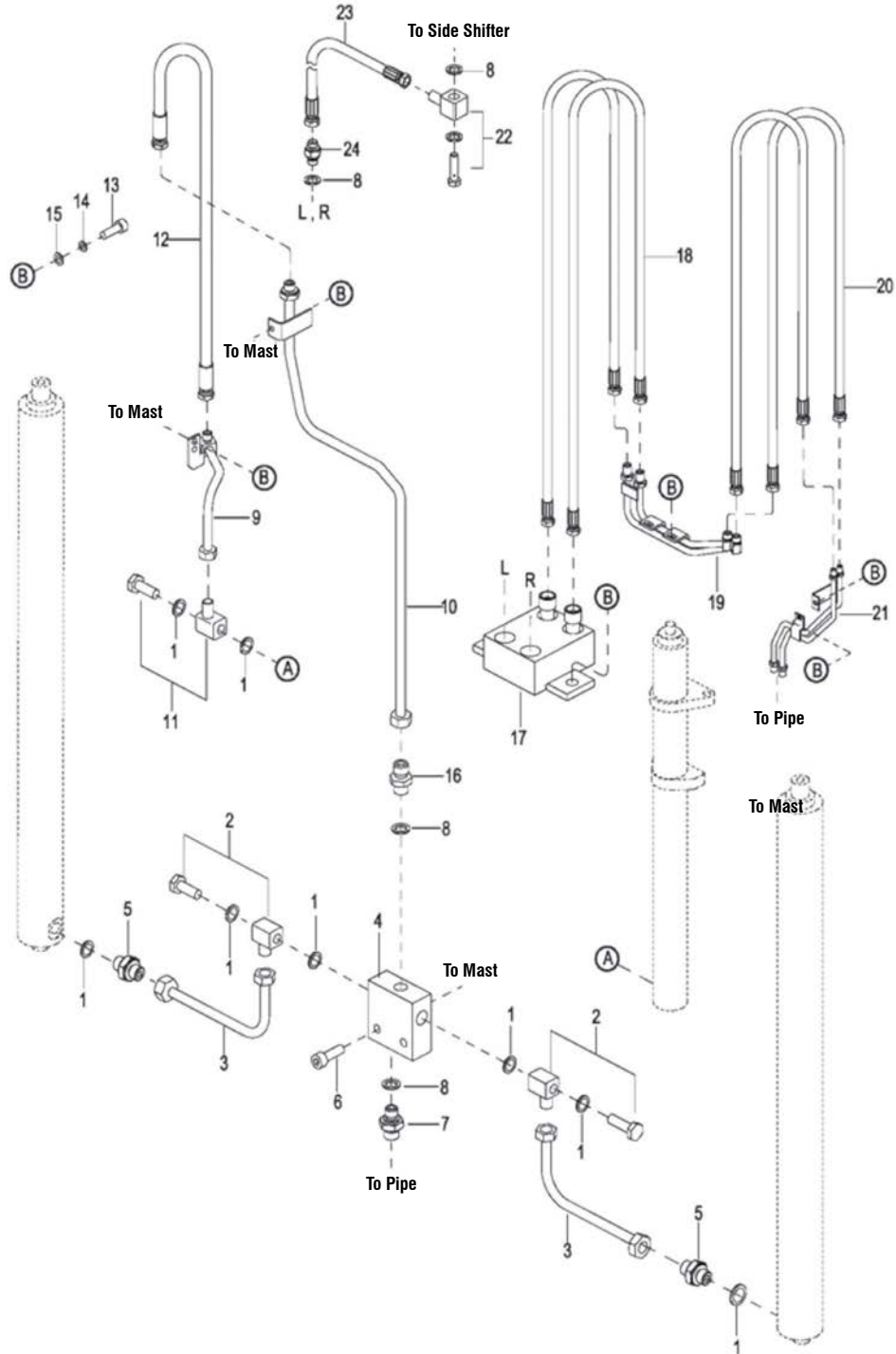

**HYDRAULIC SYSTEM (TRIMAST) - USED WHEN SIDE SHIFT OPTION**

INDEX NO.	PART NO.	PART NAME	NO. REQ.	NOTES
1	0000-000069-00	WASHER Ø16	8	
2	2706-161600-00	CONNECTOR M16 x 1.5-M16 x 1.5	2	
3	2130-430000-30	METALLIC PIPE ASSEMBLY	2	
4	2125-400002-30	VALVE BLOCK	1	
5	2701-161600-00	CONNECTOR M16 x 1.5-M16 x 1.5	2	
6	0000-000169-00	SCREW M8 x 30	2	
7	2702-141600-00	CONNECTOR G1/4-M16 x 1.5	1	
8	0000-000044-00	WASHER Ø14	8	
9	2125-430000-3B	METALLIC OIL PIPE ASSEMBLY	1	
10	2125-450000-3A	METALLIC OIL PIPE ASSEMBLY	1	
11	2706-162000-10	CONNECTOR M16 x 1.5-M20 x 1.5	1	
12	2125-440000-3A-01	HOSE	1	Used for lift height 157" - TRIMAST
12a	2125-440000-3A-02	HOSE	1	Used for lift height 177" - TRIMAST
13	0000-000109-00	SCREW M8 x 16	9	
14	0000-000159-00	LOCKWASHER Ø8	9	
15	0000-000176-00	FLATWASHER Ø8	9	
16	2702-142000-00	CONNECTOR G1/4-M20 x 1.5	1	
17	3215-860100-30	FOUR WAY VALVE	1	
18	2130-440000-40-01	OIL PIPE	2	Used for lift height 157" - TRIMAST
18a	2130-440000-40-02	OIL PIPE	2	Used for lift height 177" - TRIMAST
19	3215-860200-30	METAL TUBE	1	
20	2130-450000-40-01	OIL PIPE	2	Used for lift height 157" - TRIMAST
20a	2130-450000-40-02	OIL PIPE	2	Used for lift height 177" - TRIMAST
21	3215-860500-30	METAL TUBE	1	
22	2706-141400-00	CONNECTOR M14 x 1.5-M14 x 1.5	2	
23	2130-430000-40	OIL PIPE	2	
24	2701-141400-00	CONNECTOR M14 x 1.5-M14 x 1.5	2	

FIGURE 12-39 LIFT CYLINDER (TELESCOPIC)

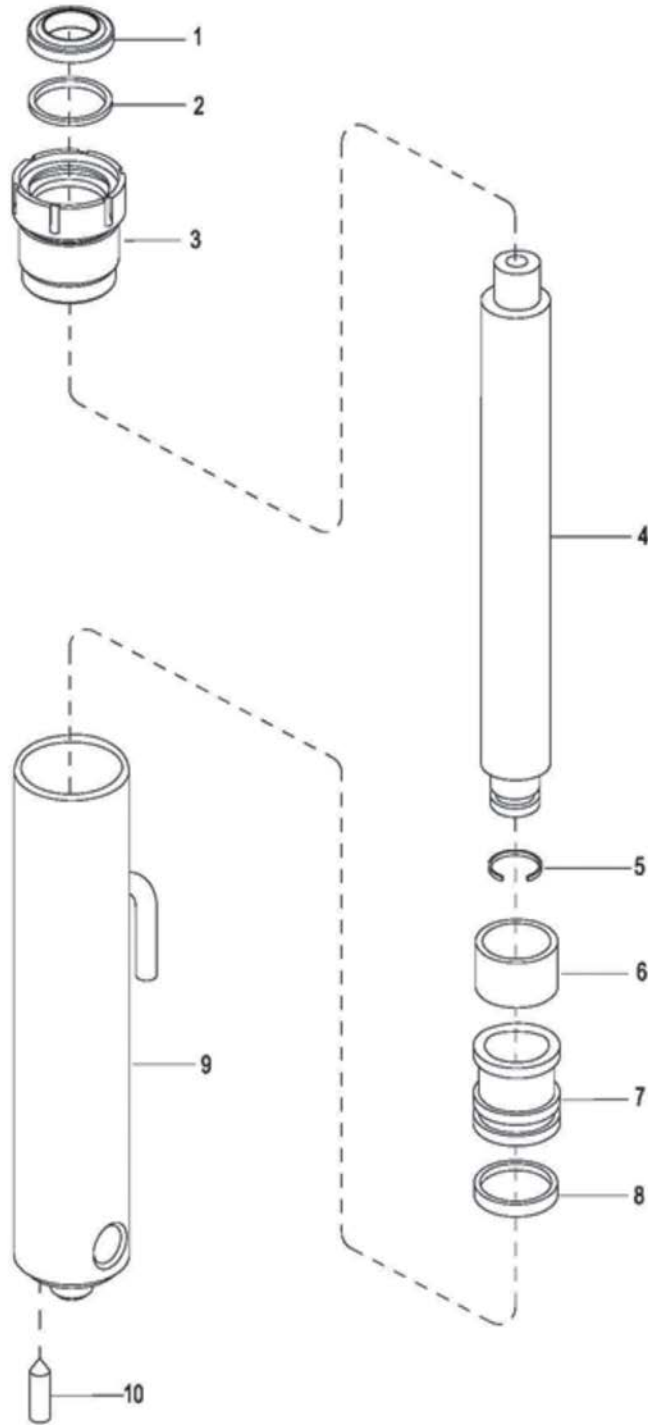



**LIFT CYLINDER (TELESCOPIC)**

INDEX NO.	PART NO.	PART NAME	NO. REQ.	NOTES
--	2130-410000-00-01	LIFT CYLINDER ASSEMBLY	1	Used for lift height 104" - Telescopic
--	2130-410000-00-02	LIFT CYLINDER ASSEMBLY	1	Used for lift height 126" - Telescopic
--	2130-410000-00-03	LIFT CYLINDER ASSEMBLY	1	Used for lift height 142" - Telescopic
KIT	2130-2BG	SEAL KIT FOR LIFT CYLINDER	1	Incl. Pos. # 1, 2 and 8
1	0000-000084-00	RING WIPER 35 x 43 x 5-6.5	1	
2	0000-000370-00	O-RING 40 x 3.1	1	
3	1220-420001-0A	CAP	1	
4	2130-410001-00-01	PISTON ROD	1	Used for lift height 104" - Telescopic
4a	2130-410001-00-02	PISTON ROD	1	Used for lift height 126" - Telescopic
4b	2130-410001-00-03	PISTON ROD	1	Used for lift height 142" - Telescopic
5	2130-410003-00	COLLAR	1	
6	2130-410004-00	RING BACK UP	1	
7	2130-410002-00	PISTON	1	
8	0000-000132-00	ROD PACKING 30 x 40 x 6	1	
9	2130-411000-00-01	CYLINDER TUBE	1	Used for lift height 104" - Telescopic
9	2130-411000-00-02	CYLINDER TUBE	1	Used for lift height 126" - Telescopic
9	2130-411000-00-03	CYLINDER TUBE	1	Used for lift height 142" - Telescopic
10	2125-410006-30	PIN	1	

Figure 12-40 Free Lift Cylinder (TRIMAST)

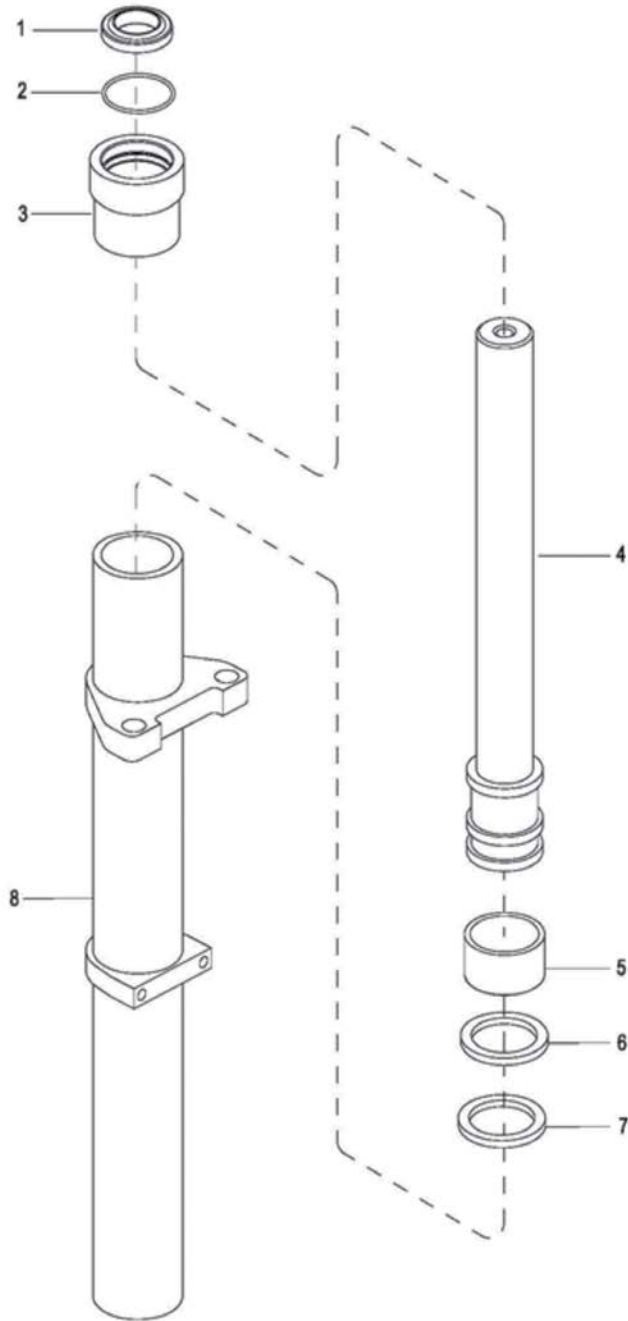

**FREE LIFT CYLINDER (TRIMAST)**

INDEX NO.	PART NO.	PART NAME	NO. REQ.	NOTES
--	2130-420000-30-01	LIFT CYLINDER ASSEMBLY	1	Used for lift height 157" - TRIMAST
--	2130-420000-30-02	LIFT CYLINDER ASSEMBLY	1	Used for lift height 177" - TRIMAST
KIT	2130-3ZG	KIT	1	Inc. pos. # 1, 2 and 7
1	0000-000045-00	RING WIPER 55 x 63 x 5-6.5	1	
2	0000-000690-00	O-RING 60 x 3.1	1	
3	2130-420002-30	CAP	1	
4	2130-420001-30-01	PISTON ROD	1	Used for lift height 157" - TRIMAST
4a	2130-420001-30-02	PISTON ROD	1	Used for lift height 177" - TRIMAST
5	2130-420003-30	RING BACK UP 70 x 65 x 20	1	
6	0000-000698-00	SNAP RING 53 x 63 x 2	1	
7	0000-000699-00	COLLAR 53 x 63 x 6	1	
8	2130-421000-30-01	CYLINDER TUBE	1	Used for lift height 157" - TRIMAST
8a	2130-421000-30-02	CYLINDER TUBE	1	Used for lift height 177" - TRIMAST

FIGURE 12-41 SECONDARY LIFT CYLINDER (TRIMAST)

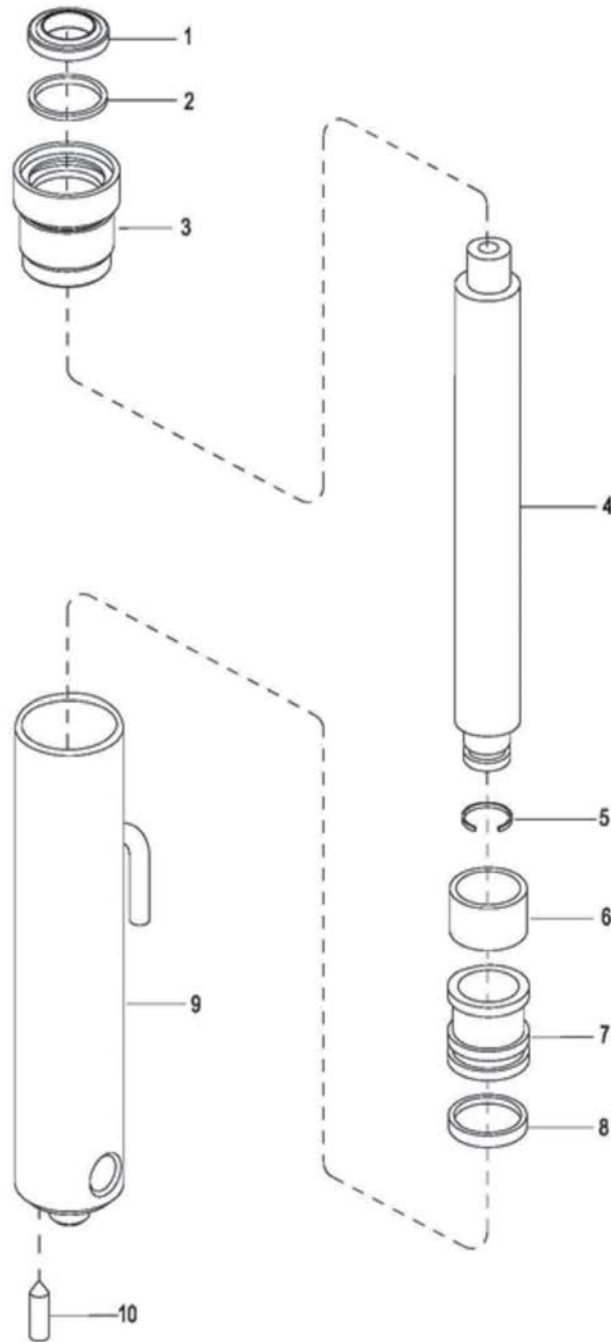

**SECONDARY LIFT CYLINDER (TRIMAST)**

INDEX NO.	PART NO.	PART NAME	NO. REQ.	NOTES
--	2130-410000-30-01	LIFT CYLINDER ASSEMBLY	1	Used for lift height 157" - TRIMAST (2 per truck)
--	2130-410000-30-02	LIFT CYLINDER ASSEMBLY	1	Used for lift height 177" - TRIMAST (2 per truck)
KIT	2130-3BG	SEAL KIT FOR LIFT CYLINDER	1	Incl. pos. # 1, 2 and 8
1	0000-000084-00	RING WIPER 35 x 43 x 5-6.5	1	
2	0000-000370-00	O-RING 40 x 3.1	1	
3	1220-420001-0A	CAP	1	
4	2130-410001-30-01	PISTON ROD	1	Used for lift height 157" - TRIMAST
4a	2130-410001-30-02	PISTON ROD	1	Used for lift height 177" - TRIMAST
5	2130-410003-30	COLLAR	1	
6	2130-410004-30	RING BACK UP	1	
7	2130-410002-30	PISTON	1	
8	0000-000132-00	ROD PACKING	1	
9	2130-411000-30-01	CYLINDER TUBE	1	Used for lift height 157" - TRIMAST
9a	2130-411000-30-02	CYLINDER TUBE	1	Used for lift height 177" - TRIMAST
10	2125-410006-30	PIN	1	

FIGURE 12-42 ELECTRICAL SYSTEM - USED UP TO SERIAL NUMBER S2112138

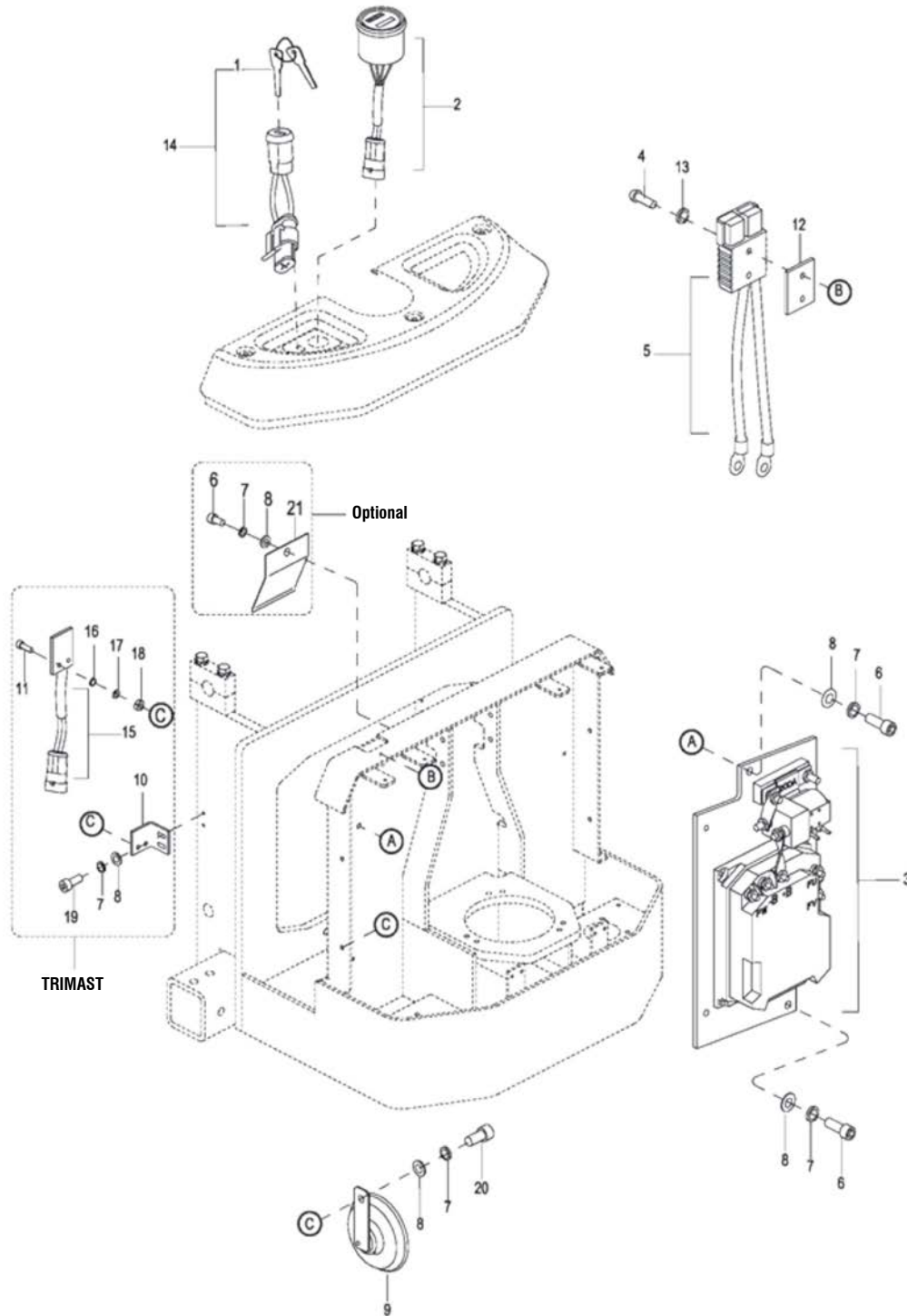

**ELECTRICAL SYSTEM USED UP TO SERIAL NUMBER S2112138**

INDEX NO.	PART NO.	PART NAME	NO. REQ.	NOTES
1	1120-500016-00	KEY	1	
2	See electrical panel section	BDI ASSEMBLY WITH HOUR METER	1	3 Pin Assembly BDI not sold separately
3	0000-000498-00	CONTROL BOARD ASSEMBLY	1	
4	0000-000498-00	SCREW M6 x 30	2	
5	2130-531000-00	CONNECTOR BATTERY ASSEMBLY	1	
6	0000-000321-00	SCREW M8 x 20	2	
7	0000-000159-00	LOCKWASHER Ø8	5	
8	0000-000194-00	FLATWASHER Ø8	5	
9	1120-500003-00	HORN	1	
10	2114-500001-00	SENSOR BRACKET	1	
11	0000-000378-00	SCREW M4 x 16	2	
12	1120-112008-00	PLATE	1	
13	0000-000056-00	LOCKWASHER Ø6 2	2	
14	1220-520002-0C	2 WAY SWITCH ASSEMBLY	1	
15	2130-520003-30	PROXIMITY SWITCHES WIRING	1	Used on TRIMAST
16	0000-000122-00	LOCKWASHER Ø4	2	
17	0000-000702-00	FLATWASHER Ø4	2	
18	0000-000139-00	NUT M4	2	
19	0000-000109-00	SCREW M8 x 16	2	
20	0000-000433-00	SCREW M8 x 12	1	
21	1120-100003-00	BATTERY CLIP	1	

**FIGURE 12-43 ELECTRICAL SYSTEM - USED FROM SERIAL NUMBER S2112139**

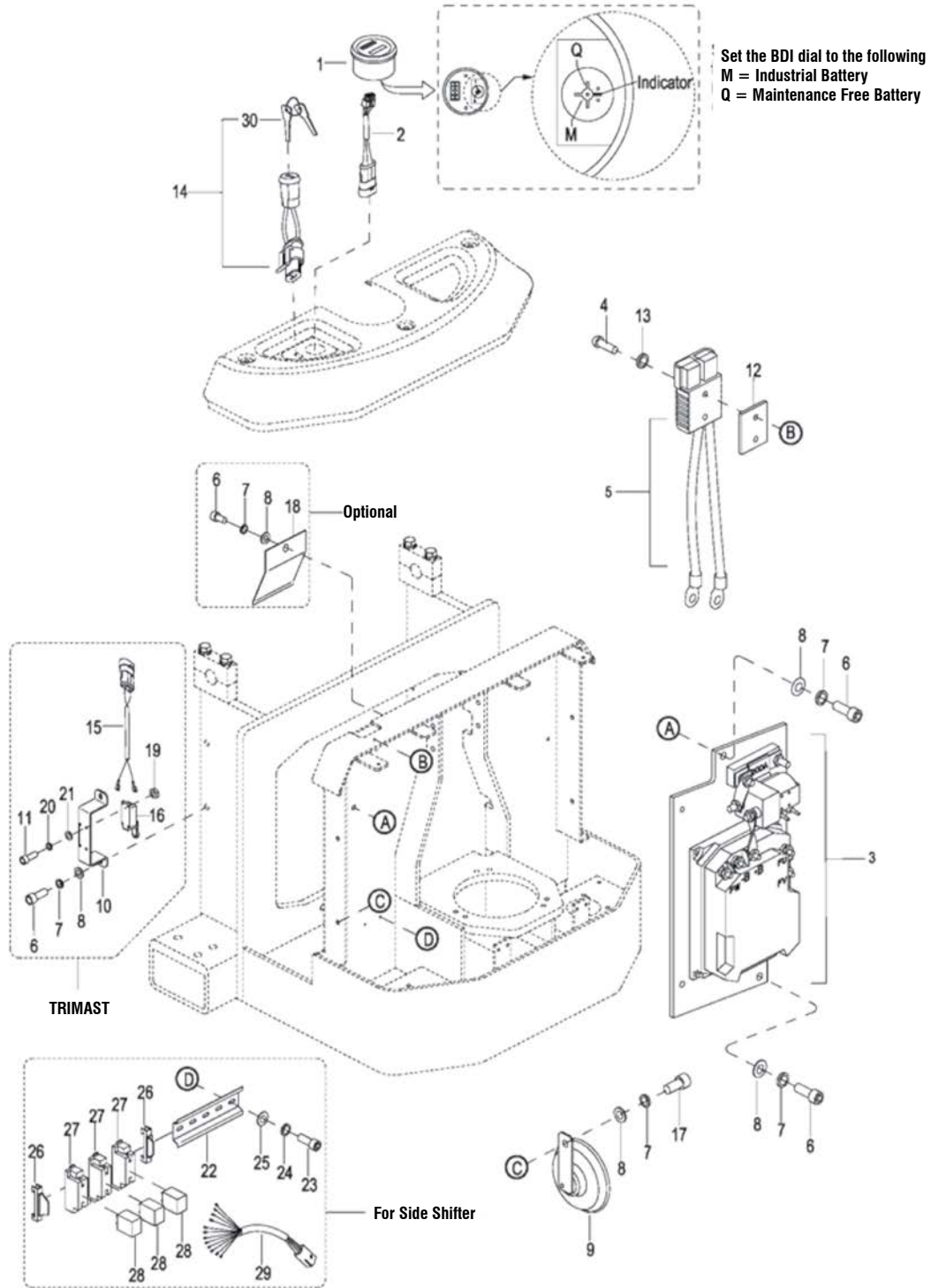



**ELECTRICAL SYSTEM USED FROM SERIAL NUMBER S2112139**

INDEX NO.	PART NO.	PART NAME	NO. REQ.	NOTES
1	1220-520007-0C	BDI ASSEMBLY WITH HOUR METER (SEE NOTE)	1	3 Pin Assembly BDI not sold separately - Used up to 04- 14-2012
1a	1115-510006-20	BATTERY INDICATOR (BDI) WITH HOUR METER	1	Used from 04-15-2012: Set the BDI dial to the following: M = Industrial Battery Q = Maint.Free Battery
2	1220-520007-0D	BDI WIRE HARNESS	1	Used from 04-15-2012:
3	--	CONTROL BOARD ASSEMBLY	1	See Electrical Panel Section
4	0000-000498-00	SCREW M6 x 30	2	
5	2130-531000-00	CONNECTOR BATTERY ASSEMBLY	1	
6	0000-000321-00	SCREW M8 x 20	5	
7	0000-000159-00	LOCKWASHER Ø8	6	Used on TRIMAST
8	0000-000194-00	FLATWASHER Ø8	6	Used on TRIMAST
9	1120-500003-00	HORN	1	
10	2125-500001-3A	SENSOR BRACKET	1	Used on TRIMAST up to Serial number 324170029
10a	2125-500003-30	SENSOR BRACKET	1	Used on TRIMAST from serial number 324170030
11	0000-000004-00	SCREW M5 x 12	4	Used on TRIMAST
12	1120-112008-00	PLATE	1	
13	0000-000056-00	LOCKWASHER Ø6	2	
14	1220-520002-0C	2 WAY SWITCH ASSEMBLY	1	Used up to serial number S2119006
14a	1220-520002-1C	2 WAY SWITCH ASSEMBLY	1	Used from serial number S2119007
15	2130-520003-3A	PROXIMITY SWITCH WIRING	1	Used on TRIMAST
16	2125-500003-00	PROXIMITY SWITCH 8108	1	Used on TRIMAST
17	0000-000433-00	SCREW M8 x 12	1	
18	1120-100003-00	BATTERY CLIP	1	
19	0000-000546-00	NUT M5	4	
20	0000-000206-00	LOCKWASHER Ø5	4	Used on TRIMAST
21	0000-000390-00	FLATWASHER Ø5	4	Used on TRIMAST
22	2110-500002-00	RELAY BRACKET	1	Used when side shift option
23	0000-000009-00	SCREW M4 x 12	2	Used when side shift option
24	0000-000122-00	LOCKWASHER Ø4	2	Used when side shift option
25	0000-000702-00	FLATWASHER Ø4	2	Used when side shift option
26	2110-500003-00	RELAY SET CLIP	2	Used when side shift option
27	2110-500004-00	RELAY SET	3	Used when side shift option
28	2110-500005-00	RELAY	3	Used when side shift option
29	2320-520005-00	RELAY WIRE HARNESS	1	Used when side shift option
30	1120-500016-00	KEY	1	Used up to serial number S2119006
30a	1120-500016-10	KEY	1	Used from serial number S2119007

FIGURE 12-44 ELECTRICAL PANEL

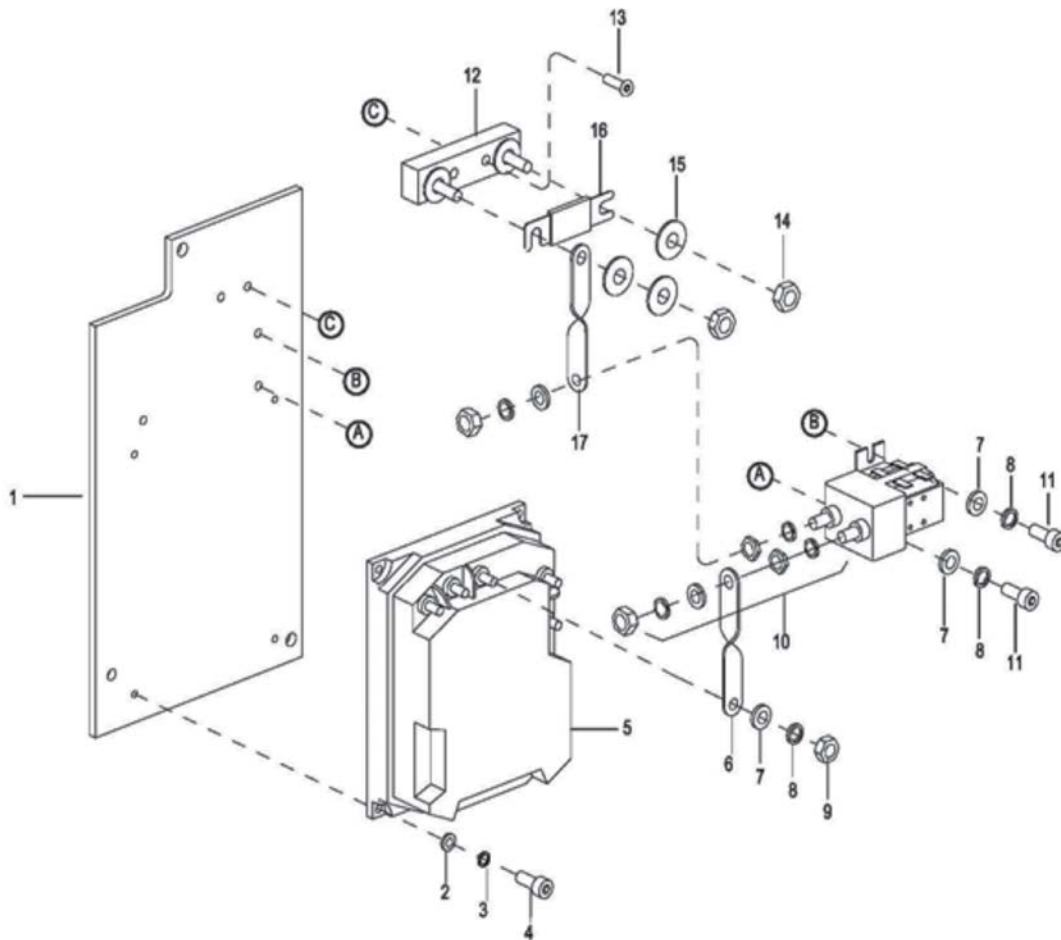

**ELECTRICAL PANEL**

INDEX NO.	PART NO.	PART NAME	NO. REQ.	NOTES
1	2125-510001-00	BOARD	1	
2	0000-000128-00	FLATWASHER Ø5	4	
3	0000-000206-00	LOCKWASHER Ø5	4	
4	0000-000004-00	SCREW M5 x 12	4	
5	907300-03	CONTROLLER	1	
6	1120-530007-00	COPPER CONDUCTOR	1	
7	0000-000123-00	FLATWASHER Ø6	7	
8	0000-000056-00	LOCKWASHER Ø6	7	
9	0000-000166-00	NUT M6	5	
10	1120-500005-00	CONTACTOR	1	
11	0000-000077-00	SCREW M6 x 12	2	
12	1120-540001-00	STAND	1	
13	0000-000077-00	SCREW M6 x 12	2	
14	0000-000196-00	NUT M8	2	
15	0000-000210-00	FLATWASHER Ø8	3	
16	1120-540002-00	FUSE 200A	1	
17	1120-530006-00	COPPER CONDUCTOR	1	

FIGURE 12-45 DRIVE MOTOR

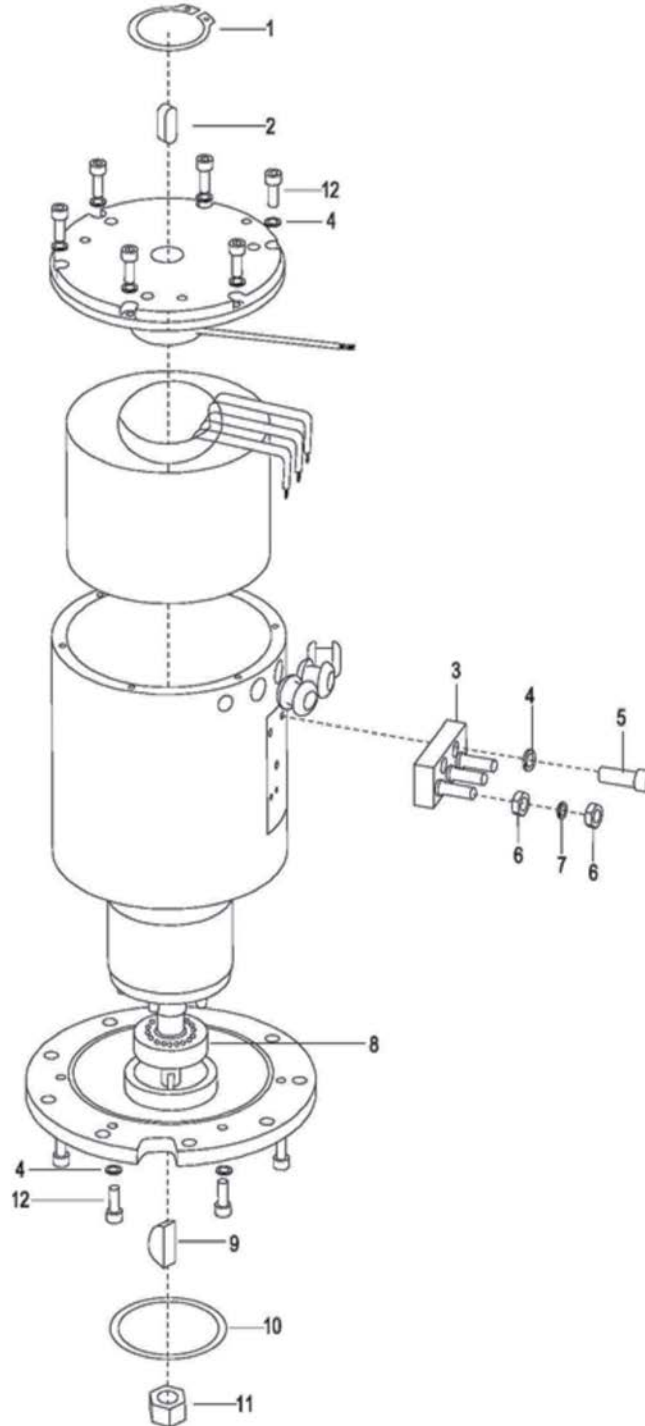

**DRIVE MOTOR**

INDEX NO.	PART NO.	PART NAME	NO. REQ.	NOTES
1	0000-000293-00	RETAINING RING	2	
2	0000-000226-00	KEY 6 x 6 x 16	1	
3	1120-220001-00	TERMINAL BLOCK	1	
4	0000-000206-00	LOCKWASHER Ø5	17	
5	0000-000117-00	SCREW M5 x 10	2	
6	0000-000166-00	NUT M6	6	
7	0000-000056-00	LOCKWASHER Ø6	6	
8	1120-220002-00	BEARING	1	
9	0000-000204-00	KEY	1	
10	0000-000409-00	O-RING 63 x 3.55	1	
11	0000-000436-00	NUT M12	1	
12	0000-000323-00	SCREW M5 x 16	14	

FIGURE 12-46 WIRING HARNESS (NOT USED WHEN SIDE SHIFT OPTION)

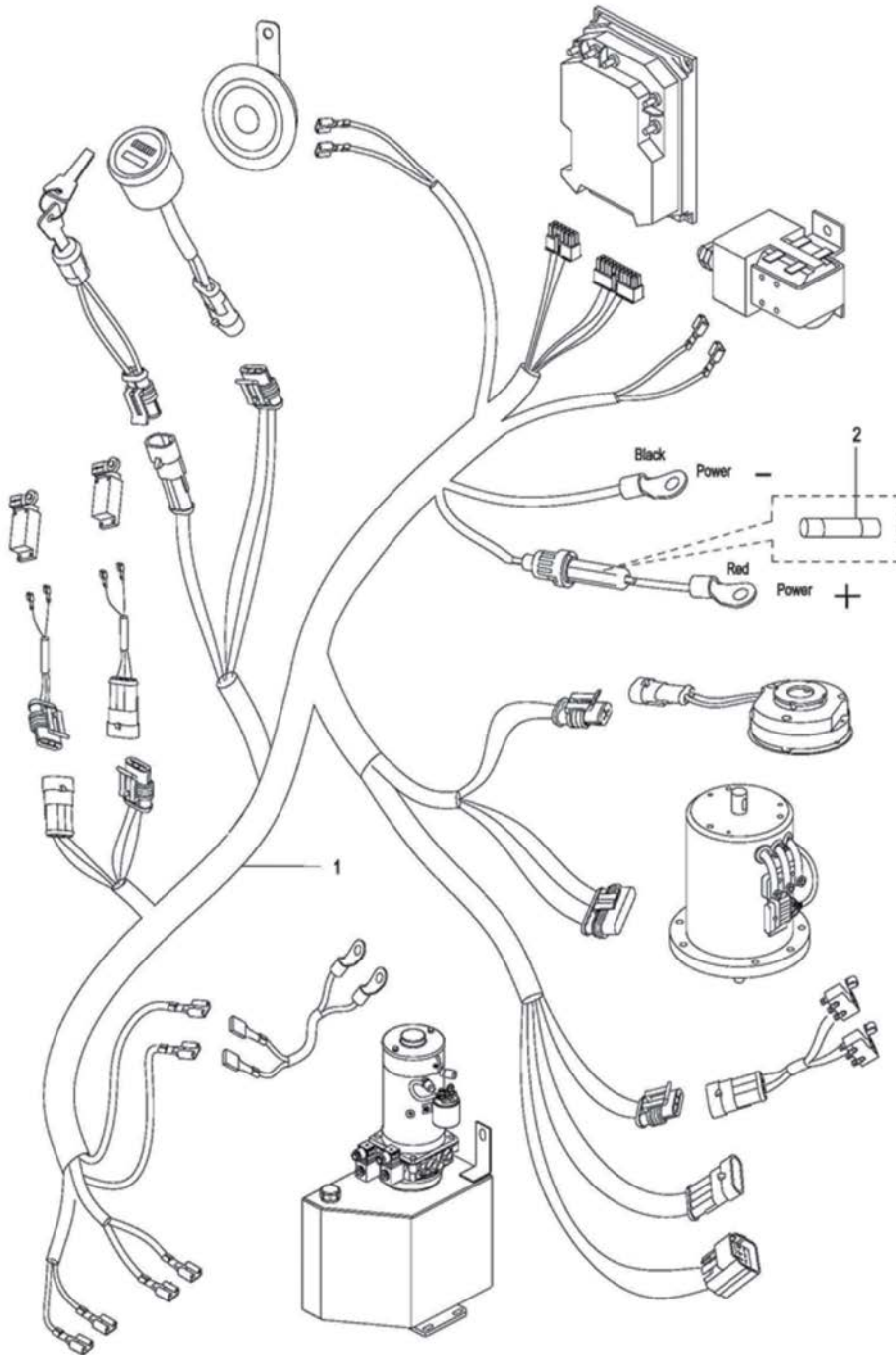

**WIRING HARNESS (NOT USED WHEN SIDE SHIFT OPTION)**

INDEX NO.	PART NO.	PART NAME	NO. REQ.	NOTES
1	2130-520001-00	WIRING HARNESS	1	
1a	1220-520014-00	WIRE	1	Not Pictured: If changing from old hydraulic unit (used up to S2117012) to new Bucher unit (used from serial number S2117013) you have to add this wire.
2	1120-500010-00	FUSE 10A	1	

FIGURE 12-47 WIRING HARNESS (USED WHEN SIDE SHIFT OPTION)

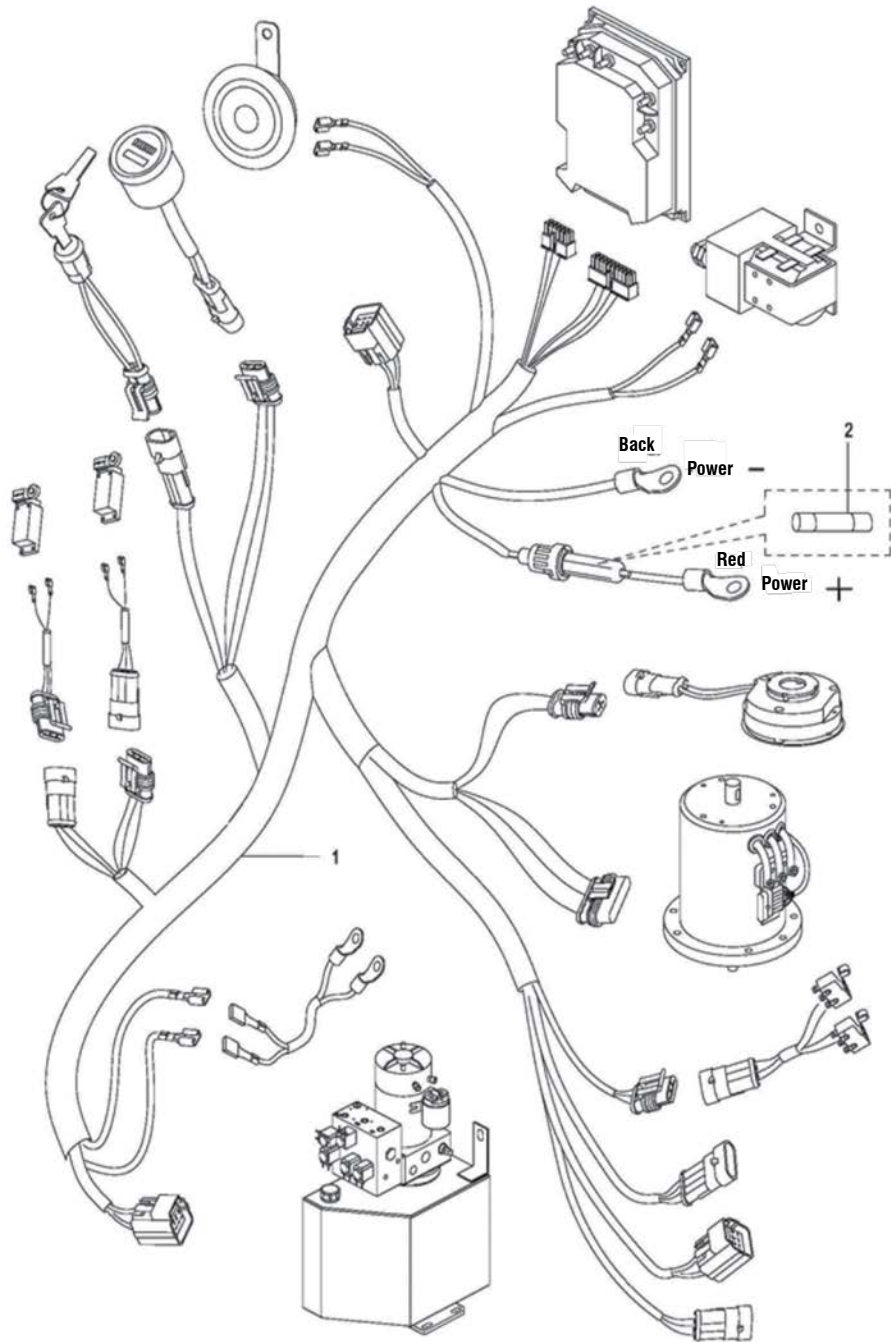



**WIRING HARNESS (USED WHEN SIDE SHIFT OPTION)**

INDEX NO.	PART NO.	PART NAME	NO. REQ.	NOTES
1	2130-520001-40	WIRING HARNESS	1	
1a	1220-520014-00	WIRE	1	Not Pictured: If changing from old hydraulic unit (used up to S2117012) to new Bucher unit (used from serial number S2117013) you have to add this wire.
2	1120-500010-00	FUSE 10A	1	

FIGURE 12-48 WIRING CABLES

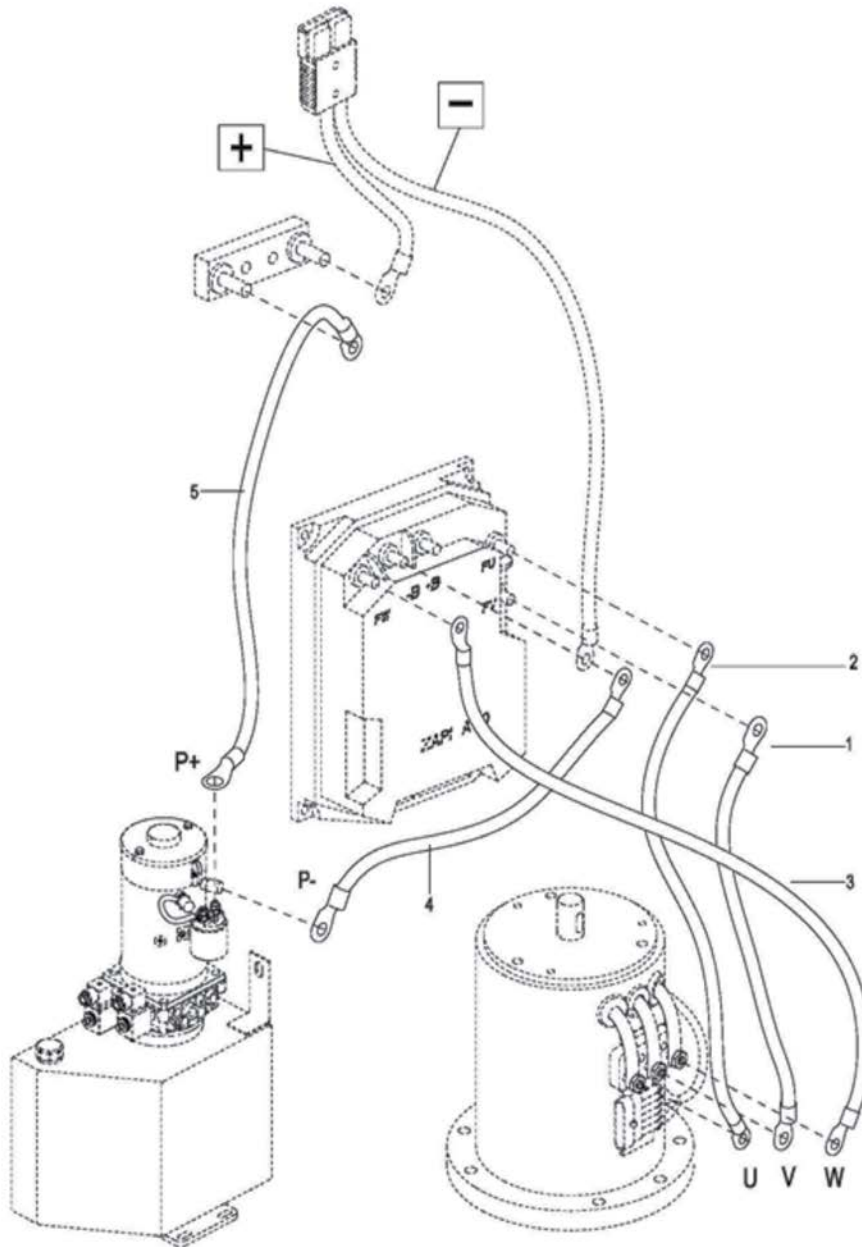

**WIRING CABLES**

INDEX NO.	PART NO.	PART NAME	NO. REQ.	NOTES
1	2130-530004-00	MOTOR LINE V	1	
2	2130-530005-00	MOTOR LINE U	1	
3	2130-530003-00	MOTOR LINE W	1	
4	2130-530007-00	PUMP POWER LINE -	1	
5	2130-530006-00	PUMP POWER LINE +	1	

FIGURE 12-49 BATTERY PACK (FACTORY INSTALLED) USED UP TO S2410120

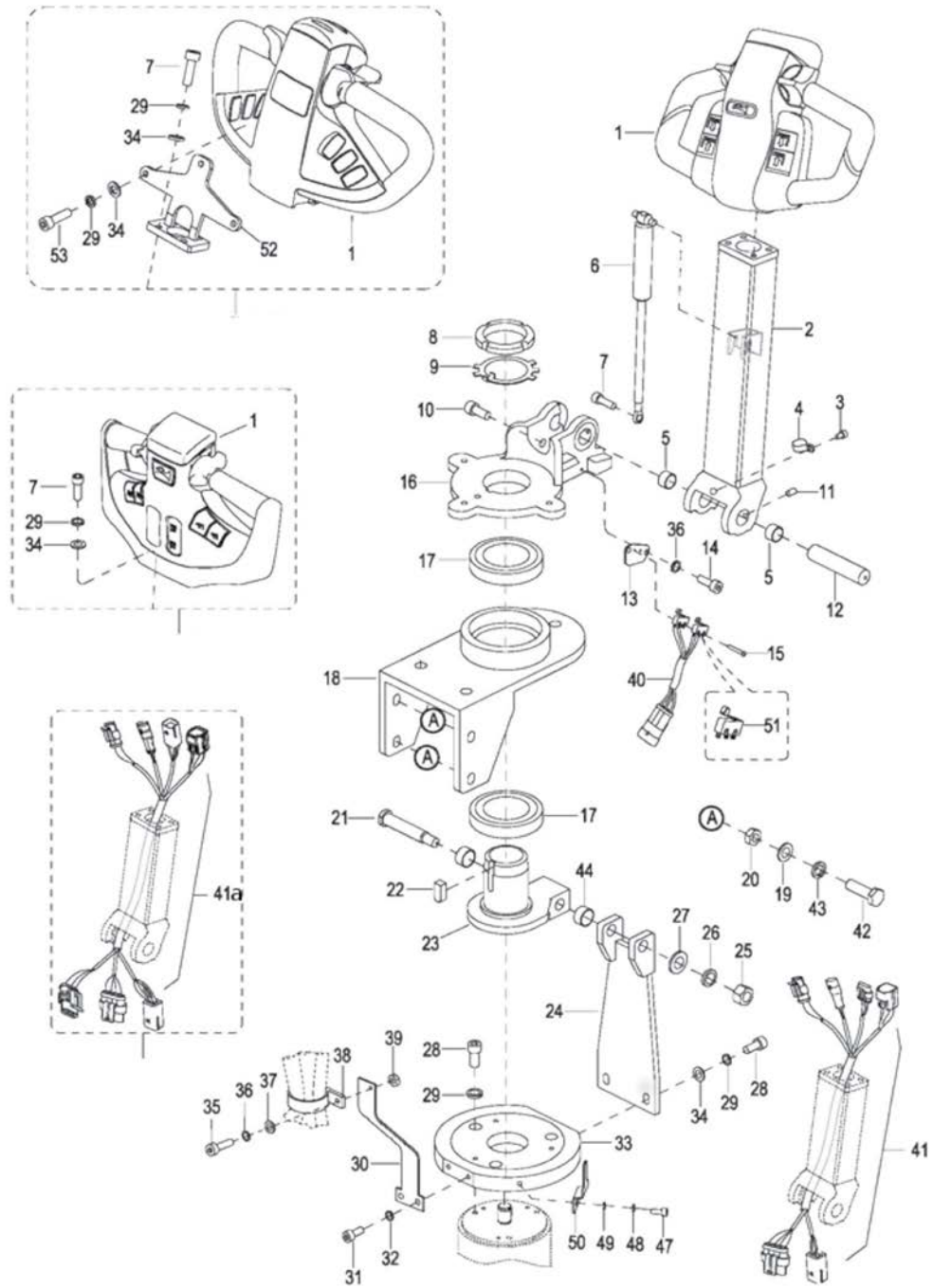

**BATTERY PACK (FACTORY INSTALLED) USED UP TO S2410120**

INDEX NO.	PART NO.	PART NAME	NO. REQ.	NOTES
1	0000-000055-00	SCREW M6 x 16	6	
2	0000-000056-00	LOCKWASHER Ø6	6	
3	0000-000023-00	FLATWASHER Ø6	4	
4	1145-550003-20	RUBBER CUSHION	4	
5	1145-550001-20	BLOCK	4	
6	0000-000119-00	SCREW M5 x 12	2	
7	0000-000206-00	LOCKWASHER Ø5	2	
8	1145-552000-2C	BATTERY COVER	1	
8a	1145-552000-2D	BATTERY COVER	1	Used from serial number S2310254 to S2410120
9	003232 BATTERY	BATTERY	4	
10	0000-000550-00	NUT M8	8	Customer has to check if cables are secured with bolts or nuts
10a	0000-000242-00	BOLT M8 x 16	8	
11	1145-553002-2L	M2 CABLE	1	
12	1145-553001-20	M1 CABLE	1	
13	1145-553003-2L	M3 CABLE	1	
14	1145-553100-20	CONNECTOR BATTERY ASSEMBLY	1	
15	0000-000102-00	SCREW M6 x 45	2	
16	2125-560001-00	PULLER HANDLE	1	
17	0000-000166-00	NUT M6	2	
18	1145-551000-2C	BATTERY FRAME	1	Used up to serial number S2310253
18a	1145-551000-2D	BATTERY FRAME	1	Used from serial number S2310254 to S2410120
19	1120-560000-00	CHARGER USA 110V	1	No longer available: If replacing old charger you have to order Kit part # 1145-EP25-20, Charger 1120-560000-00-01 and Cord 1120-560002-00
20	1145-550002-20	INSERTS	2	
21	1120-560001-00	CHARGER CABLE USA 110V	1	
22	0000-000851-00	SCREW M8 x 12	2	
23	0000-000390-00	FLATWASHER Ø5	2	
24	0000-000119-00	SCREW M5 x 12	2	Used up to serial number S2310253
24a	0000-000700-00	SCREW M8 x 16	2	Used from serial number S2310254 to S2410120
25	0000-000206-00	LOCKWASHER Ø5	2	Used up to serial number S2310253
25a	0000-000159-00	LOCKWASHER Ø8	2	Used from serial number S2310254 to S2410120
26	0000-000176-00	FLATWASHER Ø8	2	

FIGURE 12-50 BATTERY PACK (FACTORY INSTALLED) USED FROM SERIAL NUMBER S2410121 TO D24140007

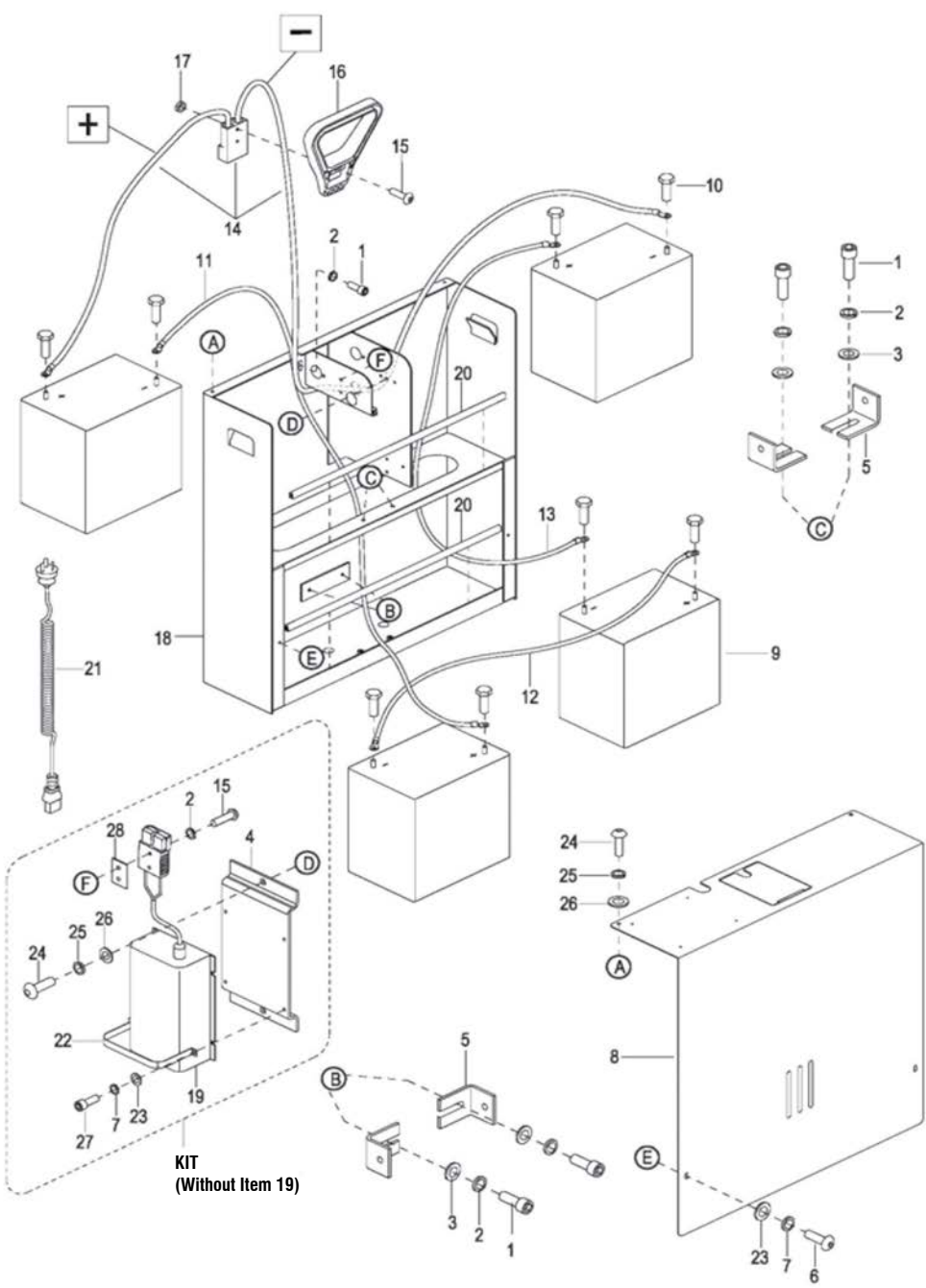

**BATTERY PACK (FACTORY INSTALLED) USED FROM SERIAL NUMBER S2410121 TO D24140007**

INDEX NO.	PART NO.	PART NAME	NO. REQ.	NOTES
1	0000-000055-00	SCREW M6 x 16	6	
2	0000-000056-00	LOCKWASHER Ø6	8	
3	0000-000380-00	FLATWASHER Ø6	4	
4	1145-550011-00	PLATE	1	
5	1145-550001-20	BLOCK	4	
6	0000-000119-00	SCREW M5 x 12	2	
7	0000-000206-00	LOCKWASHER Ø5	6	
8	1145-552000-2D	BATTERY COVER	1	
9	003232 BATTERY	BATTERY	4	
10	0000-000242-00	BOLT M8 x 16	8	
11	1145-553002-2L	M2 CABLE	1	
12	1145-553001-20	M1 CABLE	1	
13	1145-553003-2L	M3 CABLE	1	
14	1145-553100-20	BATTERY CONNECTOR ASSEMBLY	1	
15	0000-000498-00	SCREW M6 x 30	4	
16	12125-560001-00	PULLER HANDLE	1	
17	0000-000166-00	NUT M6	2	
18	1145-551000-2D	BATTERY FRAME	1	
19	1120-560000-00-01	CHARGER, 25A 110V	1	
20	1145-550002-20	INSERTION	2	
21	1120-560002-00	CHARGER CABLE 110V	1	
22	1115-500009-00	CHARGER HOOP	2	
23	0000-000390-00	FLATWASHER Ø5	6	
24	0000-000700-00	SCREW M8 x 16	4	
25	0000-000159-00	LOCKWASHER Ø8	4	
26	0000-000176-00	FLATWASHER Ø8	4	
27	0000-000117-00	SCREW M5 x 10	4	
2	1120-112008-00	PLATE 1	1	
KIT	1145-EP25-20	KIT FOR CHARGER INSTALLATION	1	Charger pos. # 19 is not included

FIGURE 12-51 BATTERY PACK (FACTORY INSTALLED) USED FROM SERIAL NUMBER D24140008

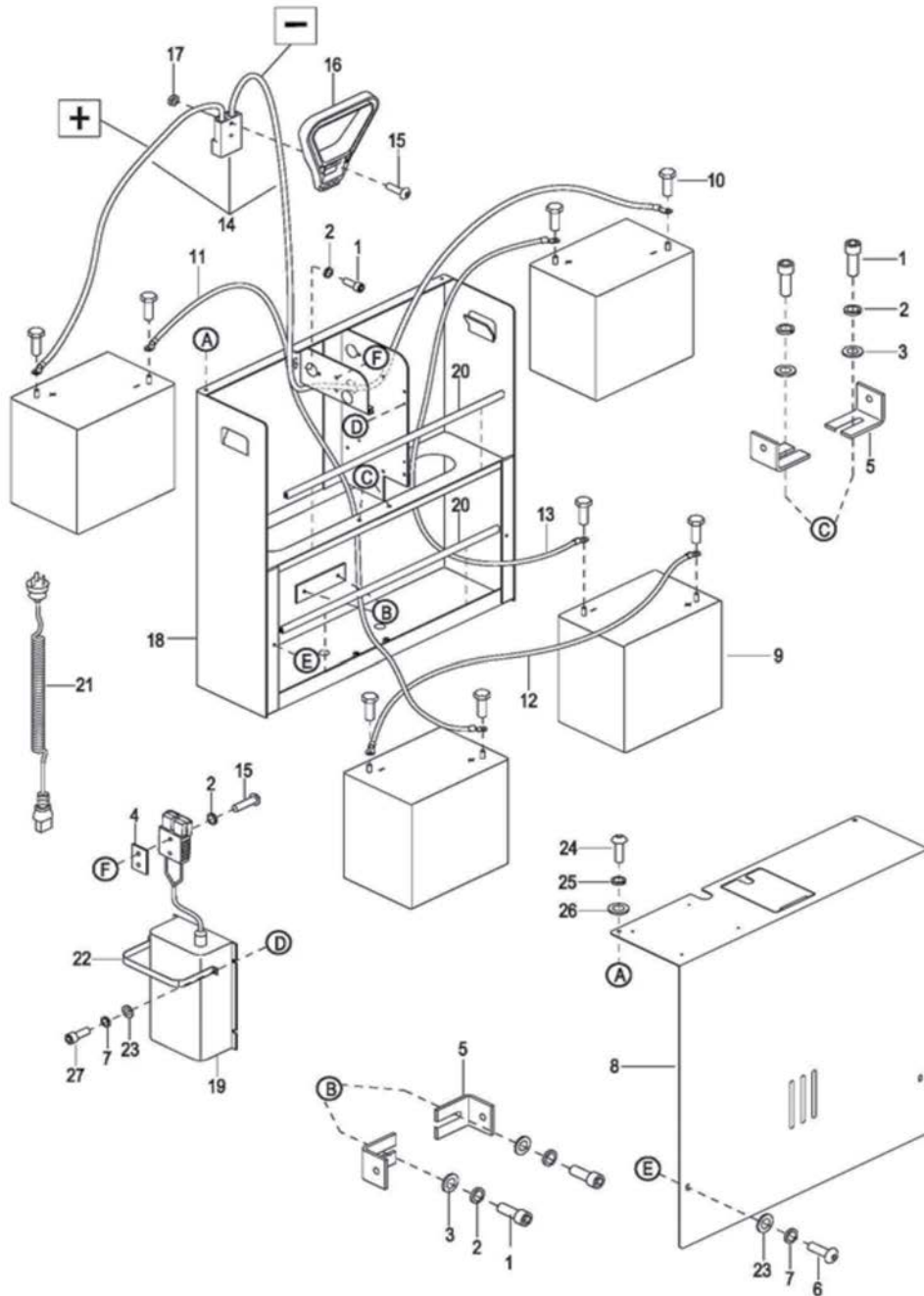



**BATTERY PACK (FACTORY INSTALLED) USED FROM SERIAL NUMBER D24140008**

INDEX NO.	PART NO.	PART NAME	NO. REQ.	NOTES
1	0000-000055-00	SCREW M6 x 16	6	
2	0000-000056-00	LOCKWASHER Ø6	8	
3	0000-000380-00	FLATWASHER Ø6	4	
4	1120-112008-00	PLATE	1	
5	1145-550001-20	BLOCK	4	
6	0000-000119-00	SCREW M5 x 12	2	
7	0000-000206-00	LOCKWASHER Ø5	6	
8	1145-552000-2D	BATTERY COVER	1	
9	003232 BATTERY	BATTERY	4	
10	0000-000242-00	BOLT M8 x 16	8	
11	1145-553002-2L	M2 CABLE	1	
12	1145-553001-20	M1 CABLE	1	
13	1145-553003-2L	M3 CABLE	1	
14	1145-553100-20	BATTERY CONNECTOR ASSEMBLY	1	
15	0000-000498-00	SCREW M6 x 30	4	
16	2125-560001-00	PULLER HANDLE	1	
17	0000-000166-00	NUT M6	2	
18	1145-551000-2E	BATTERY FRAME	1	
19	1120-560000-00-01	CHARGER, 25A, 110V	1	
20	1145-550002-20	INSERTION	2	
21	1120-560002-00	CHARGER CABLE USA	1	
22	1115-500009-00	CHARGER HOOP	2	
23	0000-000390-00	FLATWASHER Ø5	6	
24	0000-000700-00	SCREW M8 x 16	4	
25	0000-000159-00	LOCKWASHER Ø8	4	
26	0000-000176-00	FLATWASHER Ø8	4	
27	0000-000117-00	SCREW M5 x 10	4	

**NOTES**

**NOTES**

**BLUE GIANT**<sup>®</sup>  
BLUE GIANT EQUIPMENT CORPORATION

**Corporate** 410 Admiral Blvd  
Mississauga ON L5T 2N6  
t 905.457.3900 f 905.457.2313

**USA** 6350 Burnt Poplar Rd  
Greensboro, NC 27409  
[www.bluegiant.com](http://www.bluegiant.com)