

# OWNER'S MANUAL

## MECHANICAL DOCK LEVELER



ACTUAL PRODUCT MAY NOT APPEAR EXACTLY AS SHOWN



### WARNING

Do not operate or service this product unless you have read and fully understand the entire contents of this manual. Failure to do so may result in property damage, bodily injury or death.

**BLUE GIANT**<sup>®</sup>

**TABLE OF CONTENTS**

<b>1.0</b>	<b>ABOUT THE MECHANICAL DOCK LEVELER</b>	<b>4</b>
1.1	OWNER’S PURCHASE RECORD	4
<b>2.0</b>	<b>INTRODUCTION</b>	<b>5</b>
2.1	WARRANTY INFORMATION	5
2.2	EXCLUSION OF LIABILITY	5
2.3	MANUFACTURER’S NOTE	5
2.4	OWNER’S RESPONSIBILITY	6
<b>3.0</b>	<b>OWNER’S MANUAL SAFETY MESSAGE COLOR IDENTIFICATION</b>	<b>7</b>
3.1	OPERATIONAL SAFETY WARNINGS	7
<b>4.0</b>	<b>LOCKOUT / TAGOUT PROCEDURE AND RULES</b>	<b>8</b>
<b>5.0</b>	<b>DOCK STRUT SET-UP</b>	<b>9</b>
5.1	ENGAGING THE DOCK STRUT	9
5.2	DISENGAGING THE DOCK STRUT	9
<b>6.0</b>	<b>MAINTENANCE</b>	<b>10</b>
6.1	PLANNED MAINTENANCE	10
6.2	OPERATOR DAILY INSPECTION	10
6.3	ROUTINE SERVICING AND MAINTENANCE	10
6.4	PLANNED MAINTENANCE INTERVALS	10
6.5	MAINTENANCE SEQUENCE	10
6.6	DAILY MAINTENANCE PROCEDURES (DMP) CHECKLIST - MECHANICAL DOCK LEVELER	11
<b>7.0</b>	<b>OPERATING INSTRUCTIONS</b>	<b>12</b>
7.1	FUNCTIONAL DESCRIPTION	12
7.2	DEPLOYING THE DOCK LEVELER	13
7.3	STORING THE DOCK LEVELER	13
7.4	BELOW LEVEL / END LOADING	14
7.5	OVERRIDING THE FALL-SAFE OPTION	14
<b>8.0</b>	<b>RECOMMENDED SPARE PARTS - MECHANICAL DOCK LEVELER</b>	<b>15</b>
8.1	RECOMMENDED SPARE PARTS - RATCHET HOLD-DOWN ASSEMBLY	15
<b>9.0</b>	<b>DECAL IDENTIFICATION AND LOCATION</b>	<b>16</b>
<b>10.0</b>	<b>EQUIPMENT COMPONENT ILLUSTRATIONS</b>	<b>17</b>
10.1	COMPONENTS AS SHIPPED CHECKLIST	17
10.2	MECHANICAL ASSEMBLY - MECHANICAL DOCK LEVELER	18
10.3	MECHANICAL ASSEMBLY - MECHANICAL DOCK LEVELER - CONT'D	19
10.4	DECK	20
10.5	LIP	20
10.6	LIP SHAFT	20
10.7	FRAME	21
10.8	STANDARD PIT DIMENSIONS	21

**TABLE OF CONTENTS CONT'D.**

10.9 STANDARD PIT DIMENSIONS	22
<b>11.0 RATCHET HOLD-DOWN ASSEMBLY</b>	<b>23</b>
<b>12.0 TOE GUARDS</b>	<b>24</b>
<b>13.0 DOCK LEVELER TROUBLESHOOTING</b>	<b>25</b>
13.1 DOCK LEVELER TROUBLESHOOTING - CONT'D	21
<b>14.0 OPTIONAL TLC24 CONTROLS</b>	<b>26</b>
<b>15.0 OPTIONAL EXTERIOR TRAFFIC LIGHT / MIRROR IMAGE SIGN</b>	<b>28</b>
15.1 OPTIONAL HOME INTERLOCK SENSOR	28
<b>16.0 WIRING DIAGRAMS</b>	<b>28</b>
16.1 TLC24-A 115V AND 230V SINGLE PHASE (AUTOMATIC)	29
16.2 TLC24-M 115V AND 230V SINGLE PHASE (MANUAL)	30

### 1.0 ABOUT THE MECHANICAL DOCK LEVELER

The Blue Giant Mechanical Dock Leveler is a high performance yet easy to operate system. No manual lifting is involved: simply pull the hold-down release ring (located at the rear of the leveler) to activate the ratchet hold-down system and the deck will move upward, propelled by heavy-duty lift springs. Walk the dock down onto the truck bed, and begin loading / unloading.

The deck is held in place by a precision-milled steel ratchet hold-down system that provides superior locking capabilities.

The lip actuator allows the lip to move smoothly out to the locked position as the deck rises. When the truck departs, the lip will automatically release and lower.

High tensile enhanced J-Beams are welded at dynamic impact points on the underside of the deck, preventing "dishing" and providing structural integrity.

### 1.1 OWNER'S PURCHASE RECORD

**OWNER'S PURCHASE RECORD**  
Please record information for future inquiries and to validate warranty. (See Section 2.1 "Warranty Information" for warranty validation)

<b>Dealer:</b>	<b>Date in Service:</b>
	<b>Number of Units:</b>
<b>Serial Number:</b>	<b>Door #:</b>
<b>Serial Number:</b>	<b>Door #:</b>
<b>Serial Number:</b>	<b>Door #:</b>
<b>Serial Number:</b>	<b>Door #:</b>
<b>Serial Number:</b>	<b>Door #:</b>
<b>Serial Number:</b>	<b>Door #:</b>
<b>Serial Number:</b>	<b>Door #:</b>
<b>Serial Number:</b>	<b>Door #:</b>
<b>Serial Number:</b>	<b>Door #:</b>
<b>Serial Number:</b>	<b>Door #:</b>

The manufacturer offers a full line of dock levelers, dock safety equipment, accessories, ergonomic and scissor lift equipment, seals and shelters, and industrial trucks. Concurrent with a continuing product improvement program, specifications are subject to change without notice (See Section 2.2 "Exclusion of Liability" of this manual). Please contact the manufacturer for latest information. Some features illustrated may be optional in certain market areas.

<b>NOTICE</b>
See Section 9.0 "Decal Identification and Location" item #5 for serial number location.

## 2.0 INTRODUCTION

The following is a quick reference to important procedures that must be followed while using the Loading Dock Equipment. It is not intended to cover, or suggest that it does cover, all procedures necessary to ensure safe operation. All operators should be aware of and abide by all workplace safety regulations applicable to the operation of the Loading Dock. These laws and regulations include but are not limited to:

- The Occupational Safety and Health Act
- Canada Occupational Health and Safety Regulations
- Occupational Safety and Health Acts for Individual States (USA)

For additional information on these regulations as well as industry standards that may apply to this product, please contact:



American National Standards Institute (ANSI)  
1430 Broadway  
New York, NY 10018  
Telephone: 212.642.4900  
www.ansi.org

Also a member of:



Loading Dock Equipment Manufacturers  
A Product Section of Material Handling Industry of America  
A Division of Material Handling Industry  
8720 Red Oak Blvd, Suite 201  
Charlotte, NC, 28217-3992  
Telephone: 704.676.1190  
www.mhi.org/lodem

## 2.1 WARRANTY INFORMATION

Thank you for purchasing Blue Giant products. We appreciate your business, and are confident that our product will serve you for many years to come. In the event that you experience a problem with our product, our Warranty Center is here to support the Blue Giant Product(s) that you have purchased.

To validate warranty on recently purchased equipment, please complete and submit your information with our on-line Warranty Registration at [www.bluegiant.com](http://www.bluegiant.com).

For more information about Blue Giant Warranty Support, please contact your local Blue Giant Equipment dealer, representative or authorized partner near you. You may also visit [www.bluegiant.com](http://www.bluegiant.com) or phone 1.905.457.3900.

### DEALER INFORMATION

Name:

Contact:

Telephone:

\* **NOTE** that failure to validate warranty at the time of receipt can seriously effect the outcome of any claim.

## 2.2 EXCLUSION OF LIABILITY

The manufacturer assumes no liability for damage or injury to persons or property which occur as a result of defects or faults in or incorrect use of the Loading Dock Equipment. The manufacturer also assumes no liability for lost profits, operating downtimes, or similar indirect losses incurred by the purchaser. Injury to third parties, irrespective of its nature, is not subject to compensation.

The manufacturer reserves the right to make changes at any time to the modules, components, and accessories, concurrent with its continuing product improvements and development program. Specifications, operating instructions, and illustrations included in this manual are subject to change without notice. Please contact manufacturer for the latest information.

## 2.3 MANUFACTURER'S NOTE

The dock equipment has been carefully inspected and tested at the manufacturer's plant prior to shipment, but should be checked upon receipt for transport damage. Any observed transport damage is to be listed on the signed copy of the freight document. Notify the freight forwarder of any damage **WITHIN 48 HOURS**.

## 2.4 OWNER'S RESPONSIBILITY

1. The owner should recognize the inherent danger of the interface between the dock and the freight carrier. The owner should, therefore, train and instruct operators in the safe use of the dock equipment and accessories in accordance with the manufacturer's recommendations.
2. The owner should thoroughly familiarize themselves with the following procedures and specifications, and request immediate replacement of all manufacturer-supplied documents that are missing, damaged, or otherwise illegible. Below is a list of Best Practices for dock equipment usage and maintenance.
  - Commissioning instructions
  - Operating instructions
  - Daily maintenance procedures checklist
  - Inspections procedures
  - Recommended spare parts lists

Upon receipt of any newly purchased dock equipment, the owner shall verify the presence of owner's manuals, operating placards, and any other documentation necessary for training dock personnel how to use the equipment safely and effectively.
3. All Blue Giant dock equipment should undergo regularly scheduled planned maintenance. Maintenance requirements will vary according to usage frequency and application, so the owner shall consult with their authorized Blue Giant distributor for schedule recommendation. Written records of the performance of these procedures should be kept as per warranty requirements.
4. Dock equipment that is structurally damaged, experiencing performance irregularities, or has been potentially compromised shall be removed from service until a trained and authorized manufacturer's representative can conduct an inspection and perform any necessary repairs.
5. As with any piece of machinery, dock equipment requires routine maintenance, lubrication, and adjustments. Recommended procedures are itemized in the Planned Maintenance Program (PMP) checklist included in installation and technical manuals. It is recommended that for anything other than the basic maintenance procedures outlined in this manual, you contact your local Blue Giant representative.
6. The owner shall ensure that all name plates and safety labels are in place and legible, and that the appropriate manuals are provided to authorized users. Replacement name plates, safety labels, and manuals are available through the Blue Giant Aftermarket Department. See "Decal Identification and Location" section in this manual for more information.
7. The owner or a trained and authorized representative shall verify that all freight carrier brakes have been applied and a vehicle restraint and/or wheel chocks properly engaged before cross-docking procedures begin. For safety reasons trailers must be held securely in place to avoid accidental separation from the loading dock.
8. Unless specifically agreed to in writing by Blue Giant Equipment Corporation at the time of order (and prior to manufacture), all Blue Giant Dock equipment is sold as a complete offering and must not be altered or added to in any manner (which includes configuration and function) without written permission from an authorized manufacturer's representative. These changes shall also satisfy all safety recommendations of the original equipment manufacturer for the particular application of the dock equipment.
9. If, at the request of the owner, Blue Giant does not supply all or some of the dock equipment power unit and/or control panel components, the owner shall assume responsibility for any and all operational and safety issues associated with the resulting configuration.
10. The owner must adhere to the load classification information provided on the product serial plate. Failure to do so will void product warranty.

**3.0 OWNER'S MANUAL SAFETY MESSAGE COLOR IDENTIFICATION**

This manual includes color-coded safety messages that clarify instructions and specify areas where potential hazard exists. To prevent the possibility of equipment damage and serious injury or death, please observe strictly the instructions and warnings contained in the messages. If warning decals become damaged or missing, replace them immediately. Avoid accidents by recognizing dangerous procedures or situations before they occur.

 **DANGER**

Serious injury or death will likely occur if the instructions are not followed.

 **NOTICE**

Procedures marked important must be followed in order to prevent damage to machinery.

 **WARNING**

Serious injury or death may occur if the instructions are not followed.

 **CAUTION**

Instructions marked caution concern safe operating procedure. Failure to comply may result in personal injury.

**3.1 OPERATIONAL SAFETY WARNINGS**

 **DANGER**

1. Do not enter the pit area below the dock leveler.
2. BEFORE BEGINNING ANY SERVICE PROCEDURES:
  - Follow all lockout / tagout procedures.
3. Never operate a broken or damaged dock leveler. Have repairs done immediately by a qualified service technician.
4. Always secure and center loads on the forklifts. Loose or unbalanced loads are dangerous.

 **NOTICE**

1. Do not ground welding equipment to any electrical components.
2. Do not attach welder as ground to leveler platform when welding on base frame assembly. Attach welder ground to base frame assembly only.
3. Always keep the work area clean and free of litter.
4. Always clean all side openings of dirt and debris.
5. Always clean all dirt and debris from the lip hinge.
6. Always clean up dry and liquid spills immediately after they occur.
7. Always maintain proper lighting in the work area.
8. If a procedure is not clearly defined in this manual, contact your authorized Service Representative.

 **WARNING**

1. The upper hinge point is a hazardous pinch point. Do not use fingers or hands to remove foreign materials.
2. Post safety warnings and barricade working area at dock level and at ground level to prevent unauthorized use of the leveler during maintenance/service.
3. Never leave the dock leveler unattended in the raised position.
4. Always make sure that the lip is seated inside the night lock after putting the dock in the parked position.
5. Never leave loads sitting on the dock leveler.
6. Do not attempt to raise the dock leveler if someone is standing on it.
7. Do not use the dock leveler if the lip's full width is not fully supported by the vehicle load bed.
8. Do not operate the dock leveler beyond its rated capacity.
9. Do not drive or walk onto the truck until it is parked against the dock bumpers and the wheels are chocked, or the vehicle restraint has been fully engaged.
10. Never attempt to lift or hold the lip out by hand. Serious personal injury could occur.
11. Never remove the wheel chocks until loading/ unloading is finished and the truck driver has been given permission to depart.

 **CAUTION**

1. Only trained personnel should operate or service this equipment.
2. Do not operate the dock equipment until the transport vehicle is parked against the dock bumpers.
3. Always park the dock equipment after use.
4. Conduct routine inspections and maintenance. Failure to do so could cause equipment damage and or personal injury.
5. Always call your authorized service representative or manufacturer immediately if a malfunction occurs.

#### 4.0 LOCKOUT / TAGOUT PROCEDURE AND RULES

In accordance with the rules and regulations of the Occupational Safety and Health Administration (OSHA), all affected employees must be notified that the machine or equipment will be shut down and locked out to perform repair or maintenance work. The work area must be checked to ensure that all personnel have been removed or safely repositioned. The machine or equipment power supply shall be locked in the OFF/OPEN position or Mechanically disconnected from the energy source. Blue Giant strongly recommends that only OSHA-approved lockout devices and procedures be utilized.

The energy isolating device must bear a prominent warning tag indicating that work is being done on the equipment and the name of the authorized employee responsible for the lockout. It is mandatory that tagout notices not be susceptible to deterioration or illegibility due to weather conditions or exposure to chemicals and moisture.

 **WARNING**

Always lockout and tagout any power source before performing any work on any electrical devices or electrical controls according to OSHA regulations and approved local electrical codes.

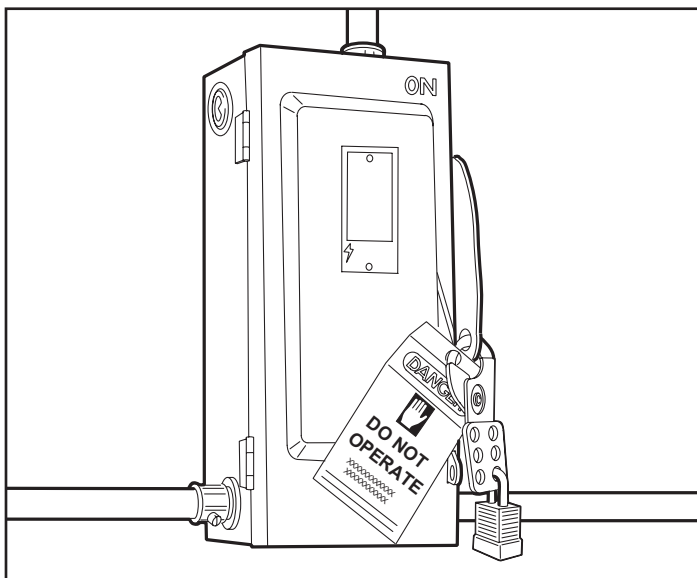

Approved way to lockout / tagout.



**5.0 DOCK STRUT SET-UP**

**⚠ DANGER**

Failure to properly secure the dock leveler deck prior to working underneath it may result in property damage, bodily injury, or death. Engage the Dock Strut AND Service Stand first. If the device cannot be successfully engaged, contact your authorized service representative.

**⚠ WARNING**

Post safety warnings and barricade work area at dock and ground level. Notify all affected personnel that work is being performed on the unit and follow proper lock-out procedure. Ensure that power to the unit has been completely cut off and cannot be turned back on accidentally.

**5.1 ENGAGING THE DOCK STRUT**

**⚠ WARNING**

Head protection and other applicable PPE is recommended when working under or around the raised deck.

**⚠ WARNING**

Install dock strut and secondary service stand only when the unit is fully raised and deployed.

**⚠ CAUTION**

Use of a service stand and hard hat while performing this step is required.

**⚠ WARNING**

Use of a service stand (Part #796-710) in conjunction with the dock strut is required when working under the leveler.

This dock is equipped with a one piece dock strut that must be used, in conjunction with a service stand, during under-dock inspections or repairs / maintenance. The V-shape ensures safe headboard and lip support.

To apply the dock strut, one person raises the deck while another puts the strut in place.

It is recommended that a retrieval tool be used when retrieving the dock strut from its storage position beneath the dock.

**NOTE:** It is recommended that this step be performed with assistance.

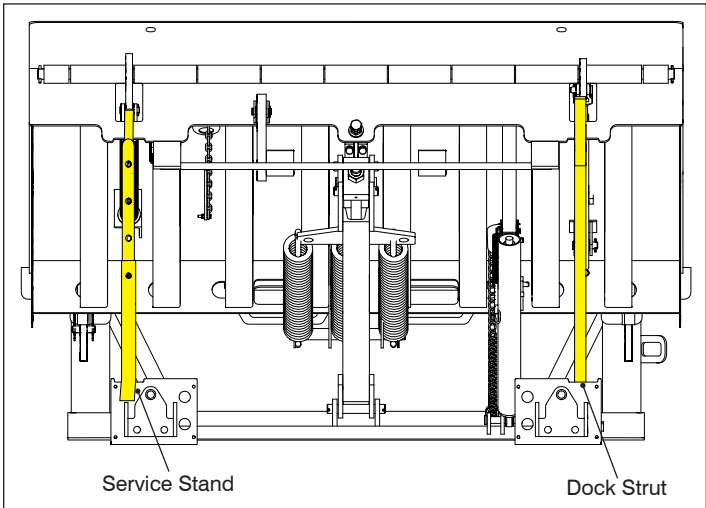

Engaged Service Stand (part # 26-011895) and Dock Strut (part # 796-710).

**5.2 DISENGAGING THE DOCK STRUT**

**⚠ CAUTION**

Remove the service stand only AFTER disengaging the dock strut (or equivalent)

After verifying that it is safe to disengage the dock strut, pull upwards on the dock strut and lower gently into the storage position.

Do not stand in the pathway of the dock leveler during the disengagement process in case the dock falls unexpectedly.

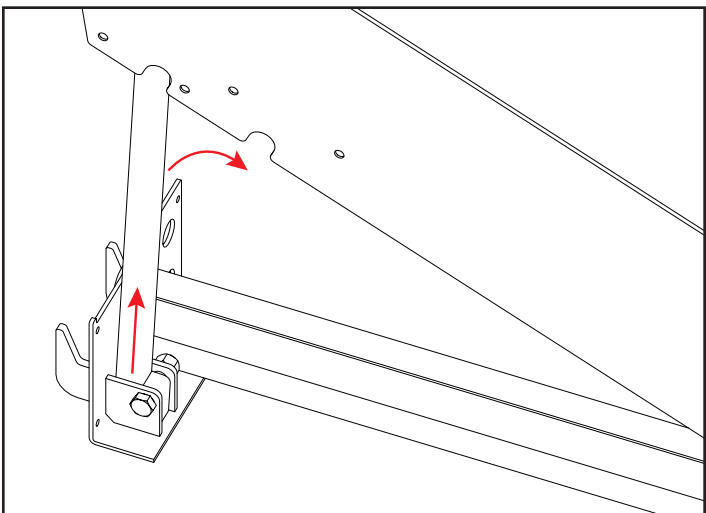

## 6.0 MAINTENANCE



### WARNING

Do not operate and/or service this dock leveler until you have read and understood all of the safety information and instructions contained herein and on the dock leveler.

Do not work under or around dock leveler without first placing adequate barriers to positively prevent vehicle traffic from entering the work area.

Follow proper lock-out/tag-out procedures.

Keep hands and feet clear of dock leveler pinch points and wear appropriate safety attire – safety glasses, gloves and work boots.

The maintenance strut and safety stand must be in place before commencing maintenance procedures.

### 6.1 PLANNED MAINTENANCE PROGRAM (PMP)

In addition to the Daily Maintenance Procedures (DMP), the manufacturer recommends (and local government regulations may require) that a Planned Maintenance Program (PMP) and safety inspection program be performed by a trained and authorized service technician on a regular basis to ensure the equipment is in safe operating condition. The PMP will provide an opportunity to make a thorough inspection of the safety and operating condition of the dock leveler. Necessary adjustments and repairs can be done during the PMP, which will increase the life of components and reduce unscheduled downtime.

Recommended procedures for a periodic planned maintenance program that covers inspections, operational checks, cleaning, lubrication, and minor adjustments are outlined in the Installation and Technical manual for this product.

An authorized dealer or distributor is prepared to assist with a planned maintenance program by offering trained service personnel with expertise in dock leveler maintenance requirements.

### 6.2 OPERATOR DAILY INSPECTION

The dock leveler should always be examined by the operator **PRIOR TO ANY USE** to verify that it is safe to operate.

The manufacturer recommends making multiple photocopies of the DMP Checklist (See Section 6.6). The operator should fill out this form to keep a daily record of operation and maintenance issues.

### 6.3 ROUTINE SERVICING AND MAINTENANCE

Regular maintenance and care of the dock leveler is very important for cost and operation efficiency and more importantly; operator safety. A faulty dock leveler is a potential source of danger to the operator, and to other personnel working near it. As with all quality equipment, keep the dock leveler in good operating condition by following the recommended schedule of maintenance. Failure to properly maintain or operate the dock leveler within its rated load classification can void the manufacturer warranty.

### 6.4 PLANNED MAINTENANCE PROGRAM INTERVALS

Arrange for a qualified dock leveler repair technician to perform regularly scheduled planned maintenance on your dock leveler every three months for single shift operations or monthly for multi-shift operations. Call your authorized manufacturer / dealer for further details.

### 6.5 MAINTENANCE SEQUENCE

1. Safety visual inspection.
2. Cleaning, including pit area.
3. Visual inspection of all components.
4. Lubrication, as required (by a trained service technician only).
5. Test operate all functions.
6. Adjustments, if required (by a trained service technician only).
7. Check for missing or damaged dock bumpers.
8. Record inspection details and findings for owners' files.

**6.6 DAILY MAINTENANCE PROCEDURES (DMP) CHECKLIST - MECHANICAL DOCK LEVELER**

**INSPECTED BY:** \_\_\_\_\_ **DATE:** \_\_\_\_\_

**SERIAL #:** \_\_\_\_\_ **DOOR #:** \_\_\_\_\_

Forward this checklist to the person responsible for dock equipment maintenance. See Section 1.1 "Owner's Purchase Record" for Date in Service.

**INSTRUCTIONS:** Indicate "OK for USE" with a check mark ✓ in the appropriate box of each inspection point. Indicate "NOT OK for USE" with an x in the appropriate box of each inspection point.

**EVERY DAY (MAY BE PERFORMED BY OWNER OR ATTENDANT):**

- Remove any debris that may have accumulated around the dock equipment
- Verify complication-free operation of the dock equipment and the interior and exterior lights system (if installed)
- Verify that outside signage is present and legible (if equipped)
- Remove any potential trip hazards from around the dock area
- Verify that dock bumpers/risers/extensions are in working condition (if equipped)
- Check curb angles for irregularities (e.g. concrete cracks)
- Verify that the overhead door is functioning correctly, if equipped.
- Verify that instructional caution and danger labels are present and legible on the product. Replace if necessary
- Verify that vehicle restraint or wheel chocks at minimum are present and in working condition

**PHOTOCOPY THIS CHECKLIST AND FILL OUT REGULARLY FOR YOUR RECORDS.**

**Explain faults briefly in the space provided below:**

---



---



---



---



---

<b>DANGER</b>
When repairing or conducting maintenance procedures on electrical components, perform lockout / tagout steps according to OSHA regulations and approved electrical codes.

<b>DANGER</b>
Prior to installation, place adequate barriers to prevent unauthorized personnel and vehicle traffic from entering the work area.

<b>WARNING</b>
All repairs and maintenance work are to be conducted by trained and authorized personnel ONLY.

**7.0 OPERATING INSTRUCTIONS**

WARNING

Do not operate this leveler unless you have been trained and authorized to do so, and have read and understood all of the safety information and instructions contained herein.

Do not operate the dock leveler beyond its rated capacity.

Do not operate this leveler until you have checked its condition. Report the need for repairs to your supervisor immediately and do not operate the unit until repairs are made. Neglect may cause a minor repair to become a major service problem and cause the leveler to become unsafe.

Never try to lift or move any part of the dock leveler manually.

Do not drive on the leveler unless the lip is securely on the truck bed and has a minimum of 4" (102mm) overlap on its surface.

Do not exceed 4 mph when driving over the dock leveler.

Do not drive over edges of the leveler and / or dock bumper blocks (bumpers blocks are not structural).

Confirm brakes have been set and air has been removed from the air-ride suspension (if applicable).

**OPERATING INSTRUCTIONS**  
Only for Mechanical Dock Levelers

**A**

**DEPLOYING THE DOCK LEVELER**

1. Raise the leveler by pulling up the hold-down release ring at the rear of the deck. As the deck rises, the lip will swing up and extend. Let go of the release ring once the deck reaches full height.
2. Walk-down the deck until the lip has lowered onto the vehicle load bed. Do not step on the lip.

**B**

**STORING THE DOCK LEVELER**

1. When loading / unloading procedures have been completed, pull on the hold-down release ring until the deck raises high enough for the lip to clear the load bed. Let go of the release ring.
2. Walk down the deck once the lip has fully retracted. Do not step on the lip. Ensure that the lip is parked inside the lip keeper.

**C**

**BELOW LEVEL / END LOADING**

1. Raise the leveler by pulling up the hold-down release ring at the rear of the deck. As the deck rises, the lip will swing up and extend. Let go of the release ring once the deck reaches full height.
2. Approach the front of the deck and pull the below level lip deployment chain until the lip extends enough to position it between the face of the leveler and the trailer. Do not step on the lip.

⚠ DANGER

1. Only trained and authorized personnel may operate this dock leveler.
2. Read, understand, and follow the instructions on this document.
3. Prior to using the dock leveler:
  - Ensure that the dock leveler is free and clear of all debris, snow and ice.
  - Ensure that all personnel near the dock leveler are aware that it is being operated.
  - Operate the dock leveler through one complete cycle to confirm that it is functioning properly. If the dock leveler is equipped with a communications package, confirm that the lights are working as required.
  - Inspect unit for signs of structural damage or mechanical malfunction. If damage is observed or the restraint fails to operate properly, remove it from service and notify maintenance personnel immediately.
4. When using the dock leveler:
  - Confirm that the transport vehicle has been properly restrained.
  - Keep hands and feet clear of pinch points.
  - If the dock leveler is equipped with a light communication package, load and unload on green only.
  - Do not exceed the rated capacity as indicated on the serial plate.
  - Do not leave equipment or material unattended on the dock leveler.
  - Keep a safe distance from both edges.
  - If dock leveler fails to operate as outlined in the accompanying manual's operating instructions, refer to the Troubleshooting section.
5. If service or maintenance is required:
  - Only authorized service personnel shall maintain or service the unit.

APPLIES TO ALL DOCK LEVELERS

BLUE GIANT, www.BlueGiant.com 038-1027E

Mechanical Dock Leveler operation placard—part # 038-1027E.

**7.1 FUNCTIONAL DESCRIPTION**

The Mechanical Dock Leveler serves as a bridge between a loading dock floor and a truck bed. The upper deck plate of the leveler, complete with a hinged, vertically hanging lip, is in a shallow pit at the edge of the dock, flush with the edge of the dock and the floor surface.

After the door has been opened, the rear of the truck is parked and restrained in place against the outer wall of the loading dock, in working alignment with the dock leveler. To activate the dock leveler, firmly pull the hold-down release ring located at the left rear corner of the deck, holding it until the lift springs completely raise the deck. The lip will automatically extend and lock as the deck reaches the fully raised position.

The dock attendant walks up the slope of the deck to lower it. The extended lip makes firm contact with the truck bed. At this point, the bridge is formed.

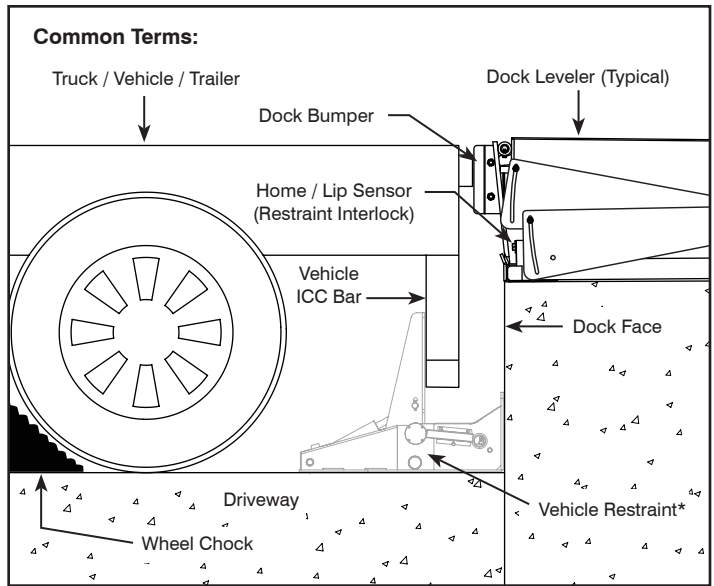

\* For Reference

## STANDARD OPERATION PROCEDURES



### WARNING

Walk carefully when performing the walk-down procedure, taking special precautions if the deck is wet or slippery.

### 7.2 DEPLOYING THE DOCK LEVELER

1. Raise the dock leveler by firmly pulling up the hold-down release ring located at the rear of the deck. As the lip rises, it will automatically swing up and extend. Let go of the release ring once the deck reaches full height.
2. Walk the leveler down until the lip is resting on the vehicle load bed. If the leveler does not fully lower during the walk-down process, do not attempt to complete the process by jumping on the deck or stepping on the lip. The minimum weight required to successfully walk-down the deck is 160 lb (73 kg).

While in use, the deck will raise and lower to match the vertical motion of the truck.

**NOTE:** Letting go of the hold-down release ring at any time will stop the upward travel of the deck.

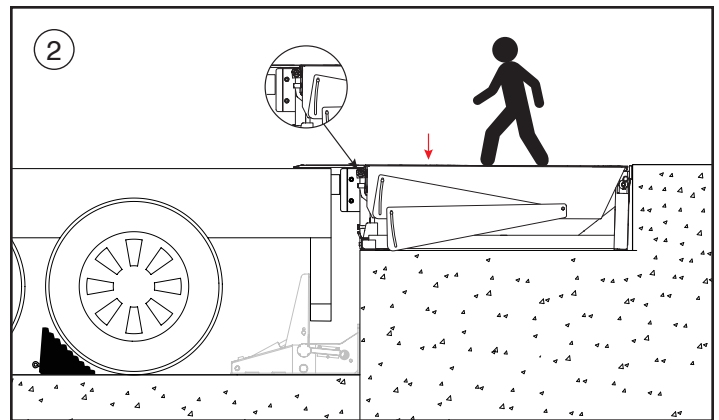
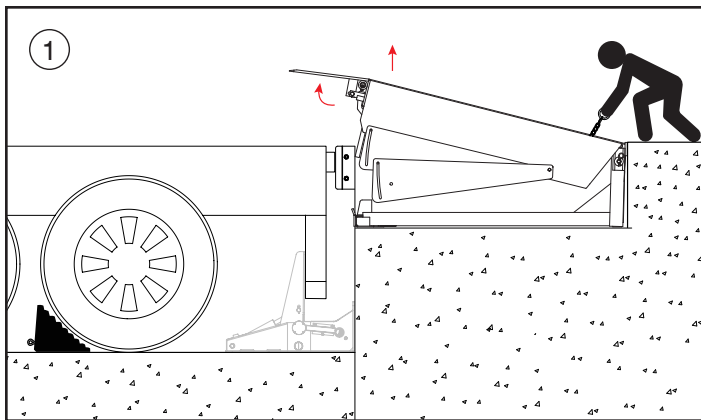

### 7.3 STORING THE DOCK LEVELER

1. When loading / unloading operations have been completed, pull on the hold-down release ring until the deck raises high enough for the lip to clear the load bed while moving in a downward arc.
2. Let go of the release ring and walk down the deck once the lip has completely retracted. If the leveler does not fully lower during the walk-down process, do not attempt to complete the process by jumping on the deck or stepping on the lip. The minimum weight required to successfully walk-down the deck is 160 lb (73 kg). Ensure that the lip is parked inside the lip keepers.

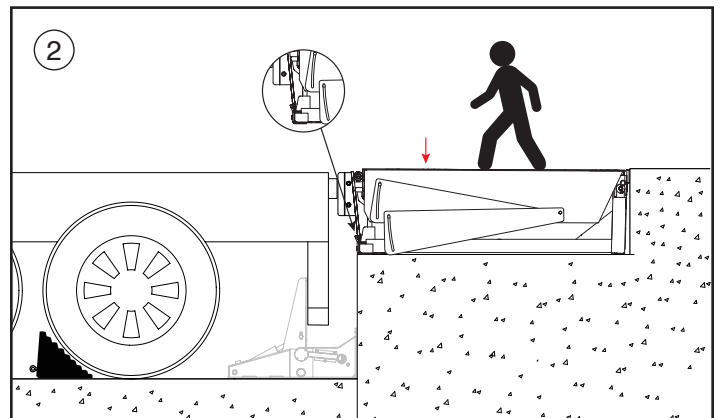
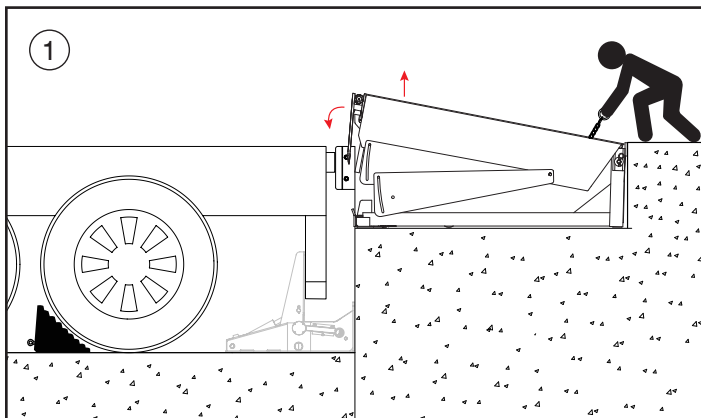

## 7.4 BELOW LEVEL / END LOADING

This section outlines dock leveler operation in situations where the lip cannot make contact with the vehicle load bed (i.e. loading or unloading the first skid or pallet from the truck when there is not enough room to extend the lip) or the truck height is below dock level.

1. Raise the leveler by pulling up the hold-down release ring at the rear of the deck. Until the deck is cleared of the lip keeper or about 6"-8" (152mm-203mm) above level. Release hold-down release ring.
2. Approach the front of the deck and pull the below level lip deployment chain until the lip extends enough to position it between the face of the dock and the trailer. Walk deck down to below level stops. Do not step on the lip.

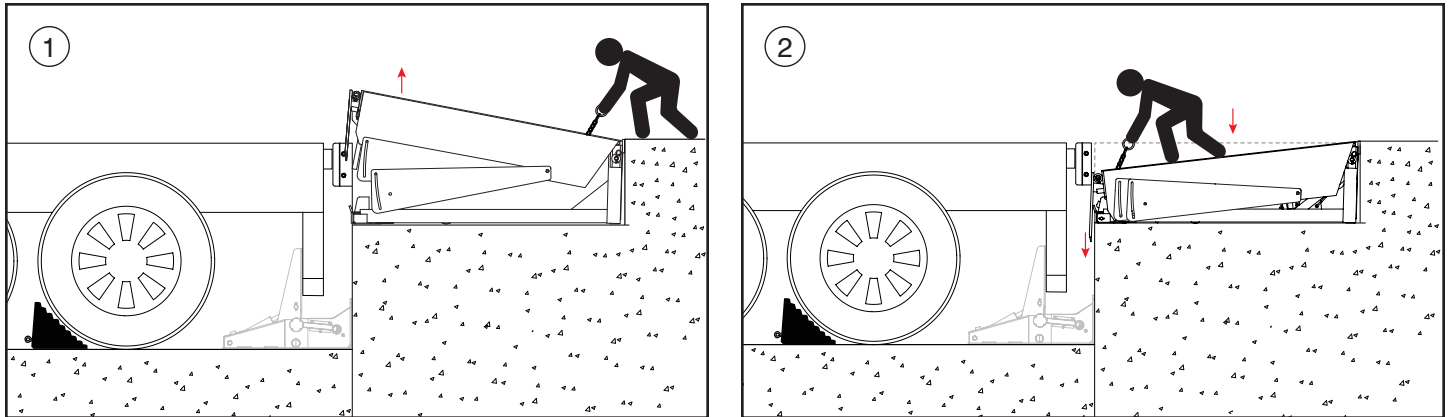

## 7.5 OVERRIDING THE FALL-SAFE OPTION

The mechanical fall-safe option consists of two support legs held rigidly in place by springs. Their purpose is to stop downward travel of the deck by approximately 2.5" (60 mm) below level position.

When situations arise that require the deck to be lowered more than 2.5" (60 mm) below the cross-traffic position, retract the fall-safe support legs via the lip deployment chain located at the left front corner of the deck. The lip deployment chain retracts the support legs and allows the dock leveler to lower a full 12" (304 mm) below level position. The support legs will return to the normal pendent position when the lip deployment chain is released and the deck has risen high enough via operation of the hold-down release ring.

**NOTE:** The deck must be raised 6"-8" (152mm-203mm) above level to operate the safety leg pull chain.

**8.0 RECOMMENDED SPARE PARTS - MECHANICAL DOCK LEVELER**

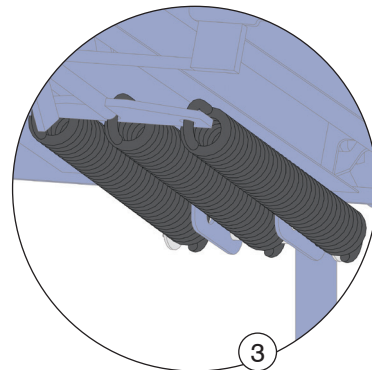
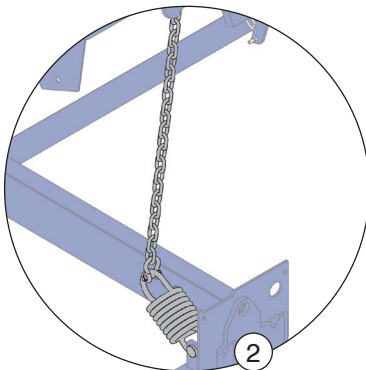
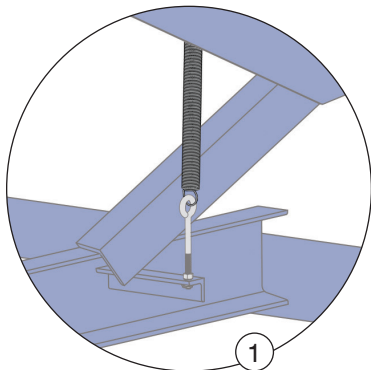

**8.1 RECOMMENDED SPARE PARTS - RATCHET HOLD-DOWN ASSEMBLY**

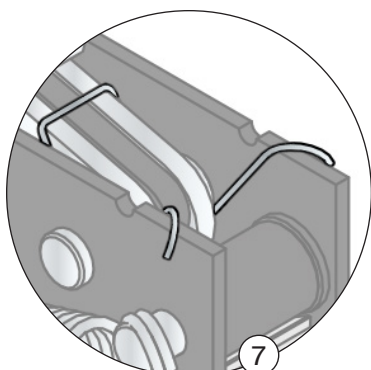
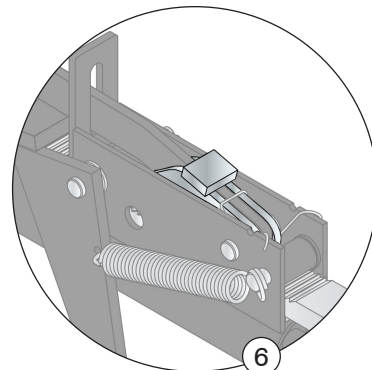
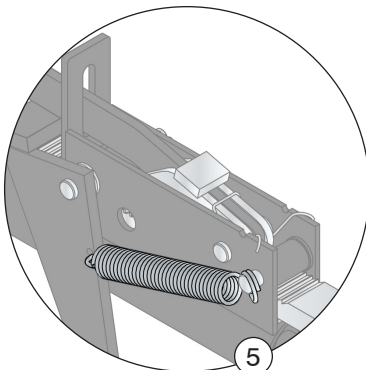
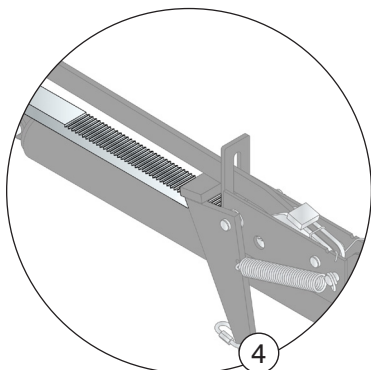

REPLACEMENT PARTS MECHANICAL DOCK LEVELER			
ITEM	PART NO.	DESCRIPTION	QTY REQ'D.
1	017-089	Tension Spring	1
2	1002455	Lip Activating Spring Assembly	1
3	2000446	Main Springs	3

REPLACEMENT PARTS RATCHET HOLD-DOWN ASSEMBLY			
ITEM	PART NO.	DESCRIPTION	QTY REQ'D.
4	22-002641	Ratchet Bar	1
5	70-003743	Tension Spring	1
6	22-002636	Pawl Assembly	1
7	22-002639	Spring, Retainer Pawl	1

9.0 DECAL IDENTIFICATION AND LOCATION

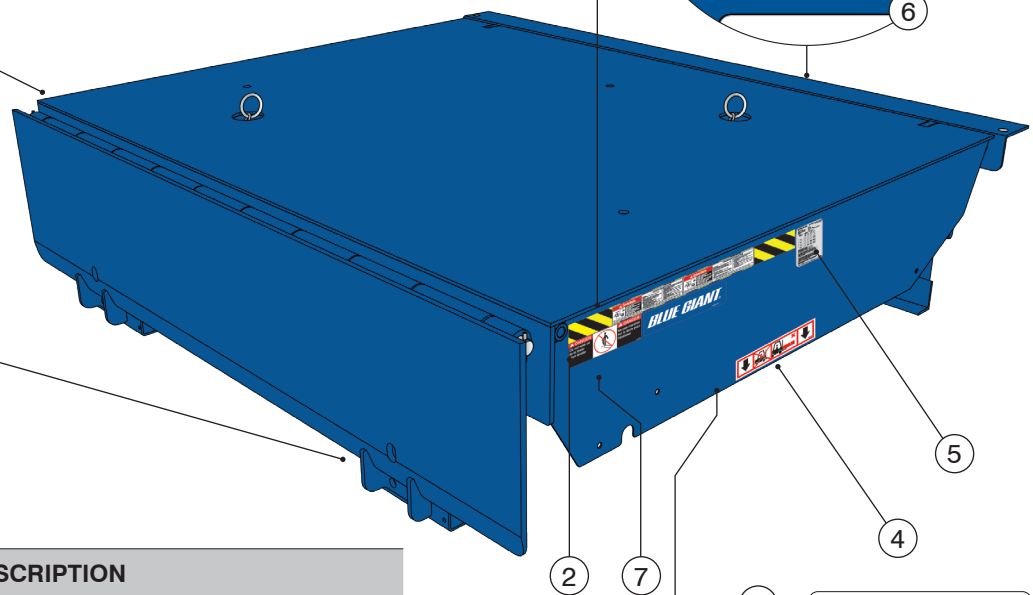
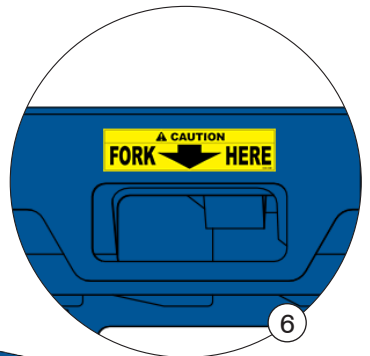
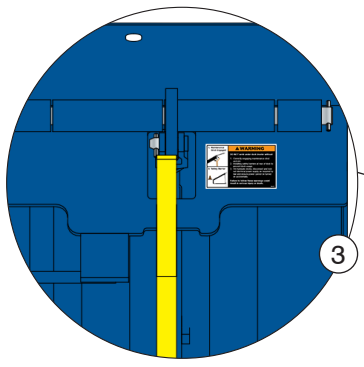
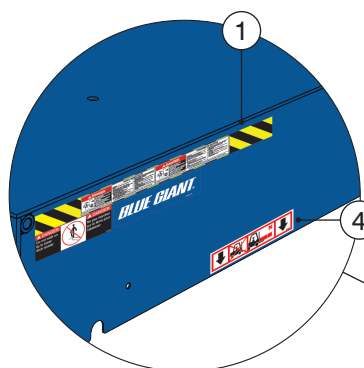
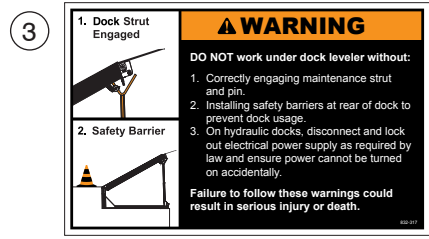
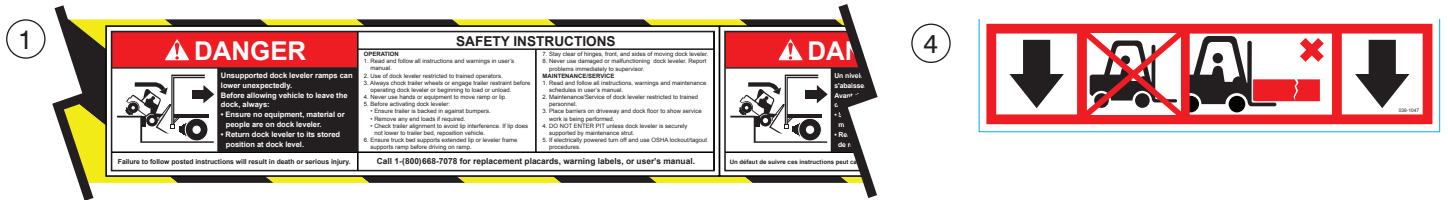

ITEM	QTY	PART NO.	DESCRIPTION
1	2	038-226	EF Danger Decal - Safety Instructions
			ES
2	2	038-220	EF Danger Decal - Do Not Walk on Lip
			ES
3	1	832-317	Warning Decal - Dock Strut
4	2	038-1047	Warning Decal - Do Not Lift on This Side
5	2	038-1082	EF Serial Plate Decal
			ES
6	2	038-098	Lift Caution Decal
7	2	038-017E	Blue Giant Logo Decal

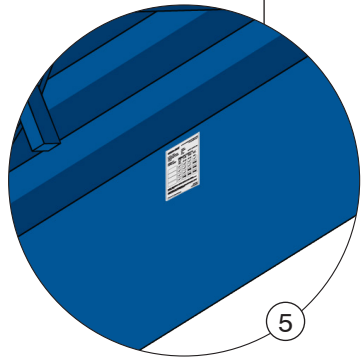

WORKHORSE		BLUE GIANT EQUIPMENT CORPORATION			
		www.bluegiant.com			
MODEL / MODELE	MY2016W				
SERIAL NO. / NO. DE SERIE	08798-01				
ELECTRICAL / ALIMENTATION	N/A				
WFO / FA#	04C018				
		(MM/YYYY)MM.AAAA			
GROSS LOAD WEIGHT (kg) /	USAGE / LOAD CYCLES (DAILY)				
		0-8	9-16	17-24	>24
		0-200	201-100	401-600	>600
<input type="checkbox"/>	<input checked="" type="checkbox"/>	<input checked="" type="checkbox"/>	<input checked="" type="checkbox"/>	<input checked="" type="checkbox"/>	<input checked="" type="checkbox"/>
<input type="checkbox"/>	<input checked="" type="checkbox"/>	<input checked="" type="checkbox"/>	<input checked="" type="checkbox"/>	<input checked="" type="checkbox"/>	<input checked="" type="checkbox"/>
<input type="checkbox"/>	<input checked="" type="checkbox"/>	<input checked="" type="checkbox"/>	<input checked="" type="checkbox"/>	<input checked="" type="checkbox"/>	<input checked="" type="checkbox"/>
<input type="checkbox"/>	<input checked="" type="checkbox"/>	<input checked="" type="checkbox"/>	<input checked="" type="checkbox"/>	<input checked="" type="checkbox"/>	<input checked="" type="checkbox"/>
<small>10 YEAR WARRANTY LIFE EXPECTANCY / 10 ANOS DE GARANTIA DE VIDA ESPERADA                  BASED ON 100% DUTY CYCLE / FOUNDED ON PROVEN TECHNOLOGY AND DESIGN                  WORKHORSE'S SERVICE OF YOUR BUSINESS IS OUR COMMITMENT. WE WILL NOT BE RESPONSIBLE FOR ANY DAMAGE TO YOUR BUSINESS OR EQUIPMENT.                  REFER TO SAFETY AND OPERATING INSTRUCTIONS IN YOUR OWNER'S MANUAL.</small>					
<small>COMPLIES WITH / CONFORME AVEC MODEL 608-100201                  MADE IN CANADA</small>					

EF = English / French | ES = English / Spanish



10.0 EQUIPMENT COMPONENT ILLUSTRATIONS

10.1 COMPONENTS AS SHIPPED CHECKLIST

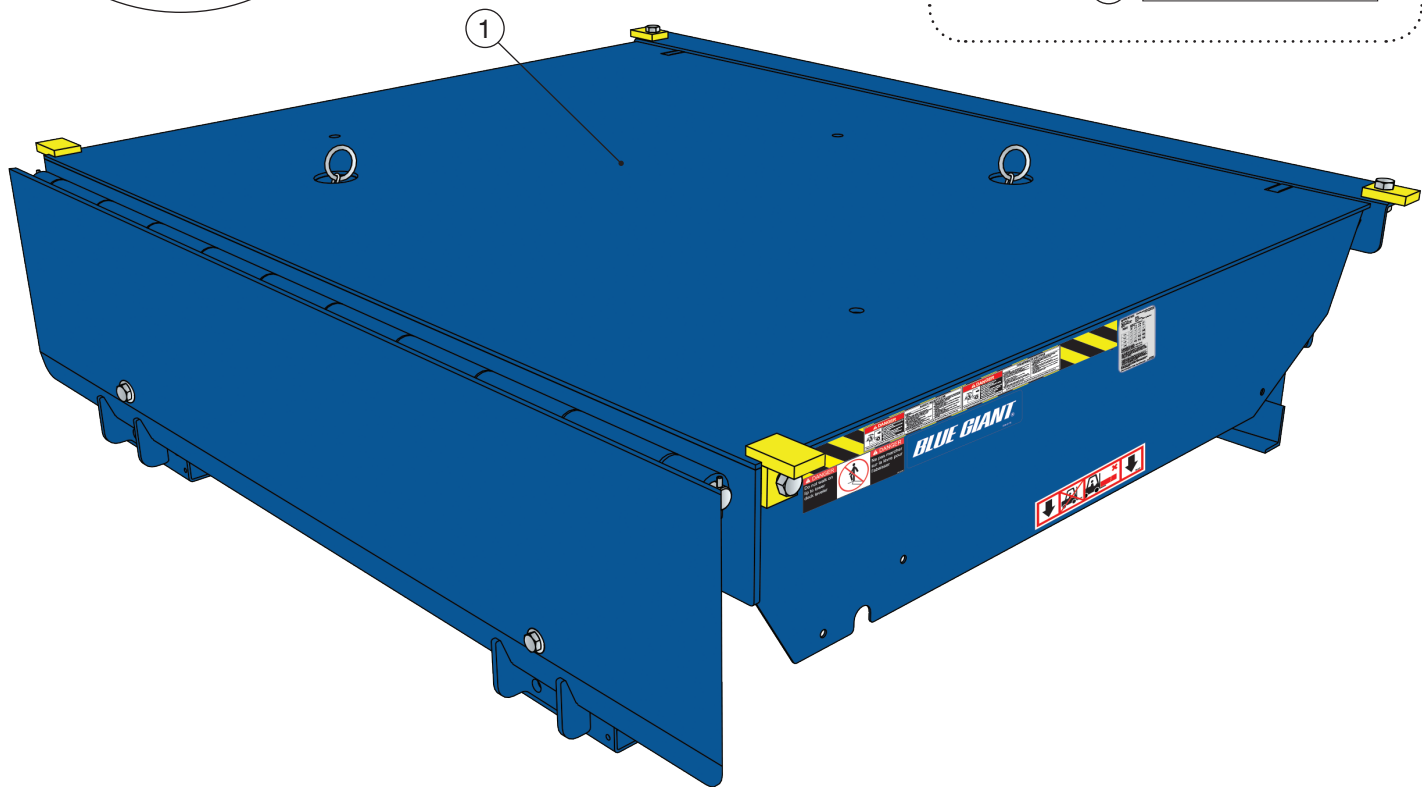
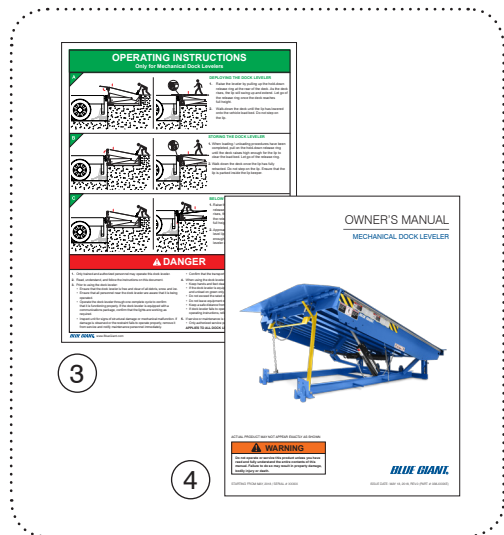
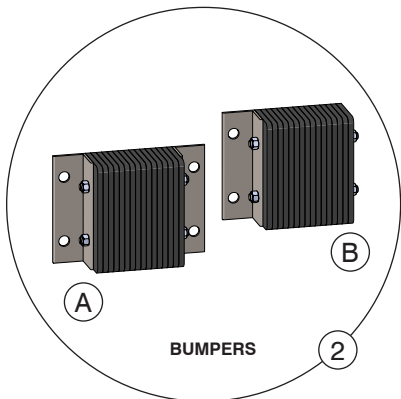

✓	ITEM	QTY	PART NO.	DESCRIPTION	APPROX. WEIGHT	
	1	1	MXXXXX	Mechanical Dock Leveler - See Section 10.5 for more information	Varies by Model	
	2	2	DB411	Laminated Bumper, Dual Flange	50 lb	23 kg
			DB411WB	Laminated Bumper, Single Flange	48 lb	22 kg
	3	1	038-1027E	Operation Placard	—	—
	4	1	038-1083E	Owner's Manual (this one)	—	—

10.2 MECHANICAL ASSEMBLY - MECHANICAL DOCK LEVELER

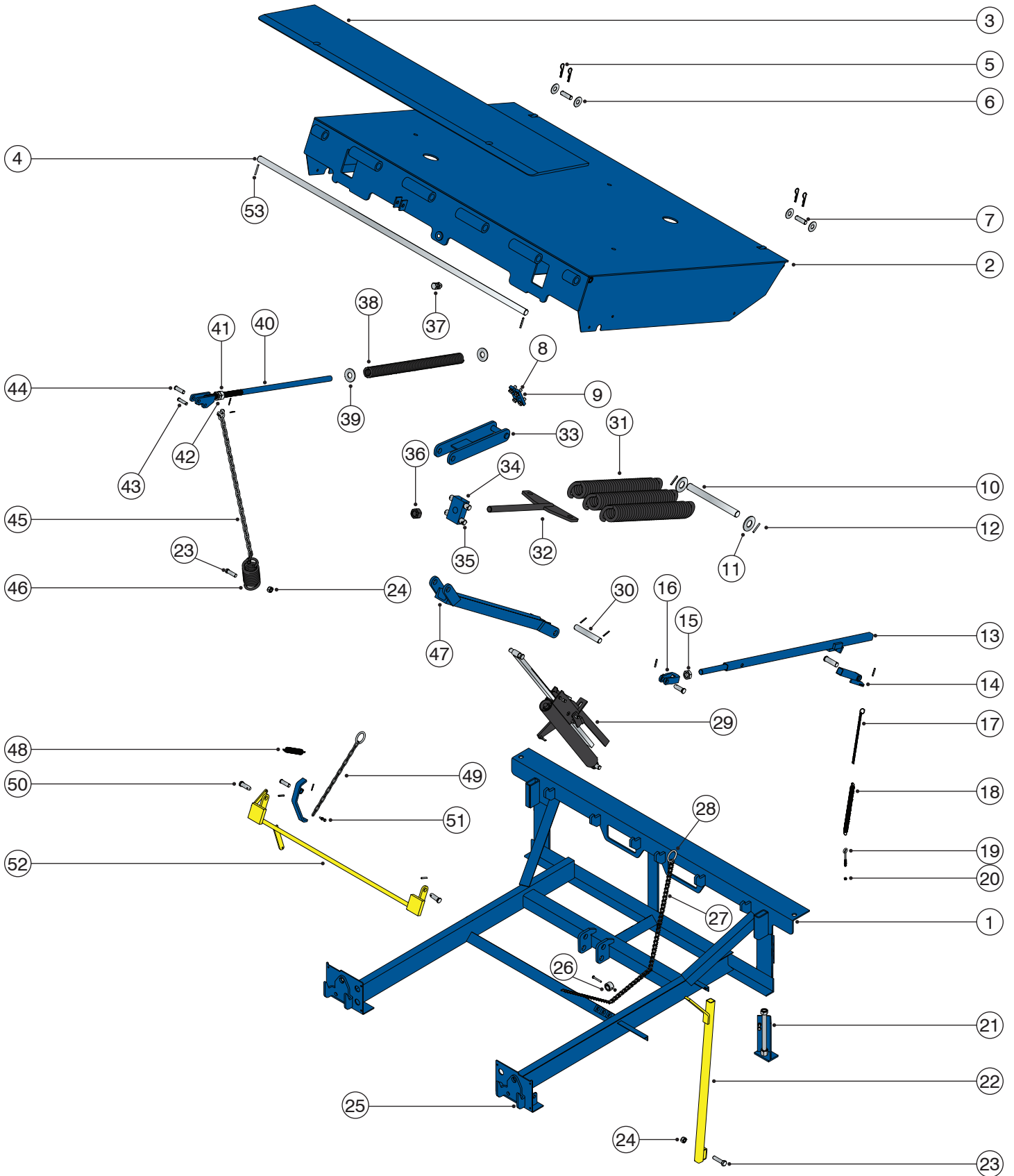

**10.3 MECHANICAL ASSEMBLY - MECHANICAL DOCK LEVELER CONT'D.**

ITEM	QTY.	PART NO.	DESCRIPTION
1	1	See Section 10.7	Frame
2	1	See Section 10.4	Deck
3	1	See Section 10.5	Lip
4	1	See Section 10.6	Lip Shaft
5	4	013-029	Cotter Pin 7/8 x 3 1/4
6	4	012-214	Flat Washer 3/4"
7	2	26-005610	Pin
8	4	010-246	Hex Head Cap Screw 1/2" x 1 1/2"
9	2	2002286	Cover Plate
10	1	See Section 10.9	Spring Holder Pivot Pin
11	2	012-216	Flat Washer
12	2	013-012	Pin
13	1	2001744	Lip Lock Bar Weldment
14	1	2000276	Dog Weldment
15	1	011-511	Hex Jam Nut 1-8
16	1	114-663	Clevis
17	1	090-882-0110	Sash Chain
18	1	017-089	Tension Spring
19	1	010-242	Routing Eyebolt 1/4-2-x3"L
20	2	011-545	Hex Lock Nut, Nylon Insert
21	4	2001750-1	Shimless Bracket
22	1	2000659	Dock Strut
23	2	011-134	Hex Head Cap Screw 5/8" x 3"
24	2	011-501	5/8" Lock Nut
25	2	2000402	Lip Keeper
26	1	1002299	Stop Block

ITEM	QTY.	PART NO.	DESCRIPTION
27	1	2001749-1	Ratchet Chain Assembly
28	1	1004597	Pull Ring
29	1	22-003769-1	Ratchet Hold-Down Assembly See Section 11.0 for more info
30	1	2000263-1	Pivot Pin
31	X	See Section 10.9	Main Spring
32	1	See Section 10.9	Spring Bracket Weldment
33	1	2002449	Upper Arm Weldment
34	1	2000321	Connecting Link
35	2	2000263	Pivot Pin
36	1	011-691	Hex Nut 1/8"
37	1	010-059	Hex Head Cap Screw 3/4" x 2"
38	1	1003131	Lip Assist Spring
39	2	012-253	Washer
40	1	2000017	Thread Rod Weldment
41	2	011-531	Hex Nut
42	2	011-511	Hex Jam Nut
43	1	013-629	Clevis Pin
44	2	013-628	Clevis Pin
45	1	2000520	Chain Assembly
46	1	1002455	Lip Activating Spring
47	1	2000335	Lower Arm Weldment
48	1	017-012	Tension Spring
49	1	2000578	Chain Assembly
50	4	107-196	Clevis Pin
51	2	011-545	Hex Lock Nut - Nylon Insert
52	1	2000403	Fall Safe Weldment
53	2	013-117	Spring Pin

### 10.4 DECK

By size and load class

DECK SIZE (NOMINAL)	LOAD CLASS	MODEL	PART NO.
6' x 6'	Workhorse (W)	M6006W	DECK-W-M-STD-72W-63L
	Heavy (H)	M6006H	DECK-H-M-STD-72W-63L
	Super (S)	M6006S	DECK-S-M-STD-72W-63L
6' x 8'	Workhorse (W)	M6008W	DECK-W-M-STD-72W-87L
	Heavy (H)	M6008H	DECK-H-M-STD-72W-87L
	Super (S)	M6008S	DECK-S-M-STD-72W-87L
6' x 10'	Workhorse (W)	M6010W	DECK-W-M-STD-72W-111L
	Heavy (H)	M6010H	DECK-H-M-STD-72W-111L
	Super (S)	M6010S	DECK-S-M-STD-72W-111L
6' 6" x 6'	Workhorse (W)	M6606W	DECK-W-M-STD-78W-63L
	Heavy (H)	M6606H	DECK-H-M-STD-78W-63L
	Super (S)	M6606S	DECK-S-M-STD-78W-63L
6' 6" x 8'	Workhorse (W)	M6608W	DECK-W-M-STD-78W-87L
	Heavy (H)	M6608H	DECK-H-M-STD-78W-87L
	Super (S)	M6608S	DECK-S-M-STD-78W-87L
6' 6" x 10'	Workhorse (W)	M6610W	DECK-W-M-STD-78W-111L
	Heavy (H)	M6610H	DECK-H-M-STD-78W-111L
	Super (S)	M6610S	DECK-S-M-STD-78W-111L
7' x 6'	Workhorse (W)	M7006W	DECK-W-M-STD-83W-63L
	Heavy (H)	M7006H	DECK-H-M-STD-83W-63L
	Super (S)	M7006S	DECK-S-M-STD-83W-63L
7' x 8'	Workhorse (W)	M7008W	DECK-W-M-STD-83W-87L
	Heavy (H)	M7008H	DECK-H-M-STD-83W-87L
	Super (S)	M7008S	DECK-S-M-STD-83W-87L
7' x 10'	Workhorse (W)	M7010W	DECK-W-M-STD-83W-111L
	Heavy (H)	M7010H	DECK-H-M-STD-83W-111L
	Super (S)	M7010S	DECK-S-M-STD-83W-111L

### 10.6 LIP SHAFT

By size and load class

DECK SIZE (NOMINAL)	LOAD CLASS	PART NO.
6'	Workhorse (W)	2000456-00
	Heavy (H)	
	Super (S)	2000456-03
6' 6"	Workhorse (W)	2000456-01
	Heavy (H)	2000456-04
	Super (S)	

### 10.5 LIP

By size and capacity

DECK WIDTH	CAPACITY	LENGTH		PART NO.
6'	Workhorse (W)	16"	406 mm	LIP-W-M-STD-FW-72W-16L
		18"	457 mm	LIP-W-M-STD-FW-72W-18L
		20"	508 mm	LIP-W-M-STD-FW-72W-20L
	Heavy (H)	16"	406 mm	LIP-H-M-STD-FW-72W-16L
		18"	457 mm	LIP-H-M-STD-FW-72W-18L
		20"	508 mm	LIP-H-M-STD-FW-72W-20L
	Super (S)	16"	406 mm	LIP-S-M-STD-FW-72W-16L
		18"	457 mm	LIP-S-M-STD-FW-72W-18L
		20"	508 mm	LIP-S-M-STD-FW-72W-20L
6' 6"	Workhorse (W)	16"	406 mm	LIP-W-M-STD-FW-78W-16L
		18"	457 mm	LIP-W-M-STD-FW-78W-18L
		20"	508 mm	LIP-W-M-STD-FW-78W-20L
	Heavy (H)	16"	406 mm	LIP-H-M-STD-FW-78W-16L
		18"	457 mm	LIP-H-M-STD-FW-78W-18L
		20"	508 mm	LIP-H-M-STD-FW-78W-20L
	Super (S)	16"	406 mm	LIP-S-M-STD-FW-78W-16L
		18"	457 mm	LIP-S-M-STD-FW-78W-18L
		20"	508 mm	LIP-S-M-STD-FW-78W-20L
7'	Workhorse (W)	16"	406 mm	LIP-W-M-STD-TP-83W-16L
		18"	457 mm	LIP-W-M-STD-TP-83W-18L
		20"	508 mm	LIP-W-M-STD-TP-83W-20L
	Heavy (H)	16"	406 mm	LIP-H-M-STD-TP-83W-16L
		18"	457 mm	LIP-H-M-STD-TP-83W-18L
		20"	508 mm	LIP-H-M-STD-TP-83W-20L
	Super (S)	16"	406 mm	LIP-S-M-STD-TP-83W-16L
		18"	457 mm	LIP-S-M-STD-TP-83W-18L
		20"	508 mm	LIP-S-M-STD-TP-83W-20L

**10.7 FRAME**

By size

DECK SIZE (NOMINAL)	LOAD CLASS	PART NO.
6' x 6'	Workhorse (W)	FRAME-W-M-72L-63W-20D
	Heavy (H)	FRAME-H-M-72L-63W-20D
	Super (S)	FRAME-S-M-72L-63W-20D
6' x 8'	Workhorse (W)	FRAME-W-M-72L-87W-20D
	Heavy (H)	FRAME-H-M-72L-87W-20D
	Super (S)	FRAME-S-M-72L-87W-20D
6' x 10'	Workhorse (W)	FRAME-W-M-72L-111W-20D
	Heavy (H)	FRAME-H-M-72L-111W-20D
	Super (S)	FRAME-S-M-72L-111W-20D
6' 6" x 6'	Workhorse (W)	FRAME-W-M-78L-63W-20D
	Heavy (H)	FRAME-H-M-78L-63W-20D
	Super (S)	FRAME-S-M-78L-63W-20D
6' 6" x 8'	Workhorse (W)	FRAME-W-M-78L-87W-20D
	Heavy (H)	FRAME-H-M-78L-87W-20D
	Super (S)	FRAME-S-M-78L-87W-20D
6' 6" x 10'	Workhorse (W)	FRAME-W-M-78L-111W-20D
	Heavy (H)	FRAME-H-M-78L-111W-20D
	Super (S)	FRAME-S-M-78L-111W-20D

DECK SIZE (NOMINAL)	LOAD CLASS	PART NO.
7' x 6'	Workhorse (W)	FRAME-W-M-83L-63W-20D
	Heavy (H)	FRAME-H-M-83L-63W-20D
	Super (S)	FRAME-S-M-83L-63W-20D
7' x 8'	Workhorse (W)	FRAME-W-M-83L-87W-20D
	Heavy (H)	FRAME-H-M-83L-87W-20D
	Super (S)	FRAME-S-M-83L-87W-20D
7' x 10'	Workhorse (W)	FRAME-W-M-83L-111W-20D
	Heavy (H)	FRAME-H-M-83L-111W-20D
	Super (S)	FRAME-S-M-83L-111W-20D

**10.8 STANDARD PIT DIMENSIONS**

NOMINAL SIZE		PIT WIDTH (W)		PIT LENGTH (L)	
		in	mm	in	mm
6' x 6'	1829 x 1829mm	74	1880	63	1600
6' x 8'	1829 x 2438mm			87	2210
6' x 10'	1829 x 3048mm			111	2819
6' 6" x 6'	1981 x 1829mm	80	2032	63	1600
6' 6" x 8'	1981 x 2438mm			87	2210
6' 6" x 10'	1981 x 3048mm			111	2819
7' x 6'	2133 x 1829mm	85	2159	63	1600
7' x 8'	2133 x 2438mm			87	2210
7' x 10'	2133 x 3048mm			111	2819

<b>Lip Length:</b>	16", 18", 20" (406, 457, 508 mm)	
<b>Standard Frame Depth:</b>	<b>Front:</b> 19.5" (495 mm)	<b>Rear:</b> 19" (483 mm)
<b>Standard Pit Depth:</b>	<b>Front (H):</b> 20" (508 mm)	<b>Rear (H1):</b> 19.5" (495 mm)

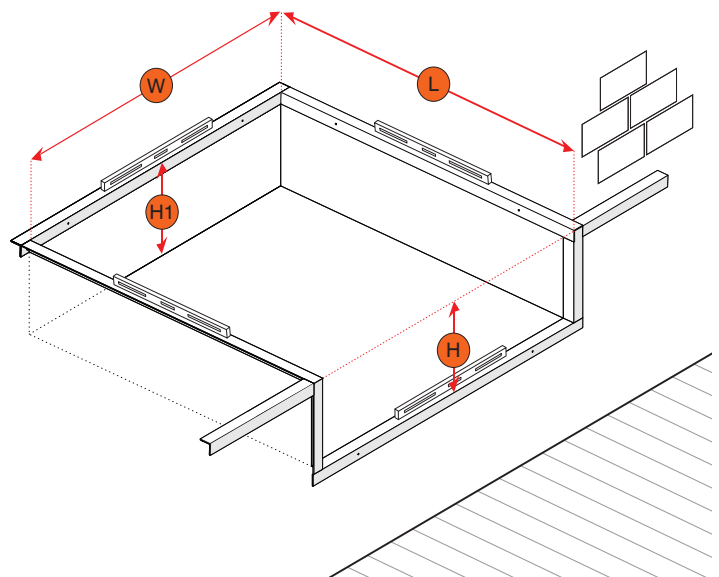

**Alternatives available:**

- Frame Length (Longer/Shorter)
- Frame Depth (Deeper/Shallower)
- Other Options – Consult Factory

**10.9 SPRING CONFIGURATION**

By size and load class

DECK SIZE (NOMINAL)	LOAD CLASS	SPRING PIVOT PIN (ITEM 10)	SPRING (ITEM 31)		SPRING BRACKET (ITEM 32)
		PART NO.	QTY.	PART NO.	PART NO.
6' x 6'	Workhorse (W)	2000263-2	3	24-012508-1	2000322
	Heavy (H)				
	Super (S)				
6' x 8'	Workhorse (W)	2000263-2	2	2000446	2000322
	Heavy (H)				
	Super (S)				
6' x 10'	Workhorse (W)	2000263-2	3	2000446	2000322
	Heavy (H)				
	Super (S)				
6' 6" x 6'	Workhorse (W)	2000263-2	3	24-012508-1	2000322
	Heavy (H)				
6' 6" x 6'	Super (S)	2000263-3	4	24-012508-1	2001874
	6' 6" x 8'	Workhorse (W)	2000263-2	2	2000446
Heavy (H)		1		2000446	
Super (S)				24-012508-1	
6' 6" x 10'	Workhorse (W)	2000263-2	3	2000446	2000322
	Heavy (H)				
	Super (S)				
7' x 6'	Workhorse (W)	2000263-3	4	24-012508-1	2001874
	Heavy (H)				
	Super (S)				
7' x 8'	Workhorse (W)	2000263-2	2	2000446	2000322
	Heavy (H)		1	24-012508-1	
Super (S)					
7' x 10'	Workhorse (W)	2000263-2	3	2000446	2000322
	Heavy (H)				
	Super (S)				

11.0 RATCHET HOLD-DOWN ASSEMBLY

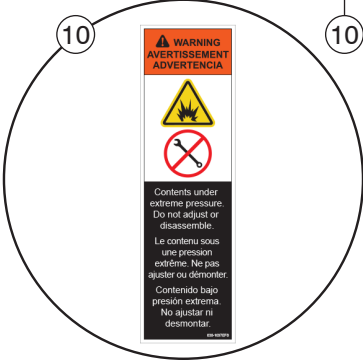
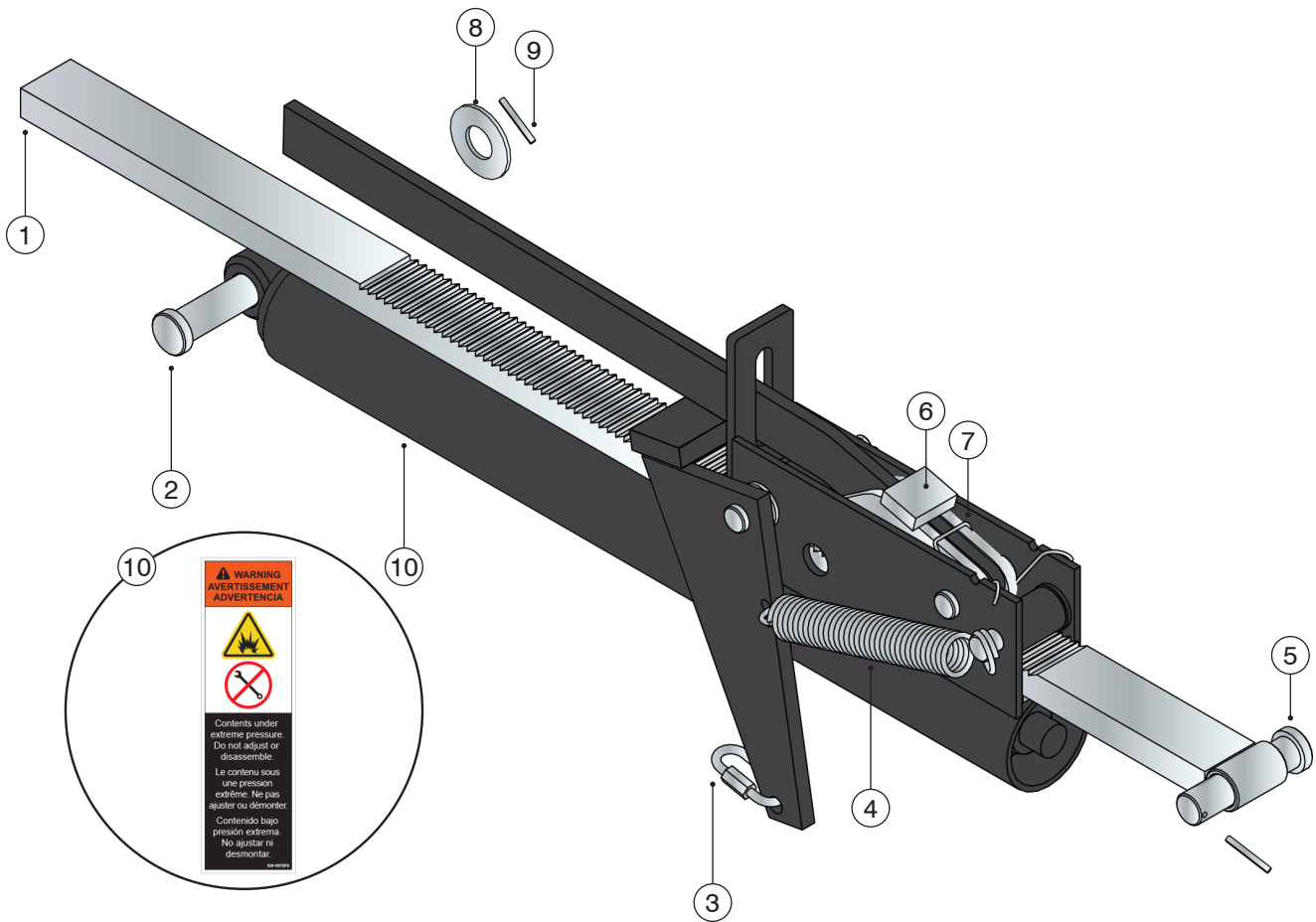

RATCHET HOLD-DOWN ASSEMBLY - 22-003769-1			
ITEM	PART NO.	DESCRIPTION	QTY REQ'D.
1	22-002641	Ratchet Bar	1
2	22-002092	Clevis Pin, Base	1
3	013-507	3/16" Chain, Quick Link	1
4	70-003743	Tension Spring	1
5	22-002092-1	Clevis Pin, Top	1
6	22-002636	Pawl Assembly	1
7	22-002639	Spring, Retainer Pawl	1
8	012-266	Flat Washer	1
9	013-022	Cotter Pin 1/8" x 1 1/2"	2
10	038-1037EFS	Warning Decal - Contents Under Pressure	1

## 12.0 TOE GUARDS

The Mechanical Dock Leveler features fixed toe guards on either side of the deck that closes the gap between the floor and the sides of the leveler while the dock is in **working range** (i.e. when the lip is on the trailer bed and 12" (305 mm) max. above the floor). Additional toe guards (highlighted below) are available as an option that closes the gap between the floor and sides of the leveler while the dock is in **operational range** (i.e. when deck is raised to its maximum height during the deployment process).

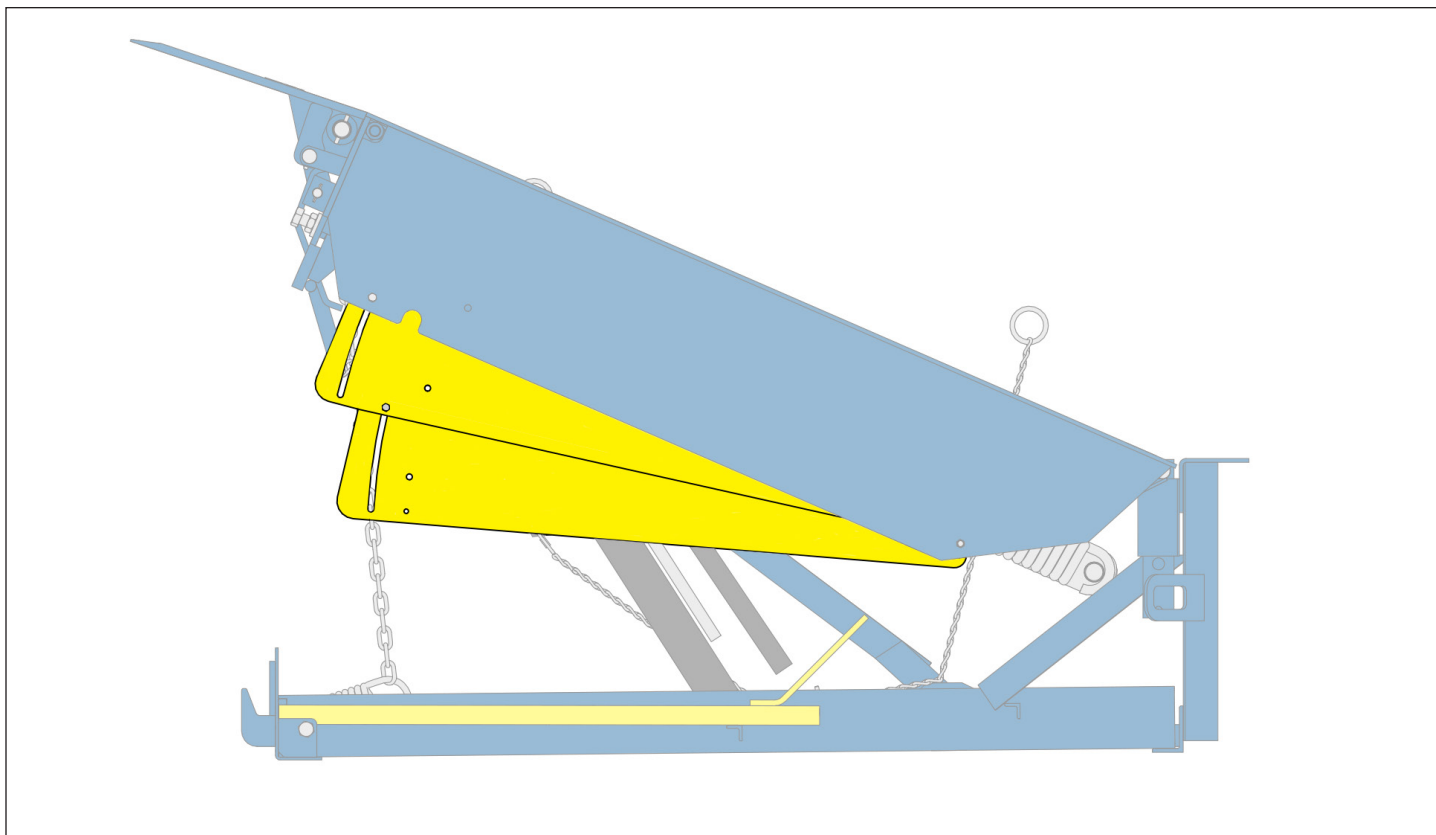

QTY.	PART NO.	DESCRIPTION
1 pkg. of 4 (includes hardware)	202-5024-99	Toe Guards for 6-8' Deck Size
1 pkg. of 4 (includes hardware)	202-5024-1-99	Toe Guards for 10' Deck Size



**13.0 DOCK LEVELER TROUBLESHOOTING****WARNING**

Do not attempt to install, make repairs or adjustments. Only a trained and authorized service technician should perform the installation process. Contact your local dealer or distributor for assistance.

PROBLEM	PROBLEM CAUSE
Deck will not raise	<ol style="list-style-type: none"> <li>1. Hold-down mechanism is not releasing. The release chain or handle may be jammed or broken.</li> <li>2. Foreign materials may be lodged between the side of the deck and the pit wall.</li> <li>3. The bumpers may be damaged or missing, allow the truck to contact and hold the lip.</li> <li>4. The lifting chain may be routed incorrectly.</li> <li>5. Missing/Broken spring(s).</li> <li>6. Main spring adjustment not adjusted properly.</li> </ol>
The deck does not raise quickly enough to swing the lip up into the fully extended position	<ol style="list-style-type: none"> <li>1. Deck may be dragging on the side of the pit, slowing its movement.</li> <li>2. Foreign material may be lodged between the side of the deck and the pit wall.</li> <li>3. Side brush seals may be coming loose.</li> <li>4. Lack of lubrication. Check rear and front hinges and the four lubrication points on the arm.</li> <li>5. Ensure that you are not standing on the deck while attempting to operate the dock.</li> <li>6. Check snubber chain.</li> <li>7. Lifting springs may require adjustment (rule out all other causes first).</li> </ol>
The lip does not lock after fully extending	<ol style="list-style-type: none"> <li>1. The lip lock is not engaging. The spring may be broken or stretched, or the lock may have seized.</li> <li>2. The lip actuator is bent or broken.</li> <li>3. Foreign material is lodged in the lip lock mechanism.</li> <li>4. Foreign object between the spools of the lip and the deck.</li> <li>5. The lip spool is seizing, rusted or damaged spool.</li> </ol>
The deck will not "walk down" or is difficult to "walk down"	<ol style="list-style-type: none"> <li>1. Foreign material in the pit may be blocking the mechanism.</li> <li>2. Side safety skirts are damaged and jammed against the wall.</li> <li>3. The dock strut is engaged.</li> <li>4. The ratchet assembly may be damaged.</li> <li>5. Weather seals, skirts, or deck may be dragging against the pit wall.</li> <li>6. The lift springs are improperly adjusted. Tension may have been mistakenly increased to troubleshoot another problem.</li> <li>7. The ratchet assembly be damaged.</li> </ol>

**13.0 DOCK LEVELER TROUBLESHOOTING CONT'D.**

⚠	WARNING
---	---------

Do not attempt to install, make repairs or adjustments. Only a trained and authorized service technician should perform the installation process. Contact your local dealer or distributor for assistance.

PROBLEM	PROBLEM CAUSE
The deck does not stay down: it springs back up after being walked down	<ol style="list-style-type: none"> <li>1. The pull chain is stuck in the open position.</li> <li>2. The ratchet pawl teeth are broken.</li> <li>3. The ratchet assembly mounts are broken.</li> <li>4. The ratchet pawl has a foreign object preventing it from locking into place.</li> <li>5. Missed adjusted auto collar.</li> <li>6. One or both springs damage or missing in ratchet assembly.</li> </ol>
The lip strikes the rear of the truck as the deck raises, stops, or slows down, and lip does not extend in the locked position	<ol style="list-style-type: none"> <li>1. Damaged or missing dock bumpers allow the truck to park too close to the dock leveler.</li> <li>2. Height difference between the dock and truck bed may be greater than recommended.</li> <li>3. The lip actuator assembly may be damaged, causing the lip to extend too early in the cycle.</li> <li>4. The lip actuator requires adjustment.</li> </ol>
The lip will not clear the rear of the truck when attendant attempts to park the dock while the truck is parked	<ol style="list-style-type: none"> <li>1. Damaged or missing dock bumpers allow the truck to park too close to the dock leveler.</li> <li>2. Height difference between the dock and truck bed may be greater than recommended.</li> <li>3. The lip actuator requires adjustment.</li> <li>4. The lip crown is set too high.</li> </ol>
The lip does not release or swing down when the truck departs	<ol style="list-style-type: none"> <li>1. The lip lock may have seized due to lack of lubrication, or due to foreign material in the pit.</li> <li>2. The lip lock may be held in the locked position by foreign material in the pit.</li> <li>3. No traffic when over deck to break lip lock.</li> </ol>

14.0 OPTIONAL TLC24 CONTROLS

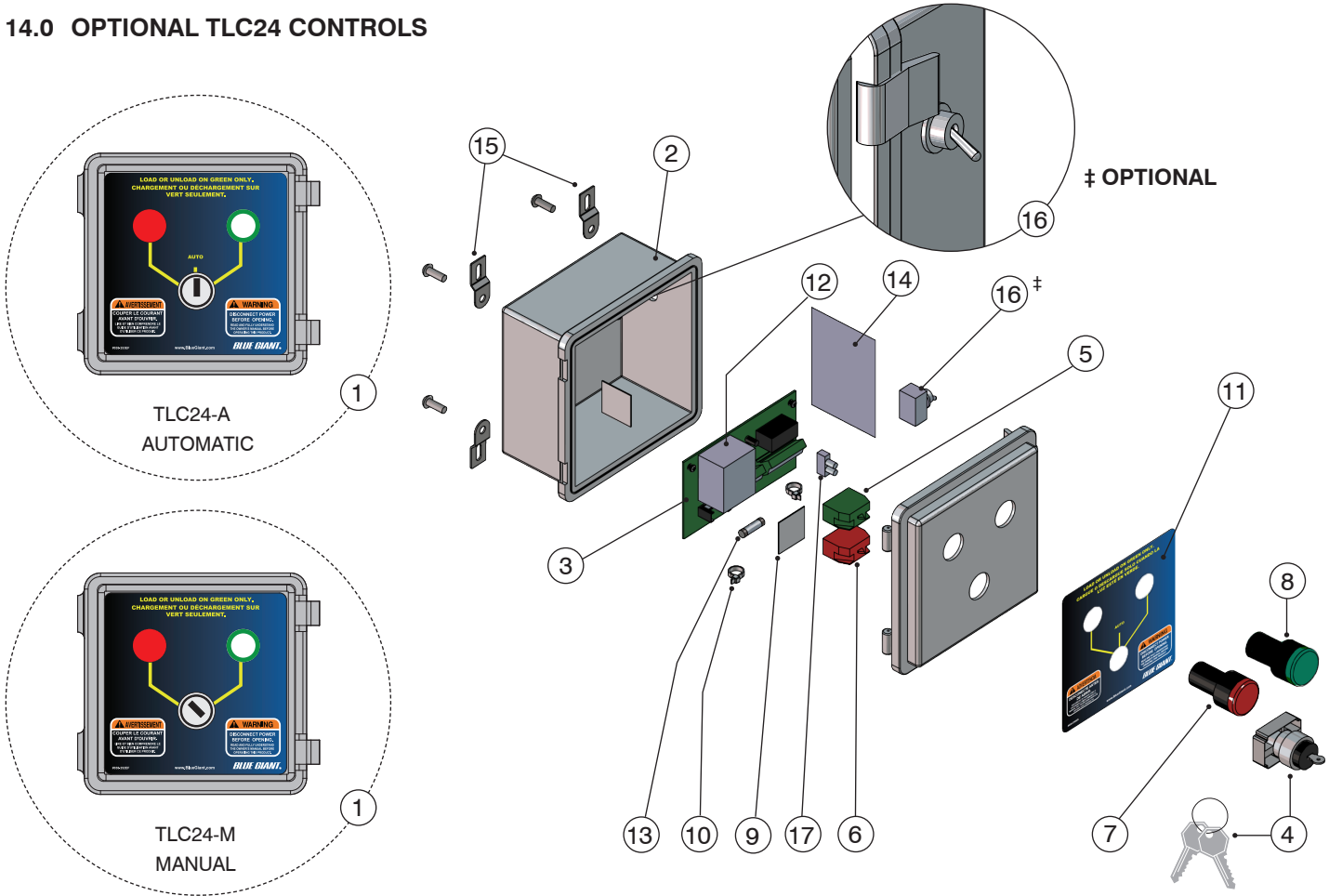

COMPLETE CONTROL STATION ASSEMBLY ITEM # 1					
(Example: TLC24A1115F)					
ITEM	QTY.	PART NO.	DESCRIPTION	ASSY PART #	
2	1	025-G023-M	Enclosure		
3	1	026-G014-1115	Traffic Lights Controller Board	TLC-24__1115	F
				S	
		026-G014-1230		TLC-24__1230	F
				S	
4	1	026-G201	3 Position Key Selector Switch	A*	
		026-G207	2 Position Key Selector Switch	M*	
5	1	026-G202	No Contact Block		
6	1	026-G203	No Contact Block		
7	1	026-G205	24V Monoblock LED Indicator – Red		
8	1	026-G206	24V Monoblock LED Indicator – Green		
9	2	025-062	Cable Tie Mount		
10	2	522-008	Tie Wire YS-98C		

COMPLETE CONTROL STATION ASSEMBLY ITEM # 1			
(Example: TLC24A1115F)			
ITEM	QTY.	PART NO.	DESCRIPTION
11	1	038-252EF	Decal, Automatic Light System
		038-252ES	
		038-253EF	Decal, Manual Light System
		038-253ES	
12	3	010-216	Screw, M4 x 8 PAN PHIL
13	1	026-G121	Fuse F.A. 100mA, 250V 5 x 20mm
14	1	WD-169	TLC24A Field Wiring Diagram
		WD-168	TLC24M Field Wiring Diagram
15	1	025-G010-1	Mounting Tabs With Hardware (1 pkg of 4)
16	1	026-G209	On/Off Switch ± Optional
17	1	025-172-1	Terminal Blocks, 0.32in x11

\*A = Automatic \*M = Manual

**15.0 OPTIONAL EXTERIOR TRAFFIC LIGHT / MIRROR IMAGE SIGN**

Slim-build LED traffic lights and mirror image drive warning sign improve loading dock safety.

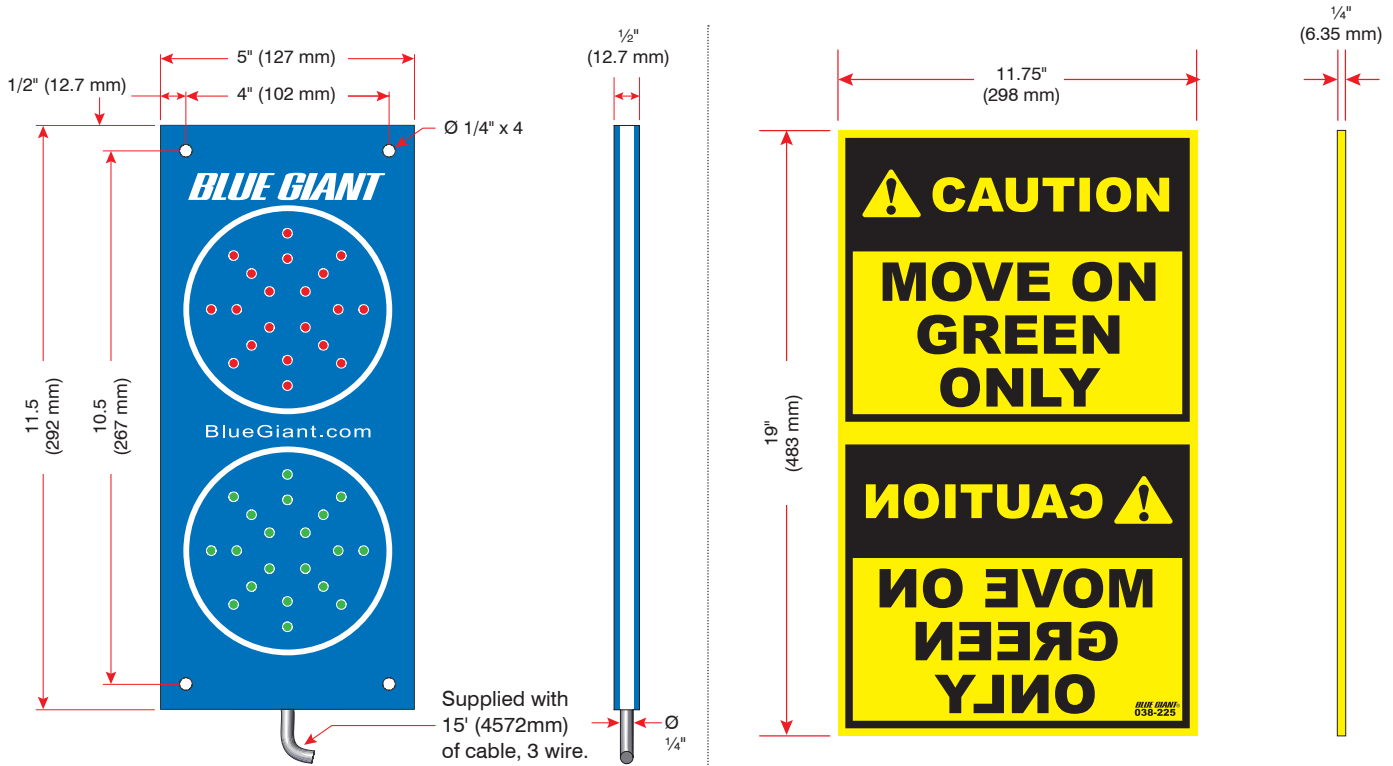

Exterior driver traffic light, part # 032-461.

Exterior driver warning sign, part # 038-225.  
(French 038-225F / Spanish 038-225S / Portuguese 038-225P)

**NOTICE**

Mount to a flat surface. **DO NOT** deform light housing with irregular wall surface.

**NOTICE**

Mount to a flat surface. **DO NOT** deform sign or drill mounting holes too close to edges.

**15.1 OPTIONAL HOME INTERLOCK SENSOR**

- Ties sequence of restraint to dock leveler operation
- Loading dock safety is improved with accurate operation sequence
- Interior traffic light and restraint release operation relies on interlock capability
- Mounted at parked position of any leveler

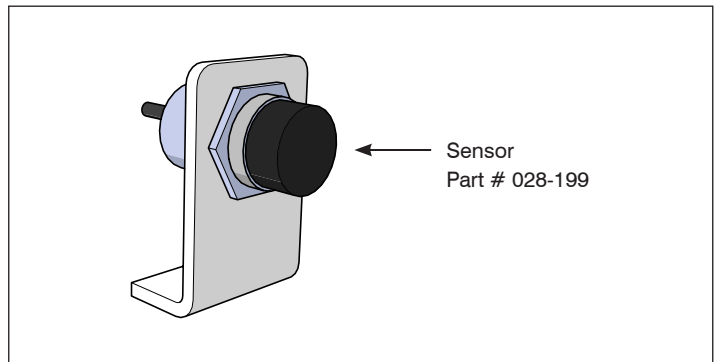

Home interlock sensor (home/lip sensor), part # 26-011290.

**16.0 WIRING DIAGRAMS**

**NOTICE**

The following wiring diagrams are sample configurations only. Wiring diagrams specific to your needs will be provided inside the control panel and/or as part of your submittal package.

16.1 WIRING DIAGRAM—TLC24-A 115V AND 230V SINGLE PHASE (AUTOMATIC)

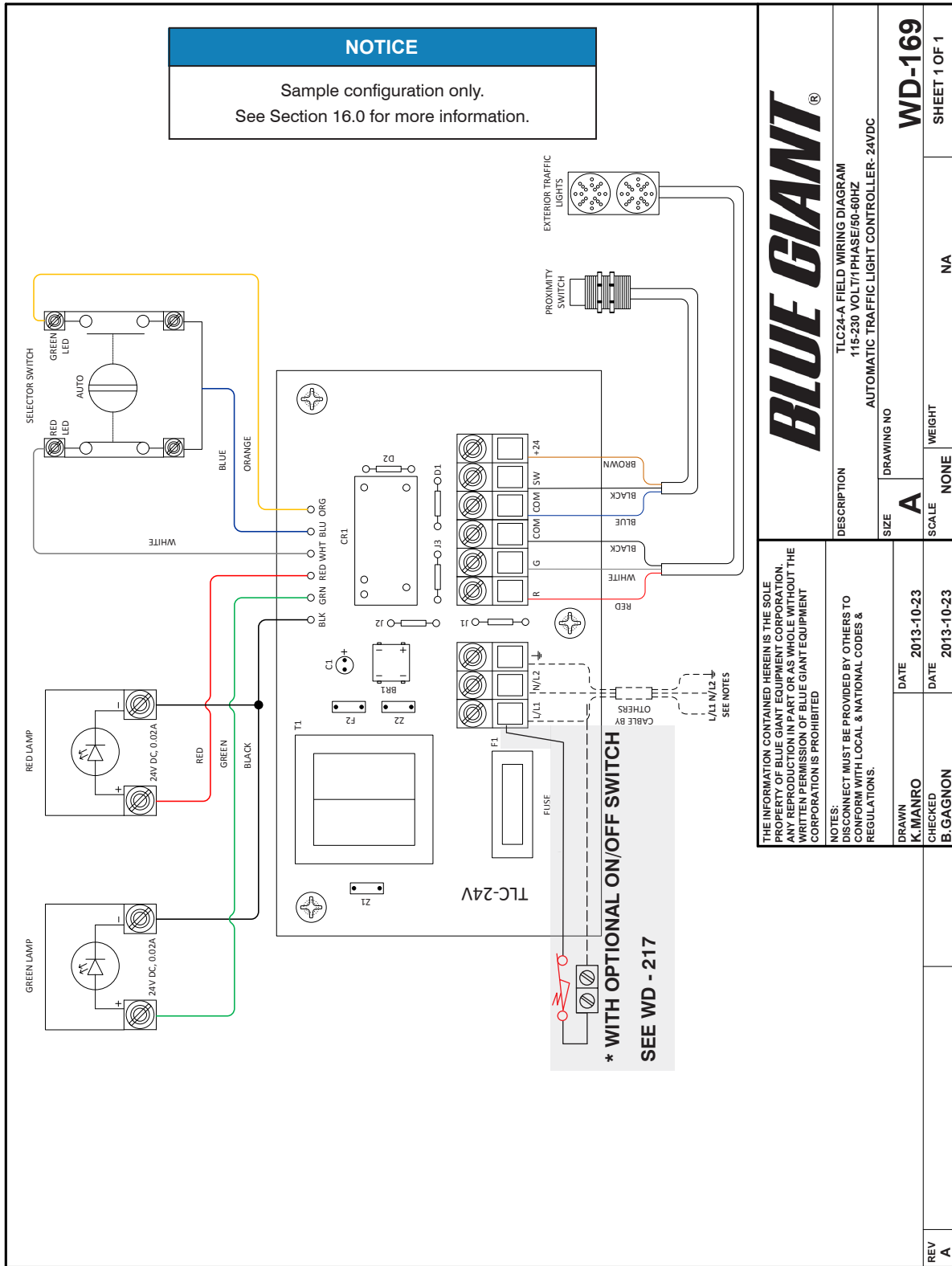

16.2 WIRING DIAGRAM—TLC24-M 115V AND 230V SINGLE PHASE (MANUAL)

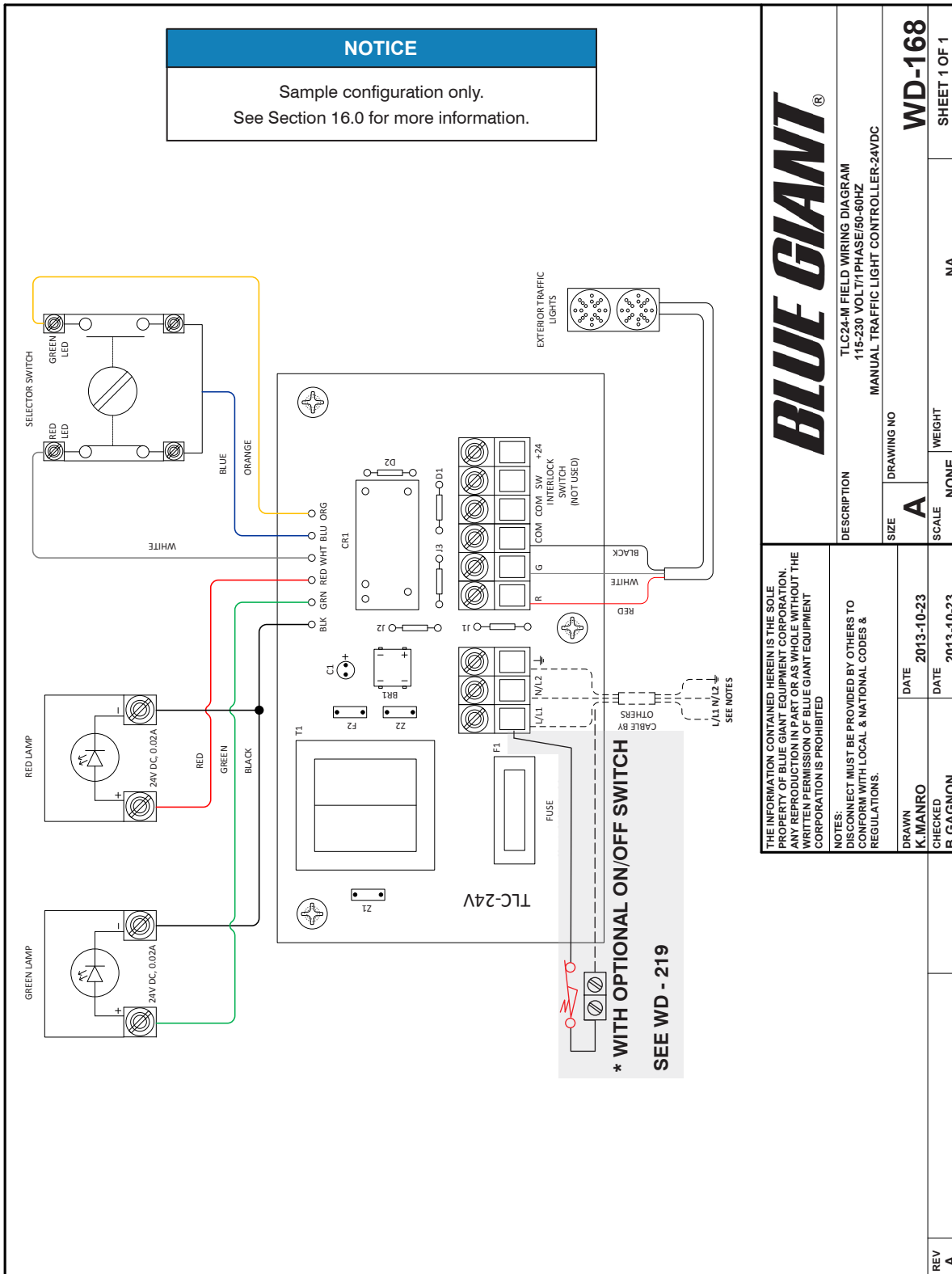

**NOTES**

# WARRANTY

## BLUE GIANT STANDARD WARRANTY

**Blue Giant** warrants its products to be free from defects in design, materials and workmanship for a period of 365 days from time of installation or sixty (60) days from the date of shipment, whichever comes first. All claims of warranty must be made within 30 days of when the defect is or can be detected, with reasonable care and no more than 30 days after the warranty period has expired. In order to be entitled to the benefits of this warranty the products must have been properly installed, maintained and operated by trained personnel in compliance with the manufacturer's recommendations with regards to rated capacities and/or design specific parameters, and not otherwise abused. Periodic adjustment, lubrication and maintenance are the sole responsibility of the end user.

This warranty is in lieu of any other warranties, either expressed or implied, including but not limited to any implied warranty of merchantability or fitness for a particular purpose. There are no warranties which extend beyond the description contained herein.

Non-standard warranties, if any, must be specified in writing by Blue Giant.

Blue Giant shall remedy any defects covered under this warranty by replacing or repairing, any defective equipment or parts while incurring all reasonable expenses for parts, labor and freight and shall be the exclusive remedy for all claims whether based on contract, negligence or strict liability.

## LIMITATION OF LIABILITY

**Blue Giant** does not assume responsibility or liability for loss of use of any equipment or incidental, consequential or special damages, or for loss of profit or damage to trade or business which results from the equipment.

**BLUE GIANT**  
BLUE GIANT EQUIPMENT CORPORATION

**Corporate** 410 Admiral Blvd  
Mississauga, ON, Canada L5T 2N6  
t 905.457.3900 f 905.457.2313

**USA** 6350 Burnt Poplar Road  
Greensboro, NC 27409  
[www.bluegiant.com](http://www.bluegiant.com)