



ENTRE//MATIC



DYNACO D-501 HIGH PERFORMANCE DOOR

Push-Pull
gear driven technology

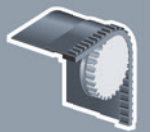

interior door

www.dynacodoor.us

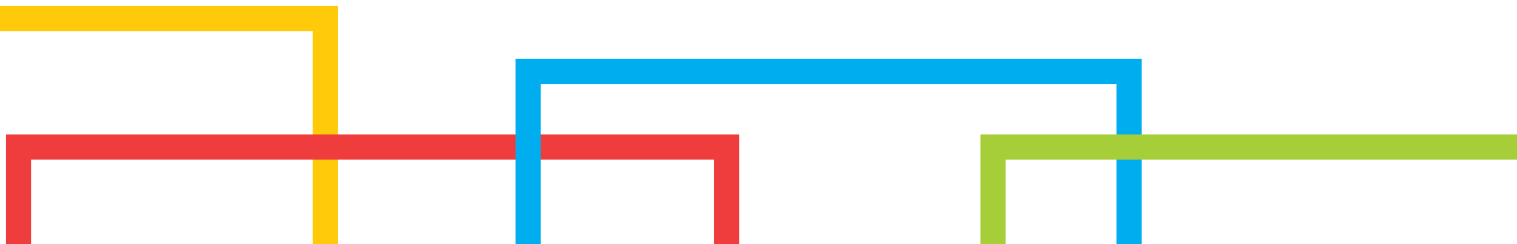

DYNACO D-501 HIGH PERFORMANCE DOOR

The DYNACO D-501 is designed for interior applications to 324 ft² providing safe and reliable high cycle operation.

Patented push-pull technology and advanced 1-piece belt design offers superior performance in moderate pressure environments while enhancing energy savings and reducing maintenance. Ultra quiet high-speed operation combined with soft curtain design improves traffic flow and increases safety for users and goods.

■ DOOR OPERATION

Gear driven 1-piece belt push-pull system eliminates rigid and damage prone components and provides high speed closing, even under pressure.

■ PATENTED GUIDE AND SEAL TECHNOLOGY

Galvanized steel guides with pivoting, spring loaded UHMW inner side guides allow for movement and deflection under pressure. The inner profile perfectly encapsulates the curtain drive belt, forming a near perfect seal.

■ SAFETY ENGINEERED

The door panel is constructed from a selection of soft, pliable UV and puncture resistant materials, which protect workers, equipment and products against 4 different types of accidents. Additional safety features include a wireless reversing edge and built-in thru-beam photo-eyes.

■ ADVANCED DRIVE AND CONTROL

IP65 rated direct drive unit with soft start/stop technology, absolute encoder and electronic braking for smooth operation. Our DYNALOGIX II controller is user friendly and provides self-diagnostic and programming functions for reliable, safe and productive environments.

Safe

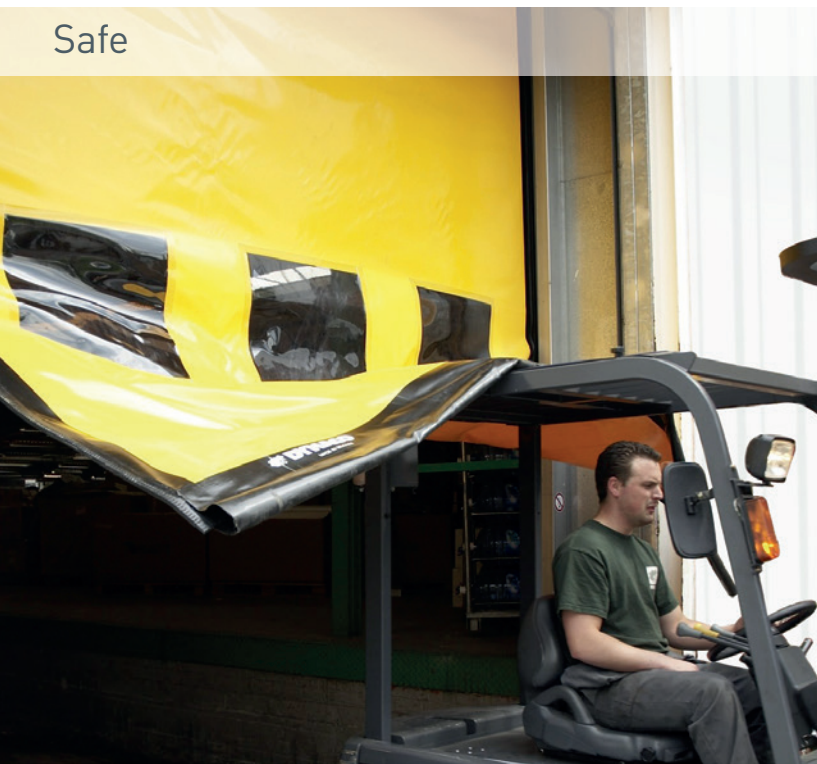

Patented "PUSH-PULL" Drive technology

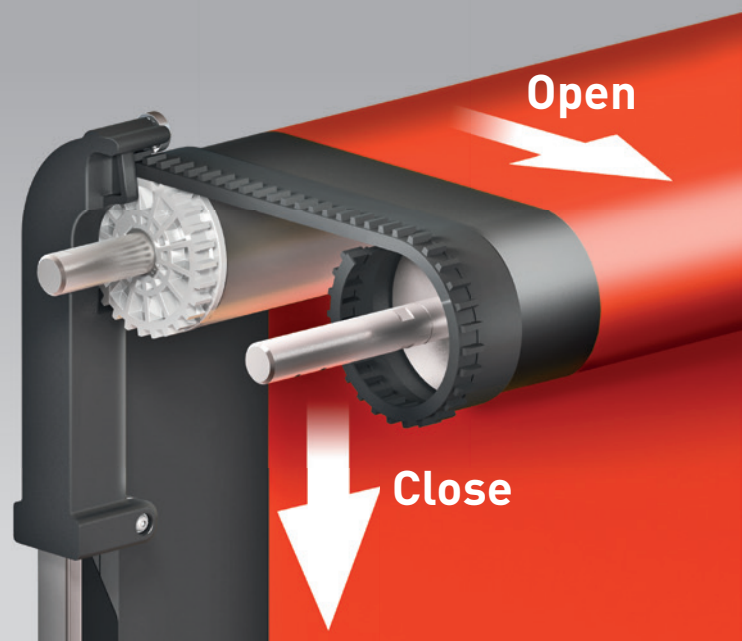

Push-Pull

gear driven technology

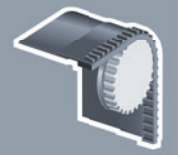

interior door

■ HIGH SPEED OPERATION

Depending on door size operation speeds up to 96" per second opening and standard 48" per second close provide energy savings, environmental control and workflow productivity.

■ WARRANTY

An industry leading 5 year warranty on the drive motor and 5 year warranty on manufacturing defects on the curtain. One year on balance of components.

TECHNICAL SPECIFICATIONS

Standard door dimensions	Minimum: 6'W x 6'H Maximum: 18'W x 18'H
Operating speed	Up to 96" per second open 48" per second close standard
Safety features	Wireless reversing edge and built-in infrared sensors, no coil cords.
Door panel	27oz reinforced PVC vinyl, with your choice of color and vision. Optional Dynalumin daylight fabric available.

TECHNICAL SPECIFICATIONS

Wind resistance	Resists static pressure of 14.62psf; width over 13' to resist 9.9psf.
Door components	Direct Drive Unit. Side frames constructed of structural channels of 3 1/8" x 1 9/16" x 1/8" galvanized steel. Inner guides in polyethylene (PE-UHMW 1000).
Control and drive System	UL approved control system housed in NEMA 4 enclosure. DYNALOGIX II controller with variable frequency drive and high resolution encoder. Voltage: 208-240 VAC, 480 VAC, 575VAC. Motor 2HP, 3ph, 60Hz. Protection degree NEMA 4.
Optional egress safety systems	Patented Emergency Egress Systems or battery backup available. Limited to 208/1/60 or single phase.

Increased wind resistance



Side Guide and lateral driving belt

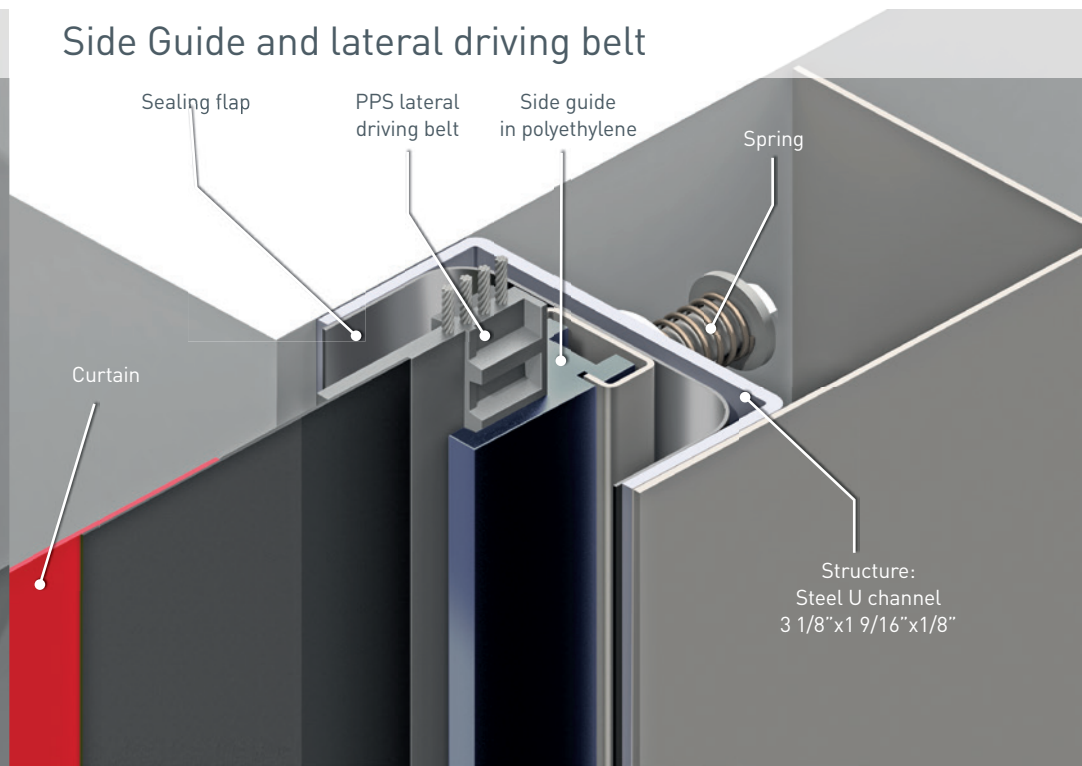

Dimensions and installation requirements DYNACO D-501 HIGH PERFORMANCE DOOR

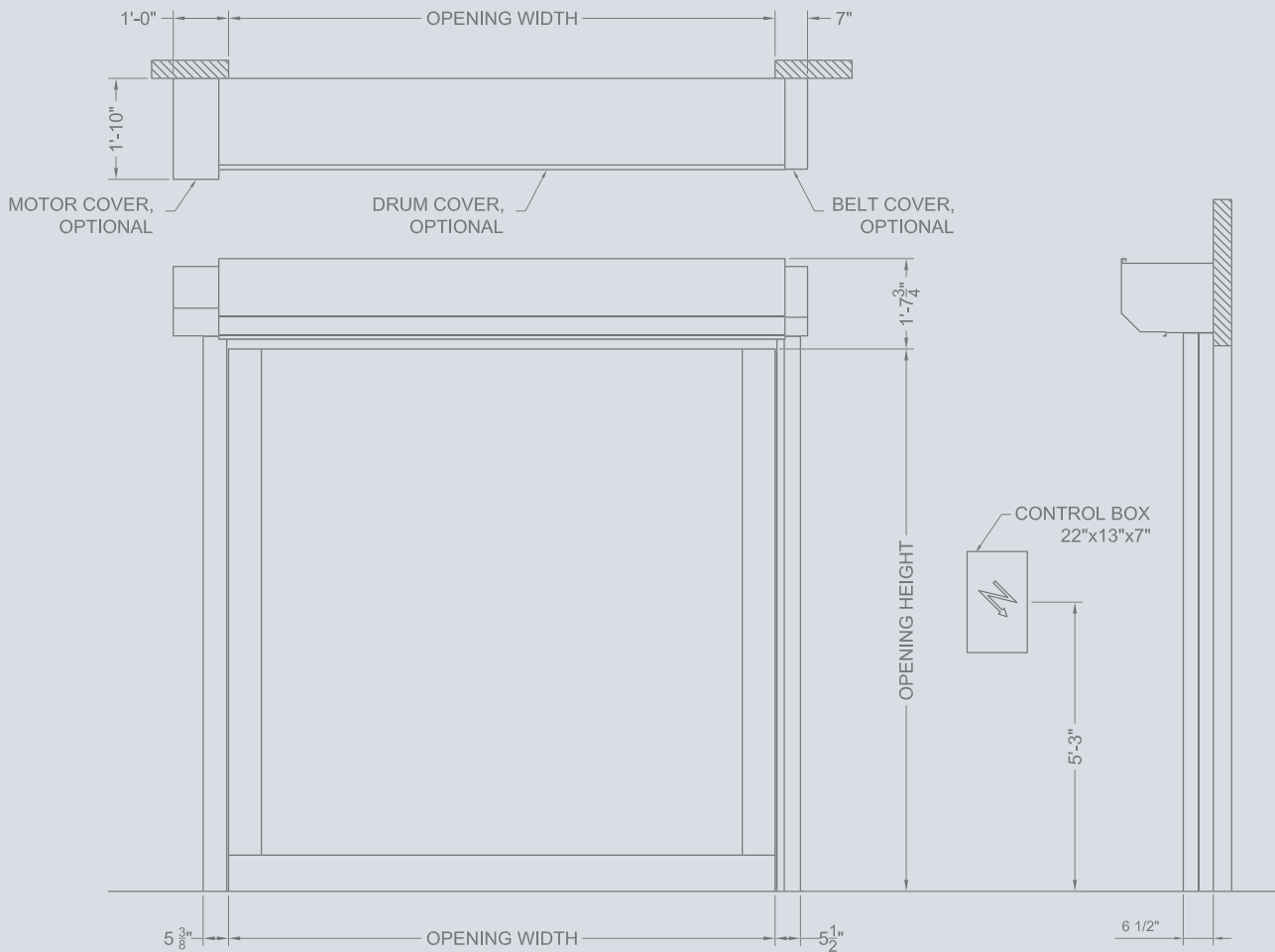

All indicated dimensions are minimum space requirements for installed door.
Note: Based upon individual environmental safety considerations,
extra safety components such as push buttons, detectors and covers may be required.

Entrematic offers a comprehensive range of products for industrial, commercial, institutional and residential applications, including sectional doors, loading dock equipment, high-performance doors, residential garage doors, pedestrian door automation and openers. Built on nearly 200 years of accumulated expertise, Entrematic is the preferred partner of distributors and the number one choice of end user customers, providing innovative products, technical expertise and a portfolio of industry-leading brands including Amarr, Kelley, Serco, Dynaco and Ditec. Entrematic, Amarr, Kelly, Serco, Normstahl, Dynaco, Ditec and EM, as words and logotypes, are examples of trademarks owned by Entrematic Group AB or companies within the Entrematic Group.

© Entrematic Group AB, 2015

The Dynaco products are protected by worldwide registered patents. As part of its policy of continuous product development, Entrematic reserves the right to change the characteristics of its products or components without prior notice. Disclaimers: For a correct use of our products, please refer to our manual. Everything that is mentioned in this brochure is only valid under the terms of use in the user manual and on condition that the door was properly installed and maintained and has not undergone abuse nor neglect.

ENTREMATICA USA
935 Campus Drive Mundelein IL 60060
P: 1-800-459-1930
P: 1-847-562-4910
F: 1-800-459-1960
Email: dynaco@dynacodoor.us
www.dynacodoor.us

ENTREMATICA