



***Built strong for the
challenges of a
busy loading dock***

**The HD Series LED Dock Light can
outlast 25 incandescent bulbs while
using up to 94% less energy.**

Dependable Performance in All Environments

The HD (Heavy-Duty) Series LED Dock Light is designed to perform efficiently in the most demanding loading dock environments, such as extreme temperatures and wet or damp conditions. Rated NEMA4 and IP66.

Customized to Suit Any Application

Available as a complete dock light (with arm and light head) or just as the light head, the HD Series comes in a wide range of configurations, such as single or double arm, swing or flex, and as a fan / light combo.

Rugged and Compact Housing

The light head's polycarbonate housing resists impact damage from forklifts or incoming trailers, lowering maintenance costs and minimizing the risk of downtime or interruptions in the cargo handling process.

Continuous Quality Light

The HD Series LED light's intensity exceeds a 300-watt incandescent bulb, but uses only 18 watts to emit a cool white light. The constant-current IP66 LED driver is rated for 100,000 hours of operation at 77° F.

HD Series LED Dock Light

HD Series LED Dock Light

BLUE GIANT[®]
AFTERMARKET SOLUTIONS

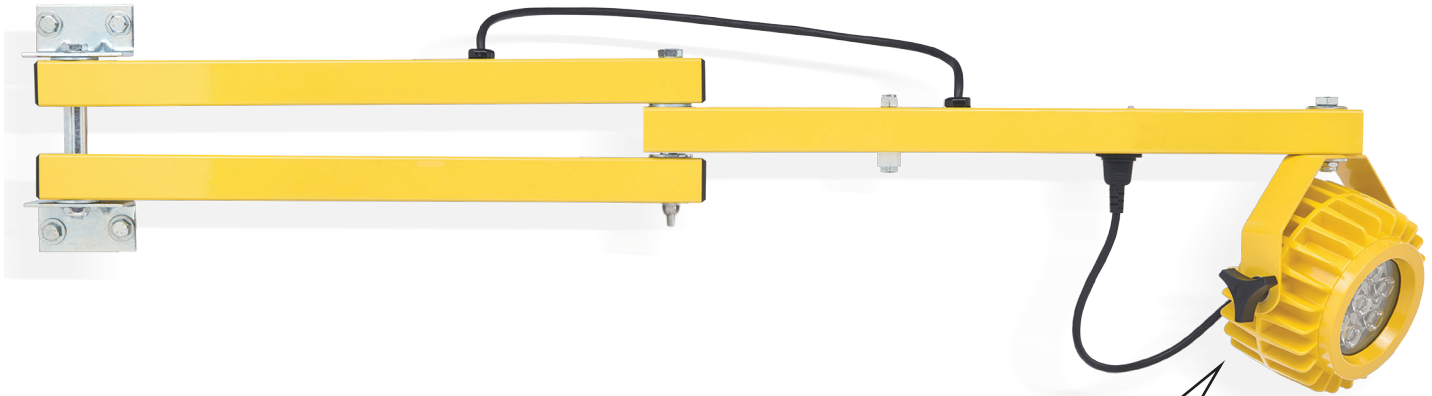

Features

- Operating temperature -20° F – 105° F
- Available as a complete dock light with arm and light head or just as a light head
- Ideal for use in food warehouses
- Rugged cast aluminum housing
- Voltage input: 100-240 VAC, 50/60 Hz, Single Phase
- UL, cUL, CE certified and RoHs compliant

The heavy-duty on / off switch are located on the recessed back plate, reducing the likelihood of impact damage from incoming trucks or warehouse vehicles and ensuring uninterrupted performance.

24" part number: DL24-HDLED
60" part number: DL60-HDLED

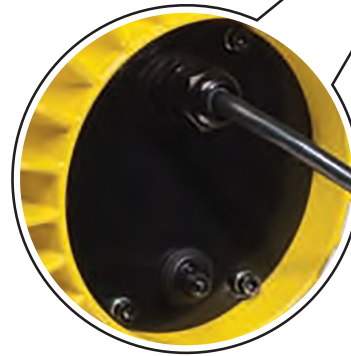

Dimensions

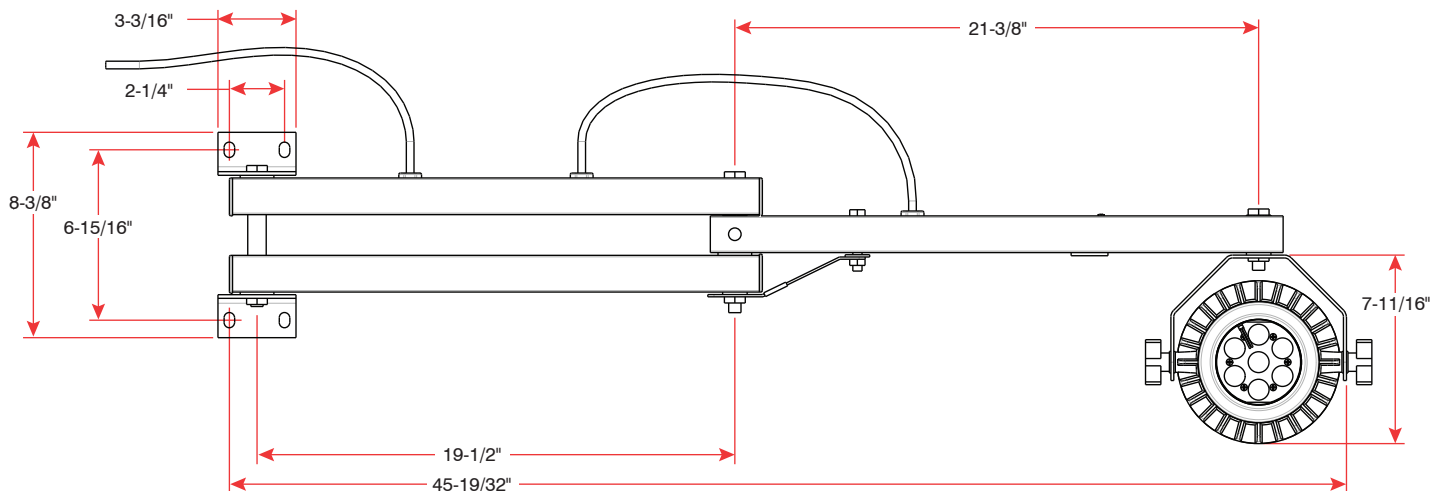

BLUE GIANT[®]
BLUE GIANT EQUIPMENT CORPORATION

Corporate 85 Heart Lake Road South
Brampton, ON, Canada L6W 3K2
t 905.457.3900 f 905.450.6555

USA 6350 Burnt Poplar Road
Greensboro, NC 27409
www.BlueGiant.com

AUTHORIZED DEALER

Blue Giant offers a full line of dock levelers, dock safety equipment, seals and shelters, accessories, ergonomic and scissor lift equipment and industrial trucks. Concurrent with our continuing product improvement program, specifications are subject to change without notice. Please contact Blue Giant for latest information. Some features illustrated may be optional in certain market areas.