

THE PERFECT SOLUTION

///ATMOSEAL®



UNIQUE DESIGN
PROVIDES
EXCELLENT SEAL

FULLY
AUTOMATED
SYSTEM
AVAILABLE

LONG-LASTING
HIGH QUALITY
VINYL WITH
U.V STABILIZER
TO PREVENT
FADING
AND CRACKING

ONE PIECE
UNITIZED
CONSTRUCTION
FOR EASY
INSTALLATIONS

"RIP STOP" FABRIC
PROVIDES
GREATER
RESISTANCE TO
WEAR AND TEAR

CUSTOM
UNITS
AVAILABLE

SERIES F14/F18/F22 **FIXED HEADER INFLATABLE DOCK SEAL**

Designed for door openings up to 8' wide X 8' high where vehicles are of a generally standard size. Since the trailer is spotted before the seal is inflated, the series F14/F18/F22 Inflatable Dock Seal is the ideal solution to eliminate potential damage to the structure of a building wall. The unique sealing process seals effectively and completely even if the trailer is off center, jack knifed or on a sloped approach. Super Seal's exclusive "Rip Stop" fabric developed specifically for inflatable products will give years of trouble free service. The series F14/F18/F22 creates an optimum seal that blocks out foul weather, insects, dust and dirt, while saving money on energy costs. Inflatable dock door seals help productivity by increasing safety, protecting personnel, products and equipment.

SUPER SEAL

Tel: 905.850.2929 Tel: 1.800.337.3239
Fax: 905.850.2922 Fax: 905.850.4440

www.supersealmfg.com

SuperSeal Mfg. Ltd.
670 Rowntree Dairy Rd.,
Woodbridge, Ontario, Canada L4L 5T8

SPECIFICATIONS

Series F14/F18/F22 Product Details:

- Series F14/F18/F22 standard dimensions for door openings 8' W x 8' H are 9'8" high (O.D.) with a 14", 18" or 22" projection, and a 12" wide face across the air bags when inflated. Deflate mode dimensions are, 9'4"W x 8'8"H (O.D.).
- Seals trailers 12' to 13' high from grade with a dock height of 48".
- Exclusive 16 oz. vinyl "RipStop" fabric developed specifically for inflatable units gives years of trouble free service. (See Material Selection Guide)
- Can be part of a totally automated dock loading system.
- One piece unitized construction air bag for ease of installation
- F-14 designed for standard 5" bumper projection.

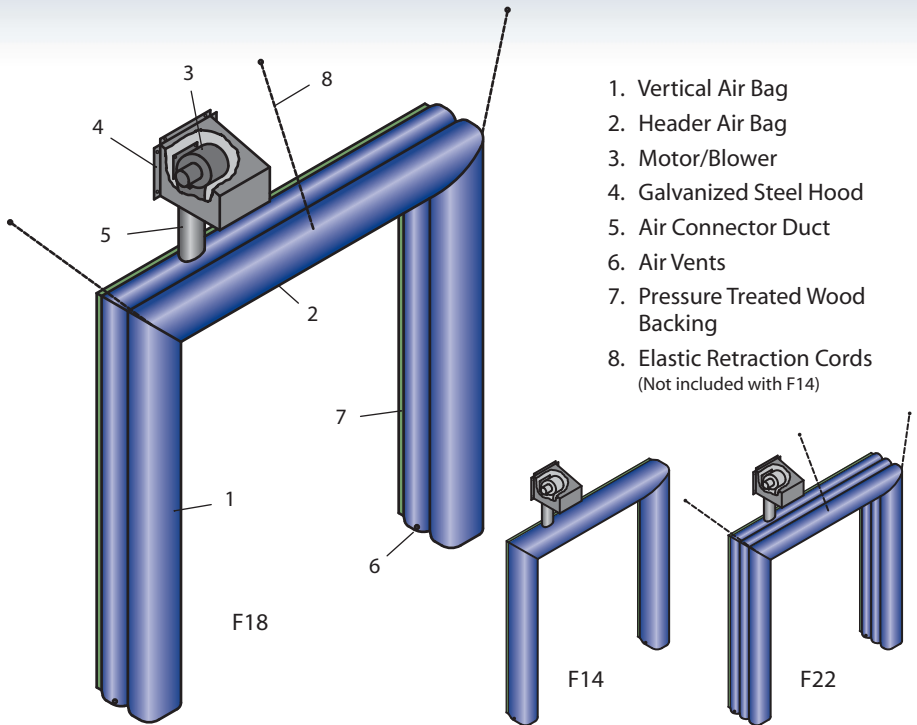

1. Vertical Air Bag
2. Header Air Bag
3. Motor/Blower
4. Galvanized Steel Hood
5. Air Connector Duct
6. Air Vents
7. Pressure Treated Wood Backing
8. Elastic Retraction Cords
(Not included with F14)

Specifications:

Fixed inflatable dock door seal(s) to be Series F14/F18/F22 as manufactured by Super Seal Mfg. Ltd., Woodbridge, Ontario. Fixed inflatable dock door seal(s) to be manufactured to fit door opening size(s) ___ft. wide X ___ft. high. Air bag unit to be one (1) piece unitized construction consisting of two (2) verticals and one (1) header member. The air bag is to be fastened onto a 2" X 8" pressure treated wood frame, (supplied unassembled by manufacturer) through brass plated grommets using galvanized wood screws. Verticals to have a slight upward taper from back to front to avoid pinching or sagging when deflated. The bottom of the vertical seals to include holes for venting of air and to assist in moisture drainage. Each unit includes an externally mounted 1/12 HP motor/blower combinations complete with a manual ON/OFF switch and a galvanized steel protective hood. Unit is inflated by turning switch on and deflates automatically when the motor/blower is turned off. Units with projections over 14" come with a series of elastic shock cords and "D" rings to assist in retraction. Unit to be manufactured of exclusive 16 oz. vinyl "RipStop" fabric. Double stitched, high strength twisted 4 ply 100% polyester bonded thread UV treated used for sewing throughout. Unit shall be furnished with all necessary mounting hardware, galvanized to resist corrosion.

Options:

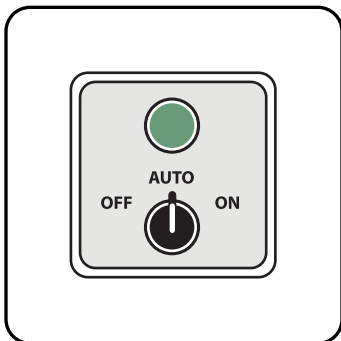

A. Automatic Switch Kit

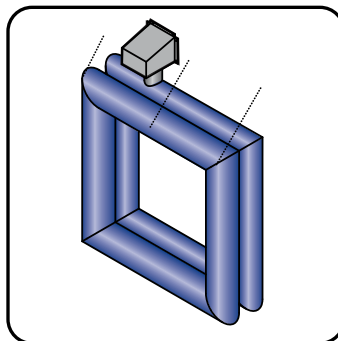

B. Four Sided Unit

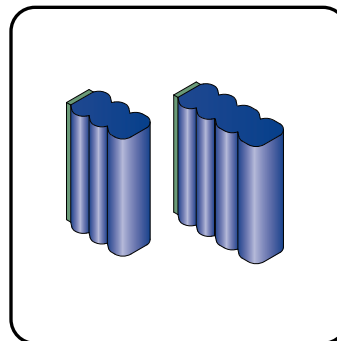

C. Extended Projection

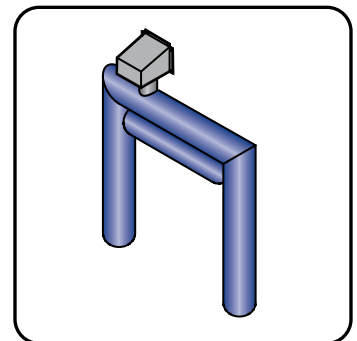

D. High Header Air Bag



DEALER IMPRINT



** All Super Seal products are subject to design modifications without notice. Product may be shown with non-standard options.