

THE PERFECT SOLUTION

ATMOSEAL®

FRAME IS MADE
OF GALVANIZED
STEEL CHANNEL
AND
PRESSURE
TREATED WOOD

QUICK AND EASY
INSTALLATION

CUSTOMER UNITS
AVAILABLE



FLEXIBLE
AND
RETRACTABLE

HIGH
PERFORMANCE
VINYL

LONG LASTING
AND
LOW MAINTANANCE

SERIES 0601 RETRACTABLE RAIL SHELTER

Designed for door openings up to 10'W x 10'H, the Series 0601 is designed to provide an air-tight passage way from the loading dock to the railcar doors. When the spring-loaded shelter is released it automatically extends and seals itself against the railcar. When not in use the Series 0601 rail shelter is manually retracted up against the building wall protected from moving railcars and wind. The Series 0601 creates a tight seal that blocks out foul weather, insects, dust and dirt, while saving money on energy costs. A large selection of tough abrasion resistant fabrics makes this unit an excellent long lasting investment. Rail shelters help productivity by increasing safety, protecting personnel, products and equipment.

SUPER SEAL

Tel: 905.850.2929 Tel: 1.800.337.3239
Fax: 905.850.2922 Fax: 905.850.4440

www.supersealmfg.com

SuperSeal Mfg. Ltd.
670 Rowntree Dairy Rd.,
Woodbridge, Ontario, Canada L4L 5T8

SPECIFICATIONS

Series 0601 Product Details:

- Series 0601 3 sided unit standard dimensions for door openings up to 10'W x 10'H are 11'W x 11'H back sloped to 10'6" front (O.D.) x 48" projection with 12" drop head curtain.
- A large selection of cover fabrics available including our exclusive SS-90 High performance vinyl. (See Material Selection Guide)
- Can be designed to suit a large variety of oversized door openings heights, widths and/or dock projections.
- Rail Shelter projection determined by measuring from inside first rail to building wall less 24"(2').

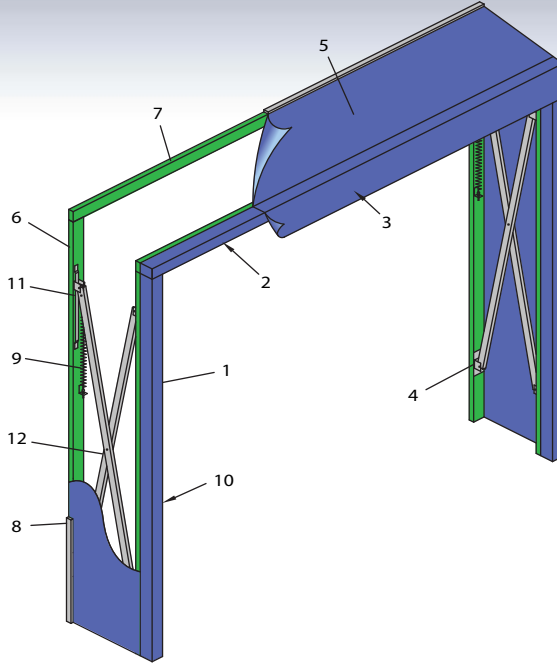

1. Vertical Pad
2. Head Pad
3. Head Curtain
4. "U" bracket
5. Projection Fabric
6. 2"x4" Vertical Pressure Treated Wood Frame
7. 2"x4" Header Pressure Treated Wood Frame
8. Finish Trim
9. Spring
10. Cover Fabric
11. Sliding Bracket
12. Scissor Extension arms

Specifications:

Retractable rail dock shelter(s) to be SERIES 0601 as manufactured by Super Seal Mfg. Ltd., Woodbridge, Ontario. Retractable rail dock shelter(s) to be manufactured to fit door opening size(s) ___ft. wide x ___ft. High. Mounting backboard frame to be constructed of top grade pressure treated wood. All steel components to be galvanized to resist corrosion. Unit to extend forward automatically on independent spring loaded galvanized steel scissor arms when released from building wall and shall maintain a constant pressure against the railcar. Unit is retracted manually by means of 2 pull chains. Fabric covered dense polyfoam vertical and head pads shall be provided at the leading edge of the shelter mounted in a formed galvanized steel channel for extra strength and rigidity. The vertical and head pad shall be constructed to give a weather tight seal against the railcar. Double stitched, high strength twisted 4 ply 100% polyester bonded thread U.V. treated used for sewing throughout. Unit shall be furnished with all necessary mounting hardware, galvanized to resist corrosion.

Options:

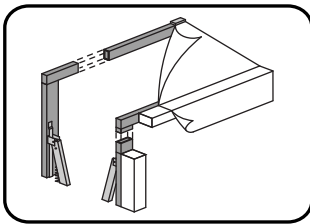

A. Tubular Steel Frame

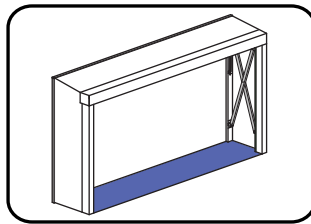

B. Four Sided Units

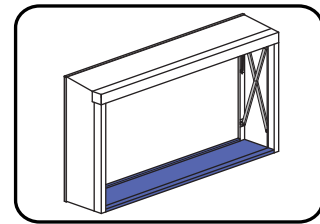

C. Four Sided Units With Foam Pad

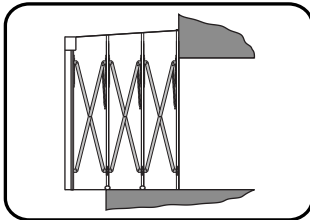

D. Extended Projection

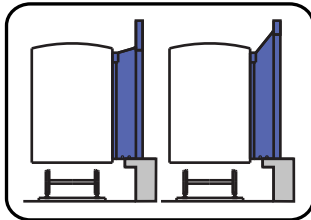

E. Higher Units

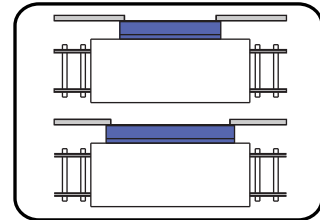

F. Wider Units

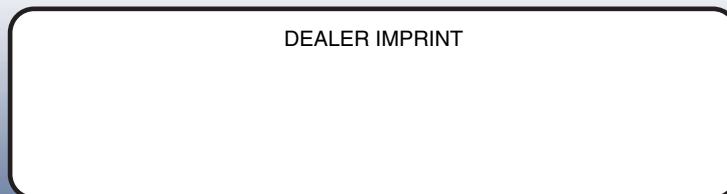

** All Super Seal products are subject to design modifications without notice. Product may be shown with non-standard options.